

REV.	DATE	ECR NO.	DESCRIPTION
A	07/21/98	-	REDIMENSION AND ADD NOTES
B	05/19/03	-	UPDATE DRAWING FORMAT
C	02/10/04	-	MODIFY PLATING SPECS
D	09/30/05	-	REVISE ALL PLATING TO BRT. TIN
E	11/14/05	-	UPDATE COMPONENT DIMENSIONS
F	12/09/08	100063	REVISE PLATING TO NICKEL

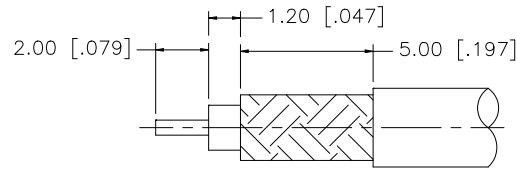

RECOMMENDED
CABLE STRIPPING DIM'S

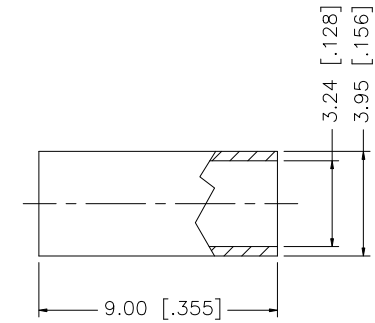
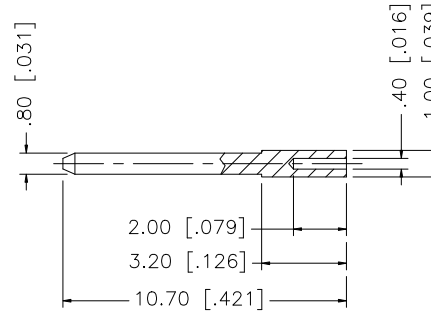
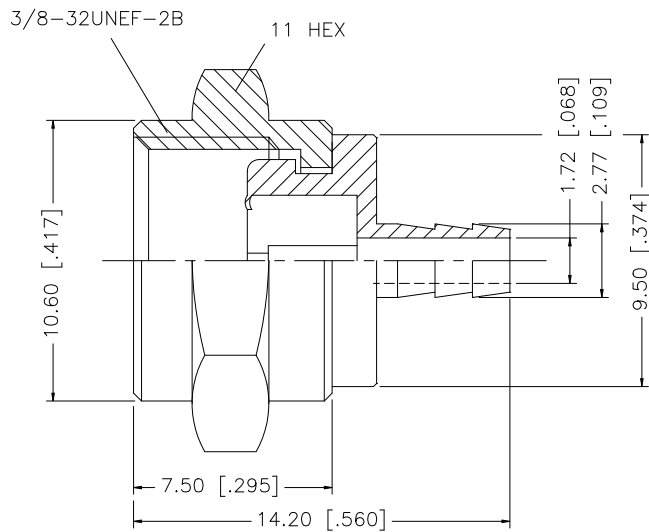

NOTE:
1. CRIMPED FERRULE HEX CRIMP SIZE .128" [3.25]

				UNLESS OTHERWISE SPECIFIED DIMENSIONS ARE IN MILLIMETERS. DIMENSIONS IN [] ARE IN INCHES AND FOR CUSTOMER REFERENCE ONLY.	APPROVALS	DATE	<h1 style="text-align: center;">Amphenol Connex</h1>				
8					DRAWN	GRS					12/09/08
7					CHECKED			PART NO. 222113			
6					ISSUED						
5	FERRULE	COPPER	NICKEL	1	SHEET	1 OF 1		REV. F SIZE A SCALE NA			
4	RING	BRASS	NICKEL	1							
3	CONTACT PIN	BRASS	GOLD	1				DO NOT SCALE DRAWING			
2	DIELECTRIC	PTFE	NATURAL	1							
1	BODY	BRASS	NICKEL	1							
DESCRIPTION				MATERIAL	FINISH	QTY					

UNLESS OTHERWISE SPECIFIED DIMENSIONS ARE IN MILLIMETERS. DIMENSIONS IN [] ARE IN INCHES AND FOR CUSTOMER REFERENCE ONLY.

UNLESS OTHERWISE SPECIFIED TOLERANCES FOR MILLIMETERS ARE:
 0.5 - 8mm ± 0.20mm
 8 - 30mm ± 0.40mm
 30 - 120mm ± 0.50mm

UNLESS OTHERWISE SPECIFIED TOLERANCES FOR INCHES ARE:
 .020 - .315 ± 0.007"
 .315 - 1.180 ± 0.015"
 1.180 - 4.724 ± 0.020"

APPROVALS	DATE
DRAWN GRS	12/09/08
CHECKED	
ISSUED	
SHEET 1 OF 1	
CAD FILE	
C:/222/222113.DWG	

Amphenol Connex

PART DESCRIPTION			
F CRIMP PLUG (RG-179/U CABLE - 75ohm)			
PART NO.			
222113			
DWG. NO.	REV.	SIZE	SCALE
222113.DWG	F	A	NA