

REV.	DATE	DESCRIPTION
NC	07/31/96	INITIAL RELEASE
A	11/16/05	UPDATE DRAWING FORMAT

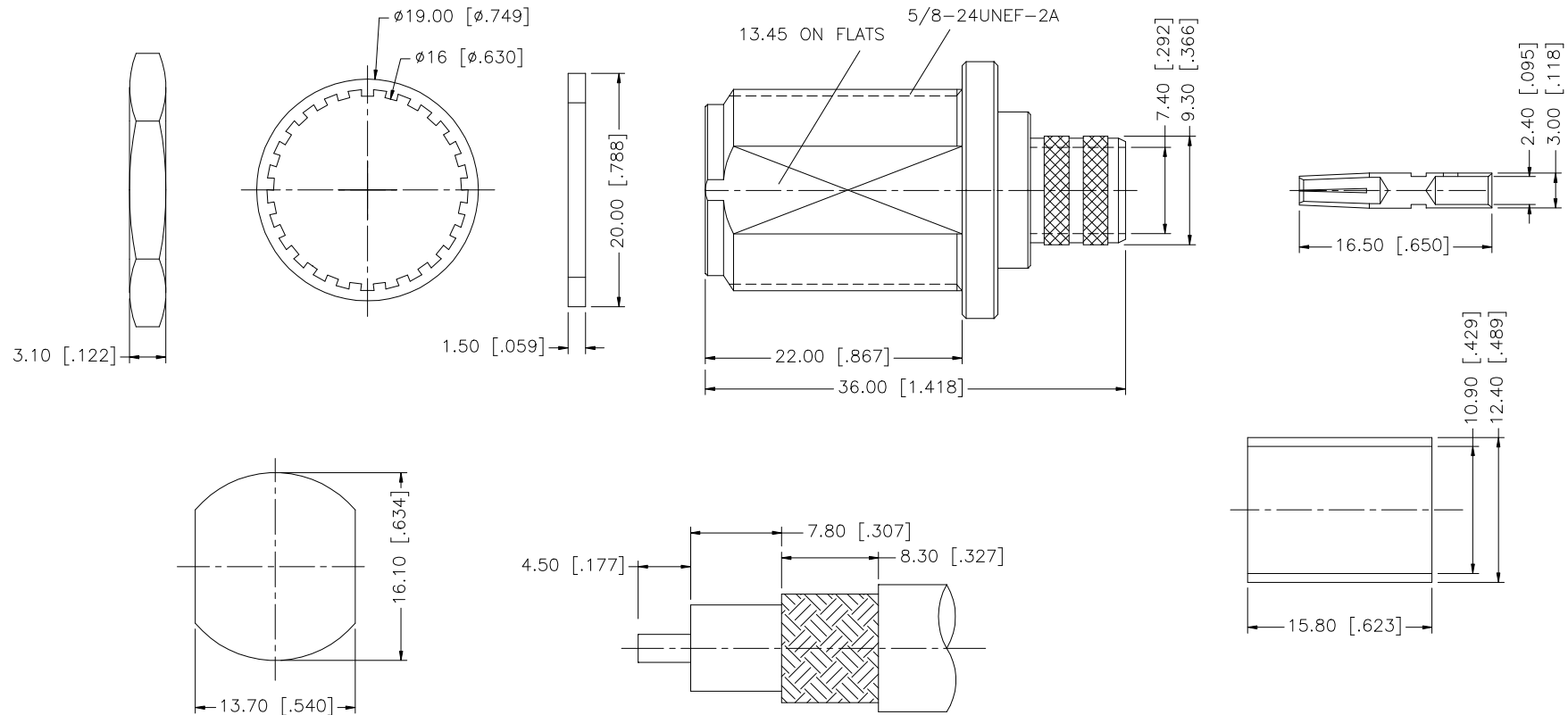

RECOMMENDED MOUNTING HOLE

RECOMMENDED CABLE STRIPPING DIMS.

NOTE:

1. CRIMPED FERRULE
HEX CRIMP SIZE .429"
2. HEX CRIMP SIZE .100"

QTY	DESCRIPTION	MATERIAL	FINISH	QTY	DO NOT SCALE DRAWING	CAD FILE	DWG. NO.	REV.	SIZE	SCALE		
8	FERRULE	COPPER	NEXCOTE	1	UNLESS OTHERWISE SPECIFIED DIMENSIONS ARE IN MILLIMETERS. DIMENSIONS IN [] ARE IN INCHES AND FOR CUSTOMER REFERENCE ONLY. UNLESS OTHERWISE SPECIFIED TOLERANCES FOR MILLIMETERS ARE: 0.5 - 8mm ± 0.20mm 8 - 30mm ± 0.40mm 30 - 120mm ± 0.50mm UNLESS OTHERWISE SPECIFIED TOLERANCES FOR INCHES ARE: .020 - .315 = ± 0.007" .315 - 1.180 = ± 0.015" 1.180 - 4.724 = ± 0.020"	C:/172/172108.DWG	172108.DWG	NC	A	NA		
7	CONTACT PIN	PHOS. BRONZE	GOLD	1								
6	HEX NUT	BRASS	NEXCOTE	1								
5	LOCK WASHER	BRASS	NEXCOTE	1								
4	GASKET	SILICONE	RED	1								
3	BARREL	BRASS	NEXCOTE	1								
2	INSULATOR	TEFLON	NATURAL	1								
1	BODY	BRASS	NEXCOTE	1								
					APPROVALS	DATE	<h1 style="text-align: center; color: blue;">Amphenol Connex</h1> <p style="text-align: center;">PART DESCRIPTION N BULKHEAD CRIMP JACK (FOR 8/U, 8A/U 213/U CABLE)</p> <p style="text-align: center;">PART NO. 172108</p>					
					DRAWN	G.R.S.						11/16/05
					CHECKED							
					ISSUED							
					SHEET	1 OF 1						