

REV.	DATE	ECR NO.	DESCRIPTION
A	01/30/04	-	UPDATE DRAWING FORMAT
B	03/03/09	-	REVISE NOTE 2 - HEX CRIMP TO .100"

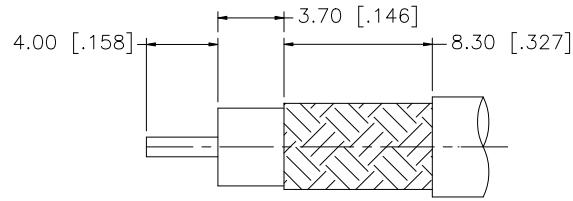

RECOMMENDED
CABLE STRIPPING DIM'S

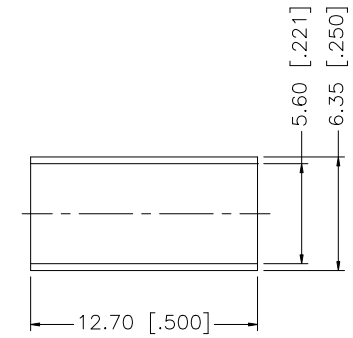
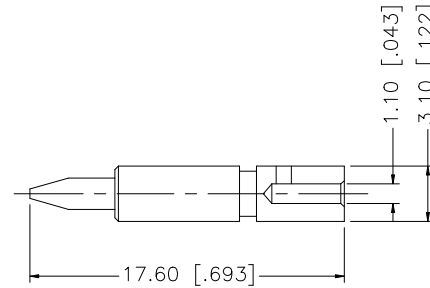
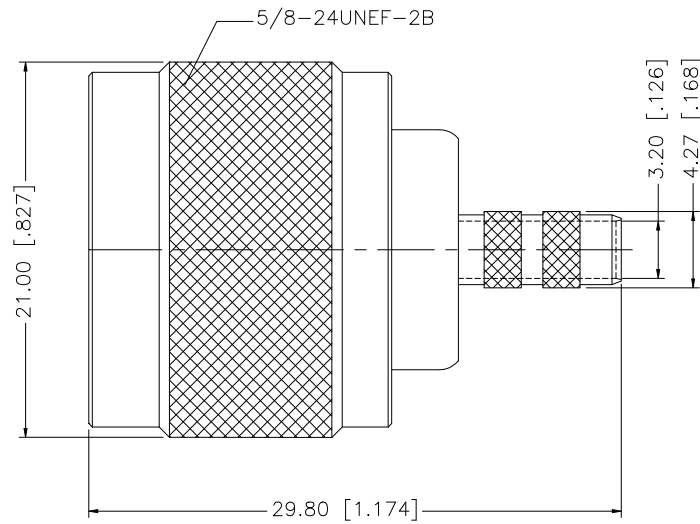

NOTES:

1. CRIMPED FERRULE HEX CRIMP SIZE .213" [5.41]
2. CRIMPED CONTACT PIN HEX CRIMP SIZE .100" [2.54]

DESCRIPTION	MATERIAL	FINISH	QTY	DO NOT SCALE DRAWING	APPROVALS	DATE	PART DESCRIPTION							
8							<h1 style="text-align: center; color: blue;">Amphenol Connex</h1> <p style="text-align: center;">N CRIMP PLUG (FOR RG-55/U, 142A/U, 223/U, 400/U)</p> <p style="text-align: center;">PART NO. 172142</p>							
7														
6														
5														
4	FERRULE	COPPER	NEXCOTE	1										
3	CONTACT PIN	BRASS	GOLD	1			DWG. NO.	172142.DWG	REV.	B	SIZE	A	SCALE	NA
2	INSULATOR	PTFE	NATURAL	1										
1	BODY	BRASS	NEXCOTE	1										
					CAD FILE	C:/172/172142.DWG								

UNLESS OTHERWISE SPECIFIED DIMENSIONS ARE IN MILLIMETERS. DIMENSIONS IN [] ARE IN INCHES AND FOR CUSTOMER REFERENCE ONLY.

UNLESS OTHERWISE SPECIFIED TOLERANCES FOR MILLIMETERS ARE:
0.5 - 8mm ± 0.20mm
8 - 30mm ± 0.40mm
30 - 120mm ± 0.50mm

UNLESS OTHERWISE SPECIFIED TOLERANCES FOR INCHES ARE:
.020 - .315 = ± 0.007"
.315 - 1.180 = ± 0.015"
1.180 - 4.724 = ± 0.020"