

RECOMMENDED  
CABLE STRIPPING DIM'S

REV.	DATE	ECR NO.	DESCRIPTION
NC	02/05/98	XXXXXX	INITIAL RELEASE
A	10/05/05	XXXXXX	INITIAL RELEASE
B	03/27/09	XXXXXX	INITIAL RELEASE
C	05/10/10	2048	CHANGE CENTER CONTACT TO STANDARD 50 OHM CONTACT

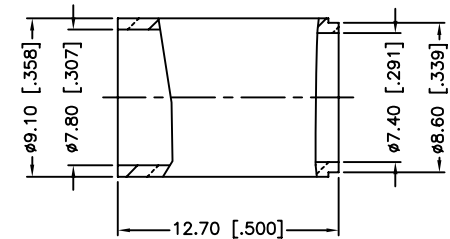
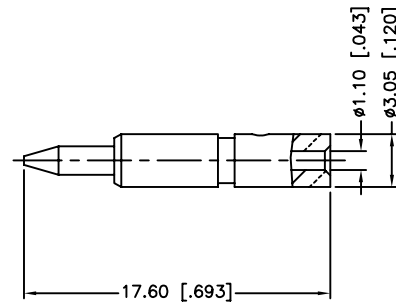
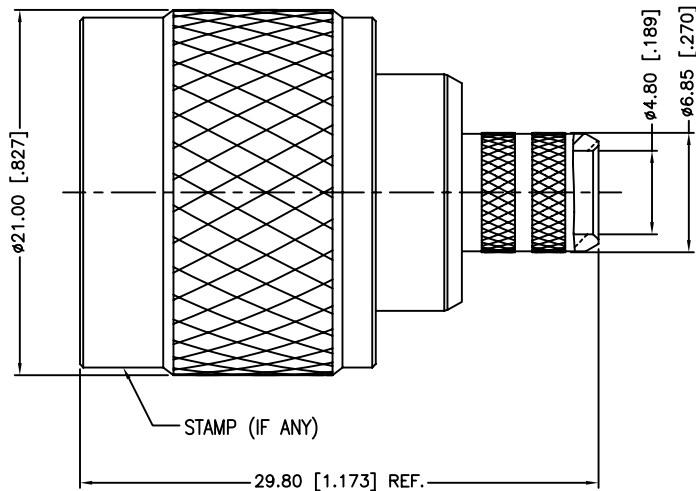

1. CRIMPED FERRULE  
HEX CRIMP SIZE .319"
2. CRIMPED CONTACT PIN  
HEX CRIMP SIZE .100"

9	FERRULE	BRASS	NEXCOTE	1
8	CONTACT PIN	BRASS	GOLD	1
7	RETAINER RING	SUS 304	NATURAL	1
6	GASKET	SILICONE	RED	1
5	CONTACT BODY	BRASS	NEXCOTE	1
4	INSULATOR	PTFE	NATURAL	1
3	BARREL	BRASS	NEXCOTE	1
2	BODY	BRASS	NEXCOTE	1
1	SHELL	BRASS	NEXCOTE	1
	DESCRIPTION	MATERIAL	FINISH	QTY

UNLESS OTHERWISE SPECIFIED DIMENSIONS ARE IN MILLIMETERS. DIMENSIONS IN [ ] ARE IN INCHES AND FOR CUSTOMER REFERENCE ONLY.

UNLESS OTHERWISE SPECIFIED TOLERANCES FOR MILLIMETERS ARE:  
0.5 - 8mm ± 0.20mm  
8 - 30mm ± 0.40mm  
30 - 120mm ± 0.50mm

UNLESS OTHERWISE SPECIFIED TOLERANCES FOR INCHES ARE:  
.020 - .315 = ± 0.007"  
.315 - 1.180 = ± 0.015"  
1.180 - 4.724 = ± 0.020"

DO NOT SCALE DRAWING

APPROVALS		DATE
DRAWN	M.ZHANG	05/10/10
CHECKED		
ISSUED		
SHEET	1 OF 1	
CAD FILE	C:/CONNEX/172202.DWG	

<b>Amphenol Connex</b>			
PART DESCRIPTION <b>N CRIMP PLUG (FOR RG-6/U CABLE)</b>			
PART NO. <b>172202</b>			
DWG. NO.	172202.DWG	REV.	C
SIZE	A	SCALE	NA