

REV.	DATE	ECR NO.	DESCRIPTION
A	01/03/04	-	UPDATE DRAWING FORMAT
B	12/03/08	-	ADD CABLE CALLOUT TO PART DESCRIPTION

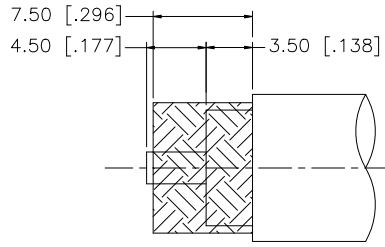

RECOMMENDED CABLE STRIPPING DIMS

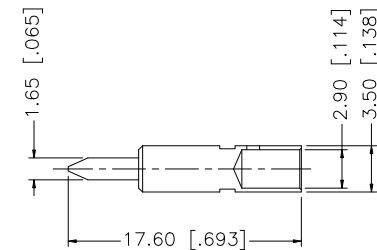
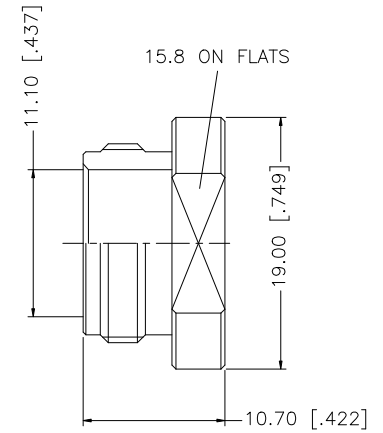
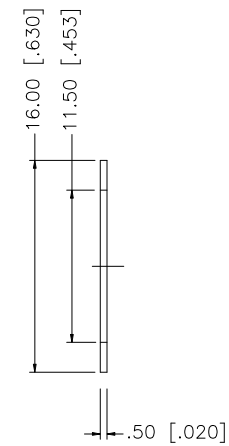
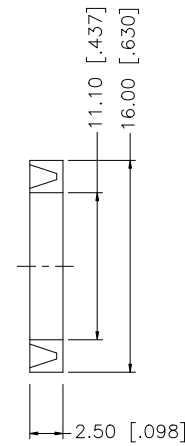
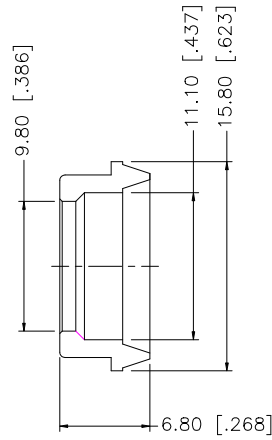
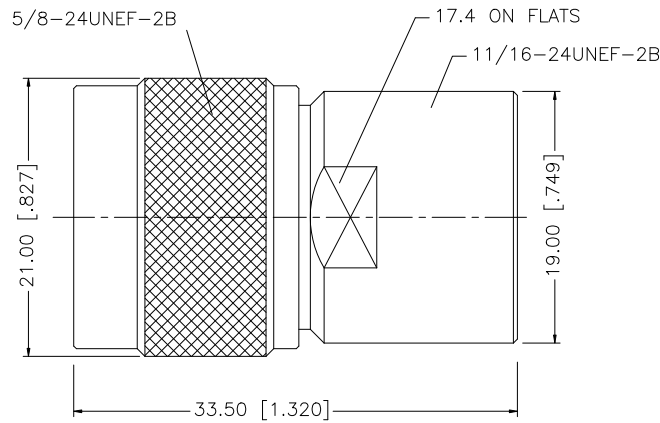

NOTE:

1. CRIMPED CONTACT PIN HEX CRIMP SIZE .118" [3.00]

QTY	DESCRIPTION	MATERIAL	FINISH	QTY
8				
7	NUT	BRASS	NEXCOTE	1
6	WASHER	BRASS	NEXCOTE	2
5	GASKET	SILICONE	RED	1
4	BRAID CLAMP	BRASS	NEXCOTE	1
3	CONTACT PIN	BRASS	GOLD	1
2	INSULATOR	PTFE	NATURAL	1
1	BODY	BRASS	NEXCOTE	1

UNLESS OTHERWISE SPECIFIED DIMENSIONS ARE IN MILLIMETERS. DIMENSIONS IN [ ] ARE IN INCHES AND FOR CUSTOMER REFERENCE ONLY.

UNLESS OTHERWISE SPECIFIED TOLERANCES FOR MILLIMETERS ARE:  
0.5 - 8mm ± 0.20mm  
8 - 30mm ± 0.40mm  
30 - 120mm ± 0.50mm

UNLESS OTHERWISE SPECIFIED TOLERANCES FOR INCHES ARE:  
.020 - .315 ± 0.007"  
.315 - 1.180 ± 0.015"  
1.180 - 4.724 ± 0.020"

DO NOT SCALE DRAWING

APPROVALS	DATE
DRAWN GRS	12/03/08
CHECKED	
ISSUED	
SHEET 1 OF 1	
CAD FILE	C:/172/172113H243.DWG

# Amphenol Connex

PART DESCRIPTION			
N CLAMP PLUG (FOR LMR400, B9913 CABLE)			
PART NO.			
172113H243			
DWG. NO.	172113H243.DWG	REV.	B
SIZE	A	SCALE	NA