

REV.	DATE	DESCRIPTION
NC	01/25/00	INITIAL RELEASE
A	02/19/07	UPDATE DRAWING FORMAT
B	06/14/07	REVISE CRIMP NOTES
C	09/03/07	REVISE CRIMP NOTES, REMOVE NOTE 2.

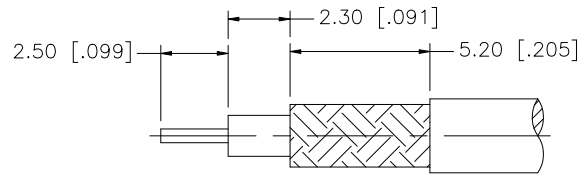

RECOMMENDED
CABLE STRIPPING DIM'S

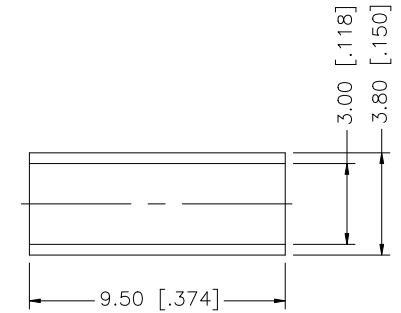
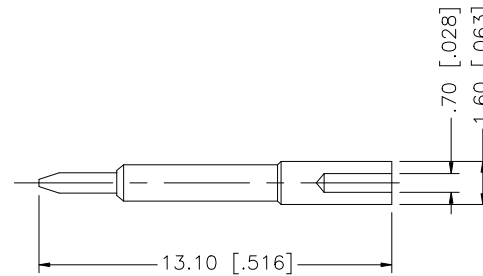
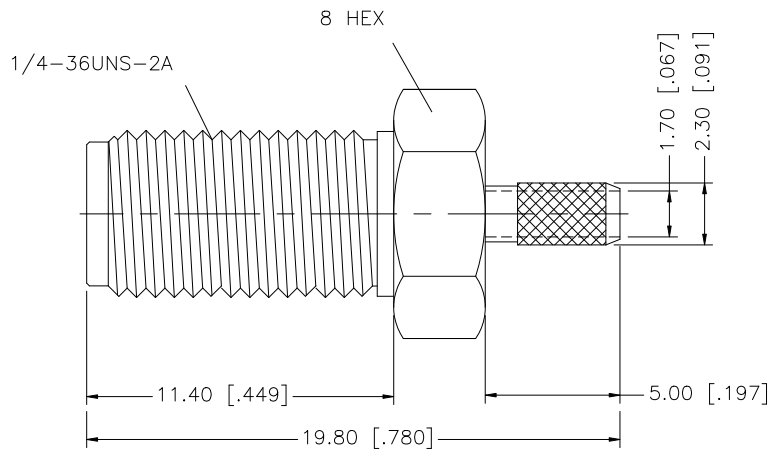

NOTE:
1. CRIMPED FERRULE HEX CRIMP SIZE .128"

8			
7			
6			
5			
4	FERRULE	BRASS	GOLD 1
3	CONTACT PIN	BRASS	GOLD 1
2	INSULATOR	TEFLON	NATURAL 1
1	BODY	BRASS	GOLD 1
DESCRIPTION	MATERIAL	FINISH	QTY

UNLESS OTHERWISE SPECIFIED DIMENSIONS ARE IN MILLIMETERS. DIMENSIONS IN [] ARE IN INCHES AND FOR CUSTOMER REFERENCE ONLY.

UNLESS OTHERWISE SPECIFIED TOLERANCES FOR MILLIMETERS ARE:
0.5 - 8mm ± 0.20mm
8 - 30mm ± 0.40mm
30 - 120mm ± 0.50mm

UNLESS OTHERWISE SPECIFIED TOLERANCES FOR INCHES ARE:
.020 - .315 = ± 0.007"
.315 - 1.180 = ± 0.015"
1.180 - 4.724 = ± 0.020"

DO NOT SCALE DRAWING

APPROVALS	DATE
DRAWN G.R.S.	09/03/07
CHECKED	
ISSUED	
SHEET 1 OF 1	
CAD FILE	C:/132/132117RP.DWG

Amphenol Connex

PART DESCRIPTION

SMA REVERSE POLARITY CRIMP JACK
(FOR RG-174/U, 188A/U, 316/U CABLE)

PART NO.

132117RP

DWG. NO.

132117RP.DWG

REV. C

SIZE A

SCALE NA