

REV.	DATE	DESCRIPTION
A	02/24/03	UPDATE DRAWING FORMAT
B	07/31/07	REVISE PART ORIENTATION

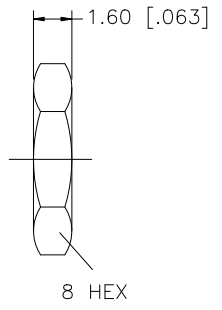
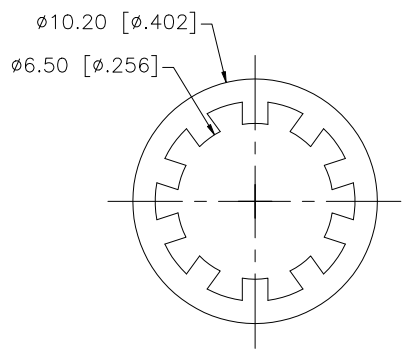
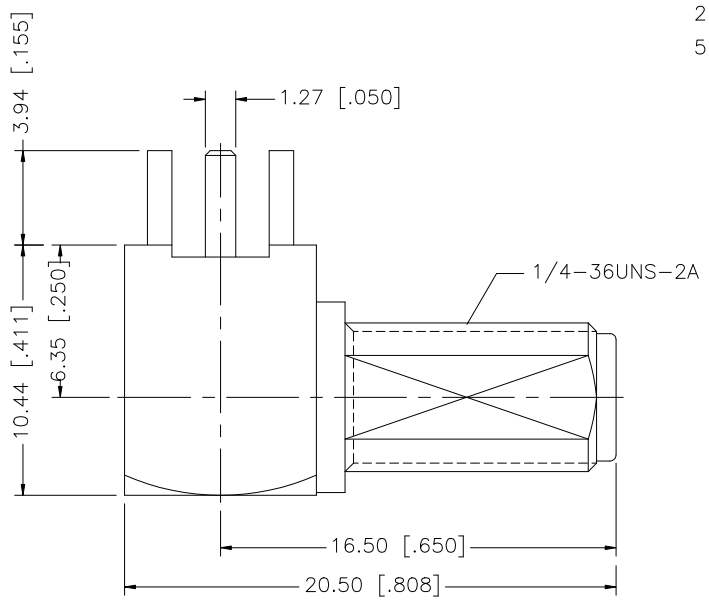
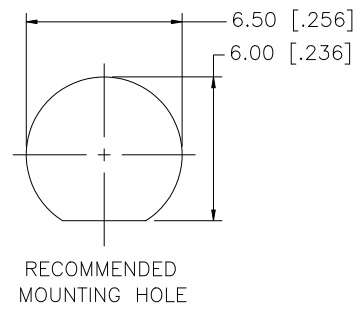
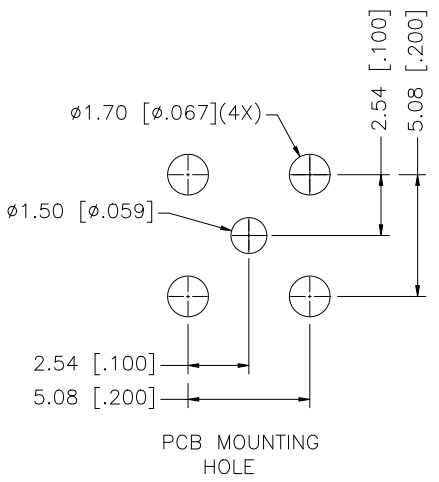
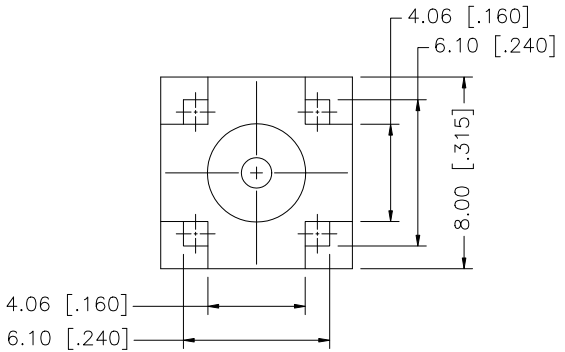

NOTE:
1. MAX. PANEL THICKNESS 2.4mm [.094]

DESCRIPTION	MATERIAL	FINISH	QTY
8			
7	HEX NUT	BRASS	GOLD 1
6	LOCK WASHER	BRASS	GOLD 1
5	CONTACT PIN	BRASS	GOLD 1
4	INSULATOR	TEFLON	NATURAL 1
3	CONTACT PIN	BRASS	GOLD 1
2	INSULATOR	TEFLON	NATURAL 1
1	HOUSING/BODY	BRASS	GOLD 1

UNLESS OTHERWISE SPECIFIED DIMENSIONS ARE IN MILLIMETERS. DIMENSIONS IN [] ARE IN INCHES AND FOR CUSTOMER REFERENCE ONLY.

UNLESS OTHERWISE SPECIFIED TOLERANCES FOR MILLIMETERS ARE:
0.5 - 8mm ± 0.20mm
8 - 30mm ± 0.40mm
30 - 120mm ± 0.50mm

UNLESS OTHERWISE SPECIFIED TOLERANCES FOR INCHES ARE:
.020 - .315 = ± 0.007"
.315 - 1.180 = ± 0.015"
1.180 - 4.724 = ± 0.020"

DO NOT SCALE DRAWING

APPROVALS	DATE
DRAWN G.R.S.	07/31/07
CHECKED	
ISSUED	
SHEET 1 OF 1	
CAD FILE	C:/132/132203RP.DWG

Amphenol Connex

PART DESCRIPTION
**SMA R/A BULKHEAD P.C. MOUNT JACK
(REVERSE POLARIZED)**

PART NO.
132203RP

DWG. NO. 132203RP.DWG REV. B SIZE A SCALE NA