

REV.	DATE	ECR NO.	DESCRIPTION
NC	07/31/98	-	INITIAL RELEASE
A	05/01/04	-	UPDATE DRAWING FORMAT
B	07/21/05	-	MODIFY MAIN BODY DIMENSION TO 17.11
C	04/09/10	2038	ADD HEX CRIMP DIMENSIONS AND SOLDER CENTER CONTACT NOTE

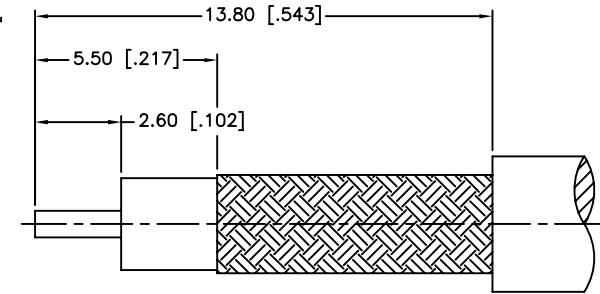
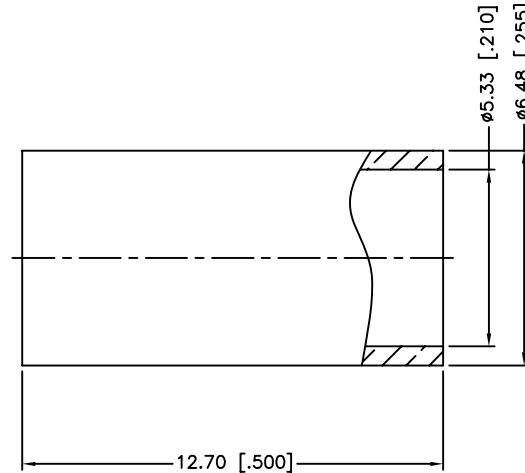
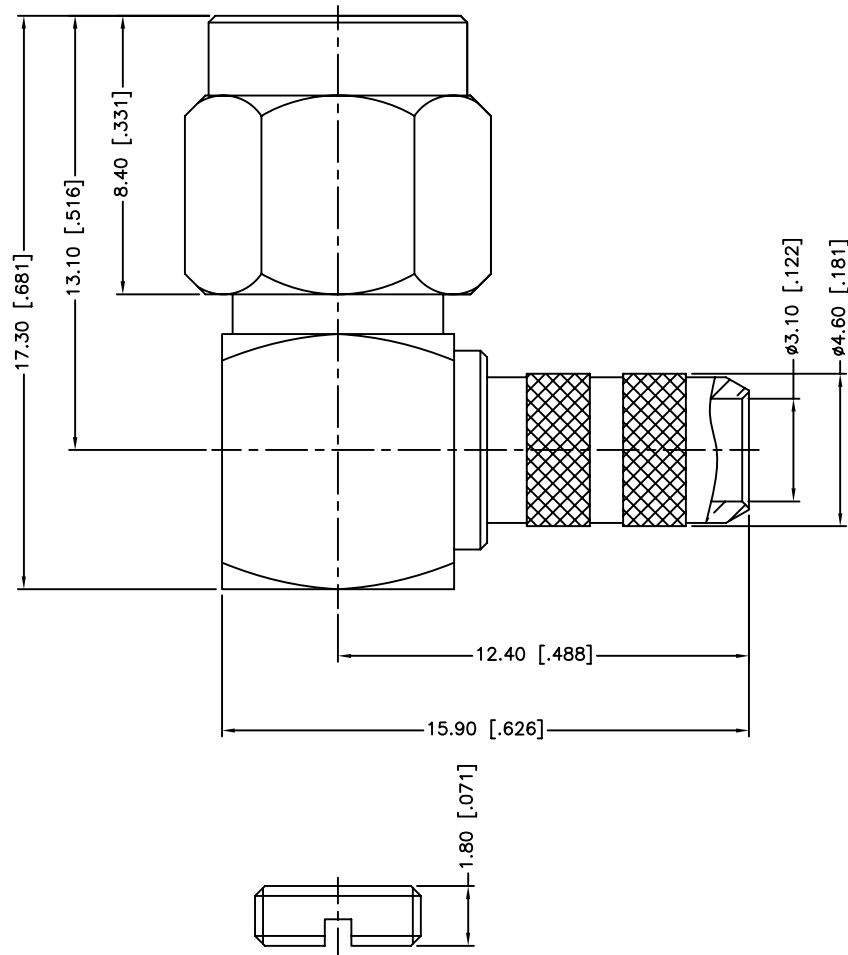

RECOMMENDED
CABLE STRIPPING DIM'S

NOTES:

1. CRIMPED FERRULE
HEX CRIMP SIZE .213"
2. CONTACT PIN TO SOLDER

DESCRIPTION	MATERIAL	FINISH	QTY
8 FERRULE	COPPER	GOLD	1
7 COVER	BRASS	GOLD	1
6 GASKET	SILICONE	RED	1
5 RETAINER RING	BERYLLIUM COPPER	NATURAL	1
4 CONTACT PIN	BERYLLIUM COPPER	GOLD	1
3 INSULATOR	PTFE	NATURAL	1
2 HOUSING WITH BARREL	BRASS	GOLD	1
1 SHELL	BRASS	GOLD	1

UNLESS OTHERWISE SPECIFIED DIMENSIONS ARE IN MILLIMETERS. DIMENSIONS IN [] ARE IN INCHES AND FOR CUSTOMER REFERENCE ONLY.
UNLESS OTHERWISE SPECIFIED TOLERANCES FOR MILLIMETERS ARE: 0.5 - 8mm \pm 0.20mm 8 - 30mm \pm 0.40mm 30 - 120mm \pm 0.50mm
UNLESS OTHERWISE SPECIFIED TOLERANCES FOR INCHES ARE: .020 - .315 = \pm 0.007" .315 - 1.180 = \pm 0.015" 1.180 - 4.724 = \pm 0.020"
DO NOT SCALE DRAWING

APPROVALS	DATE
DRAWN M.ZHANG	04/09/10
CHECKED	
ISSUED	
SHEET 1 OF 1	
CAD FILE	

Amphenol Connex			
PART DESCRIPTION SMA REVERSE POLARITY R/A CRIMP PLUG (FOR RG-58C/U, 58/U CABLE)			
PART NO. 132122RP			
DWG. NO.	132122RP.DWG	REV. C	SCALE NA