

REV.	DATE	DESCRIPTION
NC	08/03/98	INITIAL RELEASE
A	01/11/07	UPDATE DRAWING FORMAT

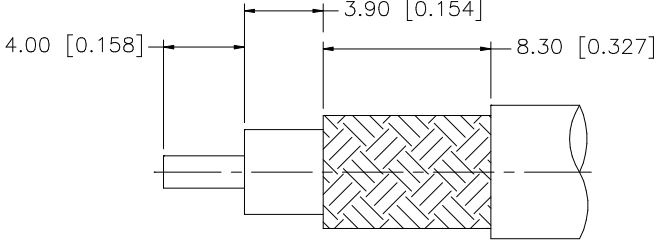

RECOMMENDED  
CABLE STRIPPING DIMS.

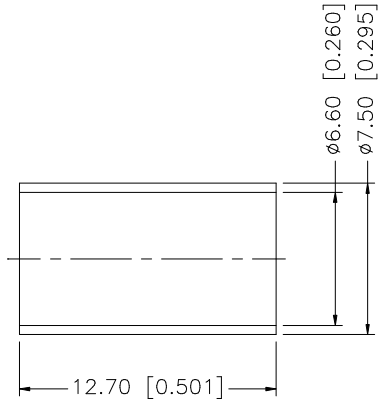
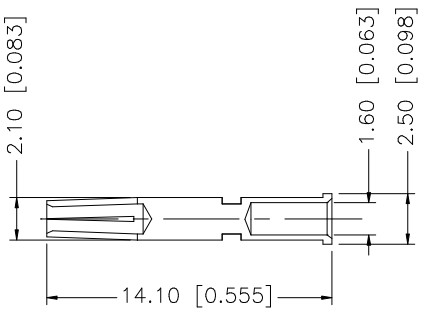
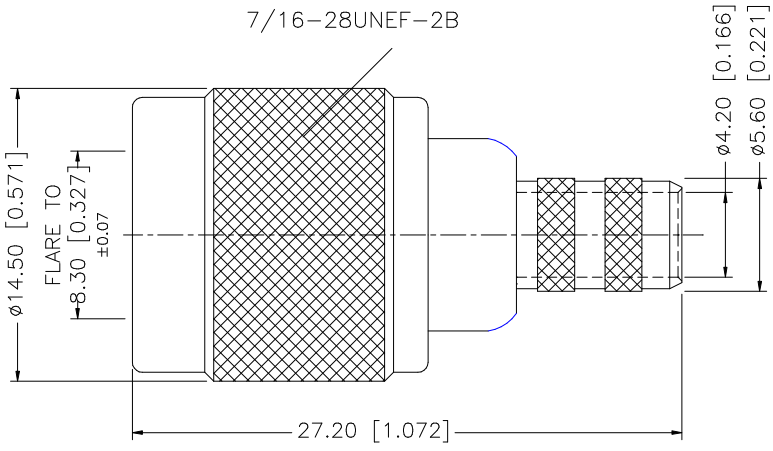

- NOTE:
1. CRIMPED FERRULE HEX CRIMP SIZE .255"
  2. CRIMPED CONTACT PIN HEX CRIMP SIZE .068"

8				
7				
6				
5				
4	FERRULE	COPPER	NICKEL	1
3	CONTACT PIN	PHOS. BRONZE	GOLD	1
2	INSULATOR	TEFLON	NATURAL	1
1	BODY	BRASS	NICKEL	1
	DESCRIPTION	MATERIAL	FINISH	QTY

UNLESS OTHERWISE SPECIFIED DIMENSIONS ARE IN MILLIMETERS. DIMENSIONS IN [ ] ARE IN INCHES AND FOR CUSTOMER REFERENCE ONLY.

UNLESS OTHERWISE SPECIFIED TOLERANCES FOR MILLIMETERS ARE:  
0.5 - 8mm ± 0.20mm  
8 - 30mm ± 0.40mm  
30 - 120mm ± 0.50mm

UNLESS OTHERWISE SPECIFIED TOLERANCES FOR INCHES ARE:  
.020 - .315 = ± 0.007"  
.315 - 1.180 = ± 0.015"  
1.180 - 4.724 = ± 0.020"

DO NOT SCALE DRAWING

APPROVALS	DATE
DRAWN G.R.S.	01/11/07
CHECKED	
ISSUED	
SHEET 1 OF 1	
CAD FILE	C:/122/122408RP.DWG

**Amphenol Connex**

PART DESCRIPTION  
**TNC REVERSE POLARITY CRIMP PLUG  
(FOR RG-8X, LMR240 CABLE)**

PART NO.  
**122408RP**

DWG. NO.	122408RP.DWG	REV.	A	SIZE	A	SCALE	NA
----------	--------------	------	---	------	---	-------	----