

REV.	DATE	ECR NO.	DESCRIPTION
A	11/26/03	XXXXXX	UPDATE DRAWING FORMAT
B	03/05/07	XXXXXX	REVISE BARREL AND FERRULE DIMENSION
C	10/28/07	XXXXXX	ADD CRIMP NOTES
D	06/18/09	XXXXXX	DIRECTION OF THE CRIMPING WAS CHANGED

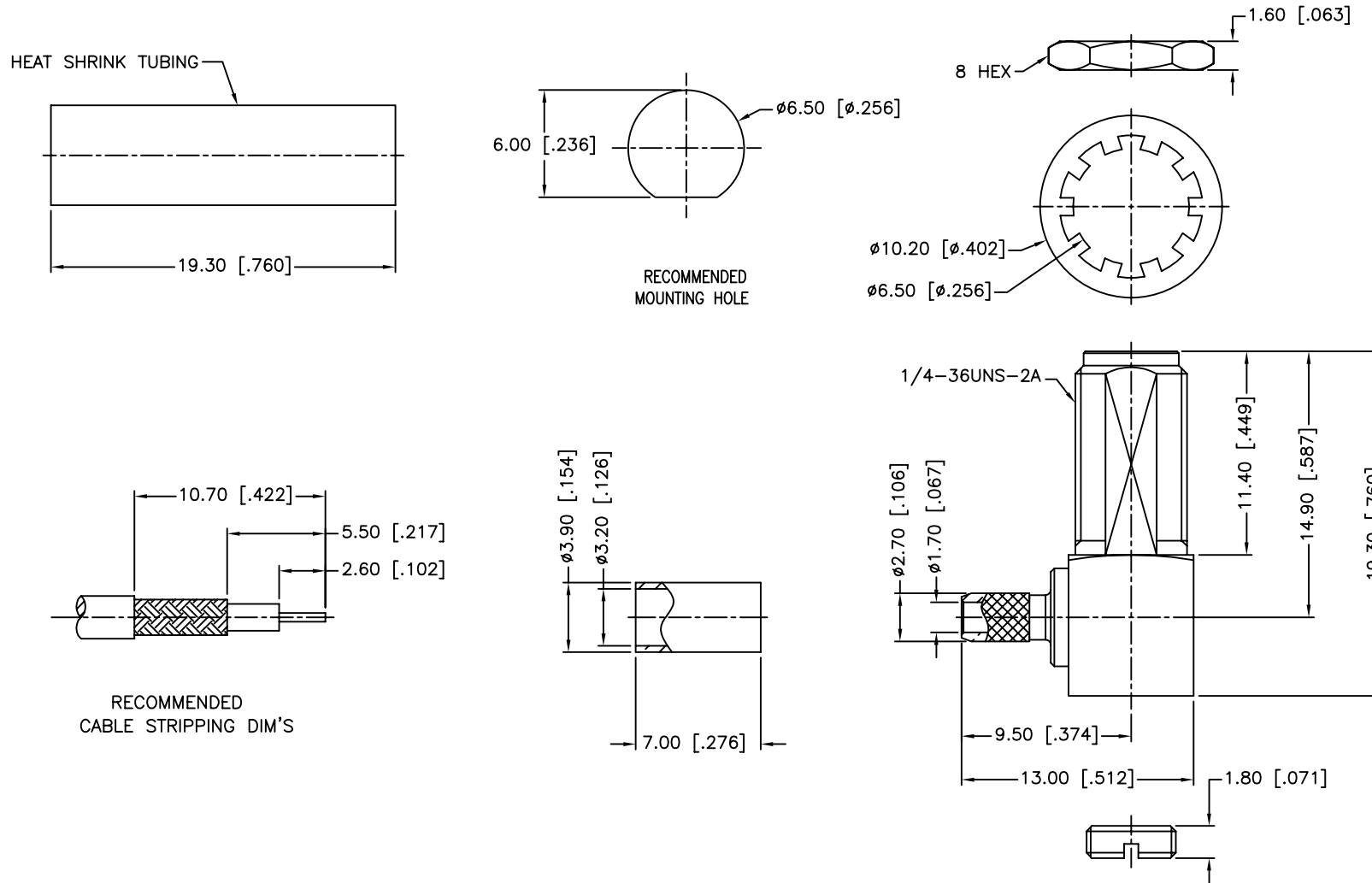

1. CRIMPED FERRULE
HEX CRIMP SIZE .128"
2. CONTACT PIN TO SOLDER
3. MAX. PANEL THICKNESS=3.2MM

8	HEAT SHRINK TUBING			1
7	FERRULE	BRASS	GOLD	1
6	COVER	BRASS	GOLD	1
5	HEX NUT	BRASS	GOLD	1
4	LOCK WASHER	BRASS	GOLD	1
3	CONTACT PIN	BER. COPPER	GOLD	1
2	INSULATOR	PTFE	NATURAL	1
1	BODY WITH BARREL	BRASS	GOLD	1
	DESCRIPTION	MATERIAL	FINISH	QTY

UNLESS OTHERWISE SPECIFIED DIMENSIONS ARE IN MILLIMETERS. DIMENSIONS IN [] ARE IN INCHES AND FOR CUSTOMER REFERENCE ONLY.

UNLESS OTHERWISE SPECIFIED TOLERANCES FOR MILLIMETERS ARE:
0.5 - 8mm ± 0.20mm
8 - 30mm ± 0.40mm
30 - 120mm ± 0.50mm

UNLESS OTHERWISE SPECIFIED TOLERANCES FOR INCHES ARE:
.020 - .315 ± 0.007"
.315 - 1.180 ± 0.015"
1.180 - 4.724 ± 0.020"

DO NOT SCALE DRAWING

APPROVALS	DATE
DRAWN M.ZHANG	06/18/09
CHECKED	
ISSUED	
SHEET 1 OF 1	
CAD FILE	C:/CONNEX/132245.DWG

Amphenol Connex

PART DESCRIPTION
**SMA R/A BULKHEAD JACK
(FOR RG-174/U,188A/U,316/U)**

PART NO.
132245

DWG. NO. 132245.DWG REV. D SIZE A SCALE NA