

REV.	DATE	ECR NO.	DESCRIPTION
NC	09/07/08	-	INITIAL RELEASE

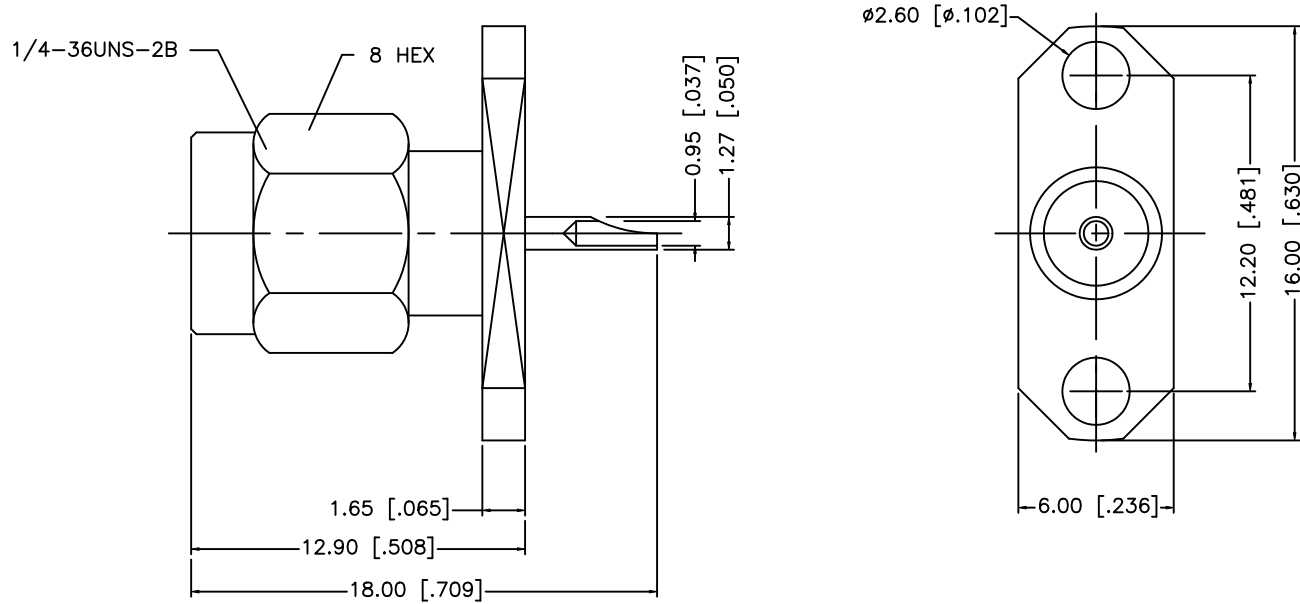

8				<small>UNLESS OTHERWISE SPECIFIED DIMENSIONS ARE IN MILLIMETERS. DIMENSIONS IN [ ] ARE IN INCHES AND FOR CUSTOMER REFERENCE ONLY.</small> <small>UNLESS OTHERWISE SPECIFIED TOLERANCES FOR MILLIMETERS ARE:</small> 0.5 - 8mm ± 0.20mm 8 - 30mm ± 0.40mm 30 - 120mm ± 0.50mm <small>UNLESS OTHERWISE SPECIFIED TOLERANCES FOR INCHES ARE:</small> .020 - .315 = ± 0.007" .315 - 1.180 = ± 0.015" 1.180 - 4.724 = ± 0.020"	APPROVALS	DATE	<h1 style="color: blue;">Amphenol Connex</h1>	
7			DRAWN		GRS	09/07/08		<b>PART DESCRIPTION</b> SMA PANEL REPECTACLE SOLDER POT CONTACT
6			CHECKED					
5			ISSUED					
4				SHEET	1 OF 1		<b>PART NO.</b> 132141	
3	CONTACT PIN	BER. COPPER	GOLD	1				
2	INSULATOR	PTFE	NATURAL	1			<b>DWG. NO.</b> 132141.DWG	
1	BODY	BRASS	GOLD	1				
	DESCRIPTION	MATERIAL	FINISH	QTY	DO NOT SCALE DRAWING	C:/132/132141.DWG	<b>REV.</b> NC <b>SIZE</b> A <b>SCALE</b> NA	