

REV.	DATE	ECR NO.	DESCRIPTION
NC	05/13/11	XXXXXX	INITIAL RELEASE

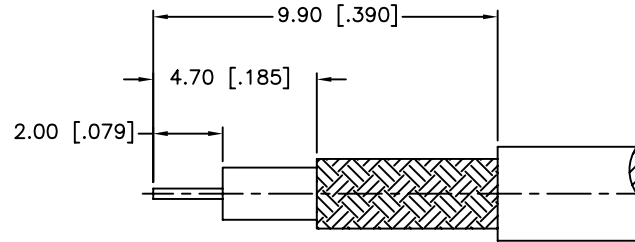
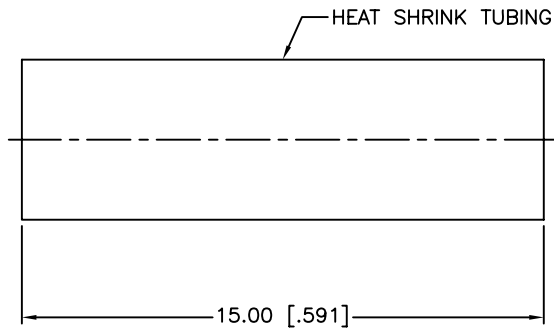
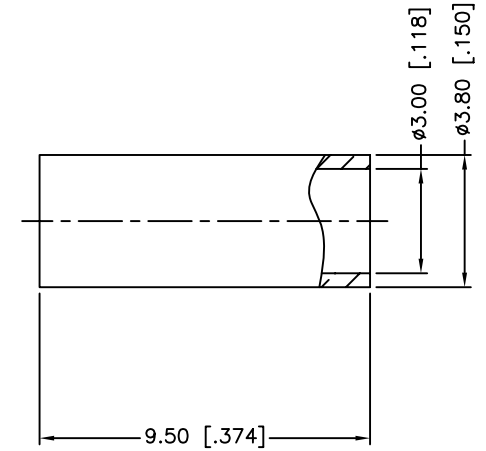
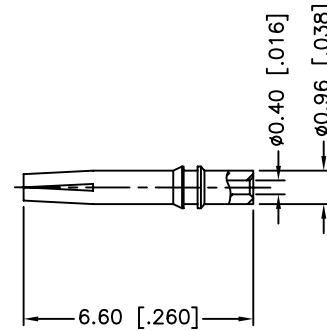
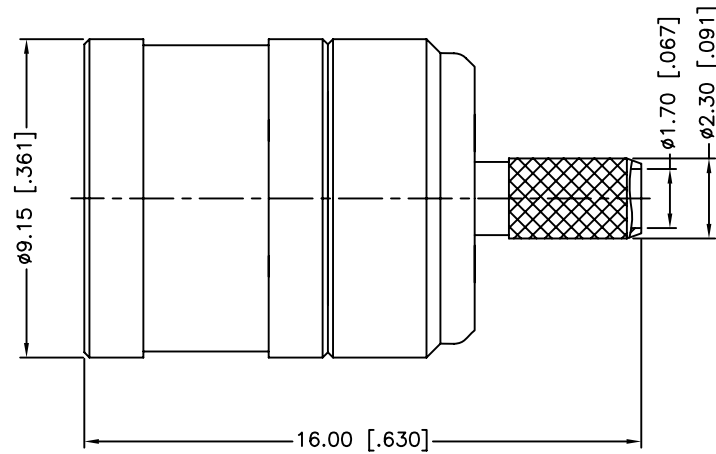

RECOMMENDED
CABLE STRIPPING DIM'S

1. CRIMPED FERRULE
HEX CRIMP SIZE .128"
2. CONTACT PIN TO SOLDER

DESCRIPTION	MATERIAL	FINISH	QTY
8 HEAT SHRINK TUBING		BLACK	1
7 FERRULE	COPPER	NICKEL	1
6 CONTACT PIN	BURYLLIUM COPPER	GOLD	1
5 SHELL	BRASS	NICKEL	1
4 RETAINER RING	BURYLLIUM COPPER	NATURAL	1
3 BARREL	BRASS	NICKEL	1
2 INSULATOR	PTFE	NATURAL	1
1 BODY	BRASS	GOLD	1

UNLESS OTHERWISE SPECIFIED DIMENSIONS ARE IN MILLIMETERS. DIMENSIONS IN [] ARE IN INCHES AND FOR CUSTOMER REFERENCE ONLY.

UNLESS OTHERWISE SPECIFIED TOLERANCES FOR MILLIMETERS ARE:
0.5 - 8mm ± 0.20mm
8 - 30mm ± 0.40mm
30 - 120mm ± 0.50mm

UNLESS OTHERWISE SPECIFIED TOLERANCES FOR INCHES ARE:
.020 - .315 = ± 0.007"
.315 - 1.180 = ± 0.015"
1.180 - 4.724 = ± 0.020"

DO NOT SCALE DRAWING

APPROVALS	DATE
DRAWN M.ZHANG	05/13/11
CHECKED	
ISSUED	
SHEET 1 OF 1	
CAD FILE C:/CONNEX/142101.DWG	

Amphenol Connex			
PART DESCRIPTION SMZ CRIMP PLUG (FOR RG-179/U, 187A/U CABLE)			
PART NO. 142101			
DWG. NO.	142101.DWG	REV.	NC
SIZE	A	SCALE	NA