

REV.	DATE	ECR NO.	DESCRIPTION
NC	03/20/05	-	INITIAL RELEASE
A	01/20/09	100073	UPDATE DRAWING FORMAT

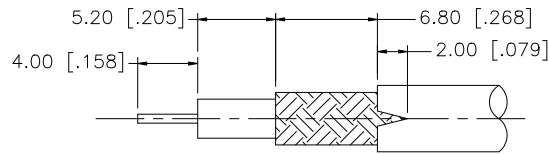

RECOMMENDED
CABLE STRIPPING DIM'S

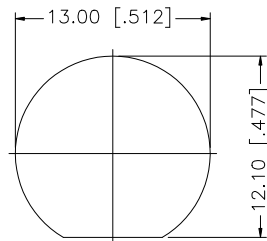
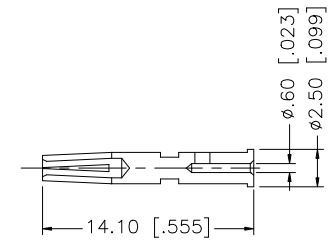
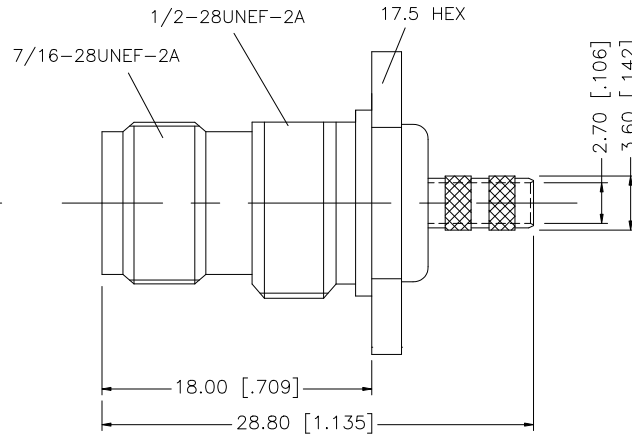
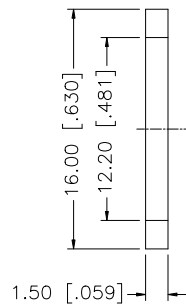
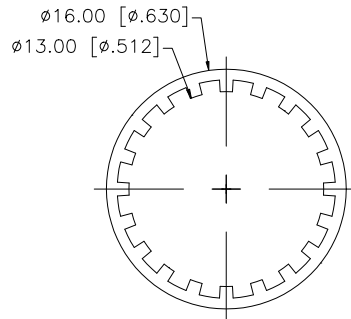
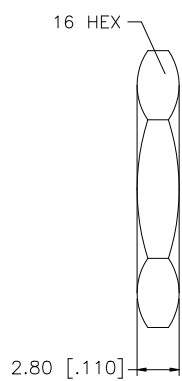

RECOMMENDED
MOUNTING HOLE

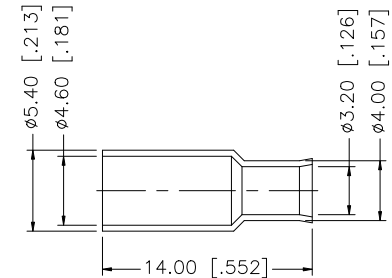
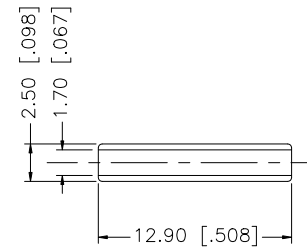

8	FERRULE	COPPER	NICKEL	1
7	SLEEVE	DELTRIN	NATURAL	1
6	HEX NUT	BRASS	NICKEL	1
5	LOCK WASHER	BRASS	NICKEL	1
4	GASKET	SILICONE	RED	1
3	CONTACT PIN	BER. COPPER	GOLD	1
2	INSULATOR	DELTRIN	NATURAL	1
1	BODY	BRASS	NICKEL	1
	DESCRIPTION	MATERIAL	FINISH	QTY

UNLESS OTHERWISE SPECIFIED DIMENSIONS ARE IN MILLIMETERS. DIMENSIONS IN [] ARE IN INCHES AND FOR CUSTOMER REFERENCE ONLY.

UNLESS OTHERWISE SPECIFIED TOLERANCES FOR MILLIMETERS ARE:
0.5 - 8mm ± 0.20mm
8 - 30mm ± 0.40mm
30 - 120mm ± 0.50mm

UNLESS OTHERWISE SPECIFIED TOLERANCES FOR INCHES ARE:
.020 - .315 = ± 0.007"
.315 - 1.180 = ± 0.015"
1.180 - 4.724 = ± 0.020"

DO NOT SCALE DRAWING

APPROVALS	DATE
DRAWN GRS	01/20/09
CHECKED	
ISSUED	
SHEET 1 OF 1	
CAD FILE	C:/122/122358.DWG

Amphenol Connex

PART DESCRIPTION			
TNC BULKHEAD CRIMP JACK (FOR RG-174/U, 316/U DOUBLE BRAID)			
PART NO. 122358			
DWG. NO.	122358.DWG	REV.	NC
SIZE	A	SCALE	NA