

REV.	DATE	ECR NO.	DESCRIPTION
A	01/24/06	-	ADD 50ohm TO DESCRIPTION/ UPDATE DRAWING FORMAT
B	12/03/08	100062	REVISE CABLE STRIPPING TO 4.5/ CONTACT PIN TO 13.75

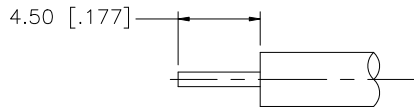

RECOMMENDED
CABLE STRIPPING DIM'S

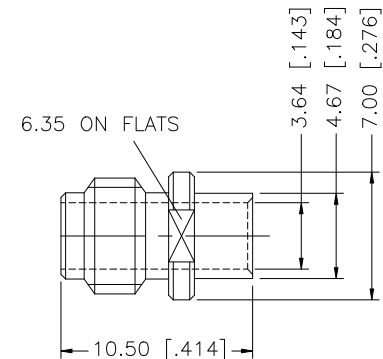
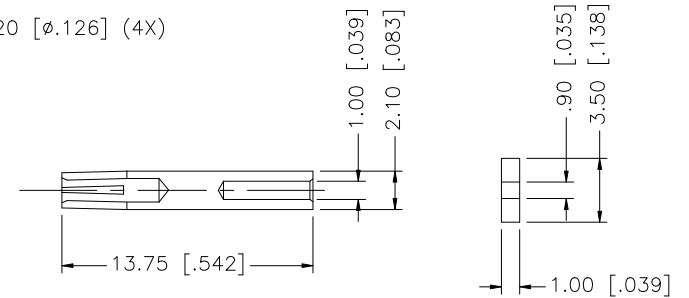
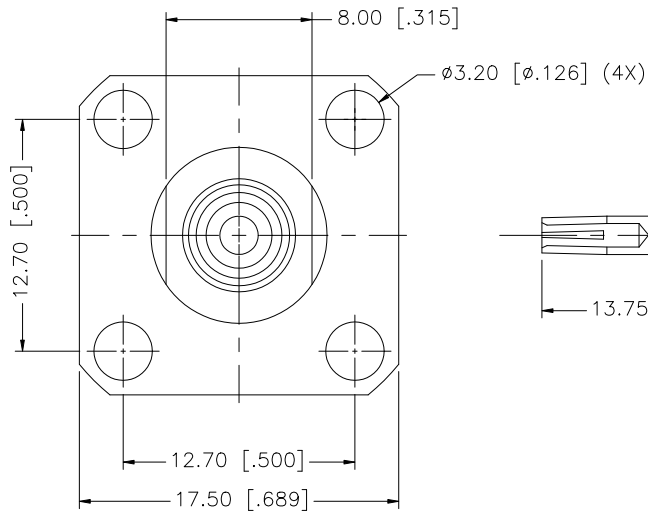
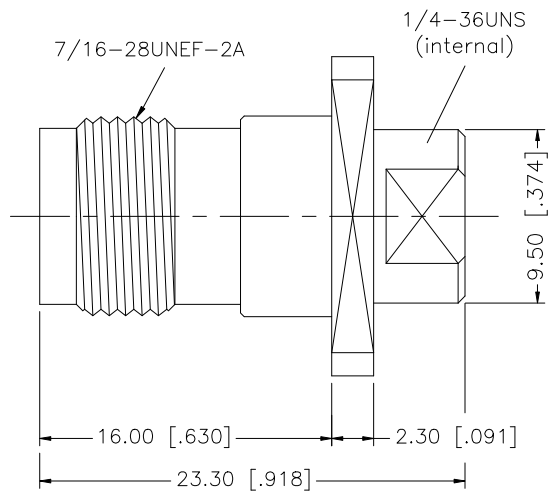

QTY	DESCRIPTION	MATERIAL	FINISH
1	INSULATOR	PTFE	NATURAL
2	INSULATOR	PTFE	NATURAL
3	CONTACT PIN	PHOS. BRONZE	GOLD
4	INSULATOR	PTFE	NATURAL
5	SOLDER NUT	BRASS	GOLD
6			
7			
8			

UNLESS OTHERWISE SPECIFIED DIMENSIONS ARE IN MILLIMETERS. DIMENSIONS IN [] ARE IN INCHES AND FOR CUSTOMER REFERENCE ONLY.

UNLESS OTHERWISE SPECIFIED TOLERANCES FOR MILLIMETERS ARE:
0.5 - 8mm ± 0.20mm
8 - 30mm ± 0.40mm
30 - 120mm ± 0.50mm

UNLESS OTHERWISE SPECIFIED TOLERANCES FOR INCHES ARE:
.020 - .315 ± 0.007"
.315 - 1.180 ± 0.015"
1.180 - 4.724 ± 0.020"

DO NOT SCALE DRAWING

APPROVALS	DATE
DRAWN GRS	12/03/08
CHECKED	
ISSUED	
SHEET 1 OF 1	
CAD FILE	C:/122/122419.DWG

PART DESCRIPTION			
Amphenol Connex			
TNC PANEL DIRECT SOLDER JACK (FOR .141" SEMI RIGID CABLE)			
PART NO. 122419			
DWG. NO.	122419.DWG	REV. B	SIZE A SCALE NA