

NOTES:

1. MATERIALS AND FINISHES:
 OUTER CONTACT- PHOSPHOR BRONZE, NICKEL PLATING (.0001" THICK)
 FRONT BODY - ZINC ALLOY, NICKEL PLATING (.00015" THICK)
 CRIMP CONTACT - BRASS, GOLD PLATING (.00003" THICK)
 INSULATOR - PTFE
2. ELECTRICAL:
 A. IMPEDANCE: 75 OHM
 B. FREQUENCY RANGE: DC - 3 GHz
 C. VSWR(RETURN LOSS): 1.10 UP TO 2 GHz(-26.44 dB), 1.16 UP TO 3 GHz(-22.61 dB)
 D. DIELECTRIC WITHSTANDING VOLTAGE: 1500 VRMS, MIN.
 E. WORKING VOLTAGE: 500 VAC PEAK
3. MECHANICAL:
 A. DURABILITY: 500 CYCLES MIN.
 B. TEMPERATURE RANGE: -40° C TO +85° C
4. PACKAGING:
 A. QUANTITY: SINGLE PACK
 B. MARKING: BAG TO BE MARKED
 "AMPHENOL, 31-80905, AND DATE CODE"
5. FOR CABLE STRIPPING AND ASSEMBLY INSTRUCTIONS SEE AMPHENOL SPEC 349-50756.
 FERRULE TO BE CRIMPED WITH A .178 HEX DIE.
 CONTACT TO BE CRIMPED WITH A .042 SQUARE DIE
 OR A 8 PT CRIMPER AMPHENOL NUMBER 227-T1200

THIRD ANGLE PROJ.

REVISIONS

REV	DESCRIPTION	DATE	ECO	APPR
A	RELEASE TO MFG.	8/17/06	46206	GSA
B	SEE SHEET 1	12/8/06	46362	GSA
C	NOTE 5 '8 PT CRIMPER AMPHENOL NUMBER CTL-T1200'	8/6/07	86681	TC
D	227-T1200 WAS CTL-T1200\RD-DM110704011	15-Jul-11	48649	DH
E	STAMP WAS CHANGED/ RD-DM110825011	07-Sep-11	48757	SCOTT

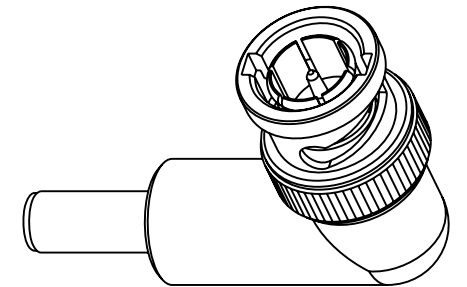

SCALE 1.500

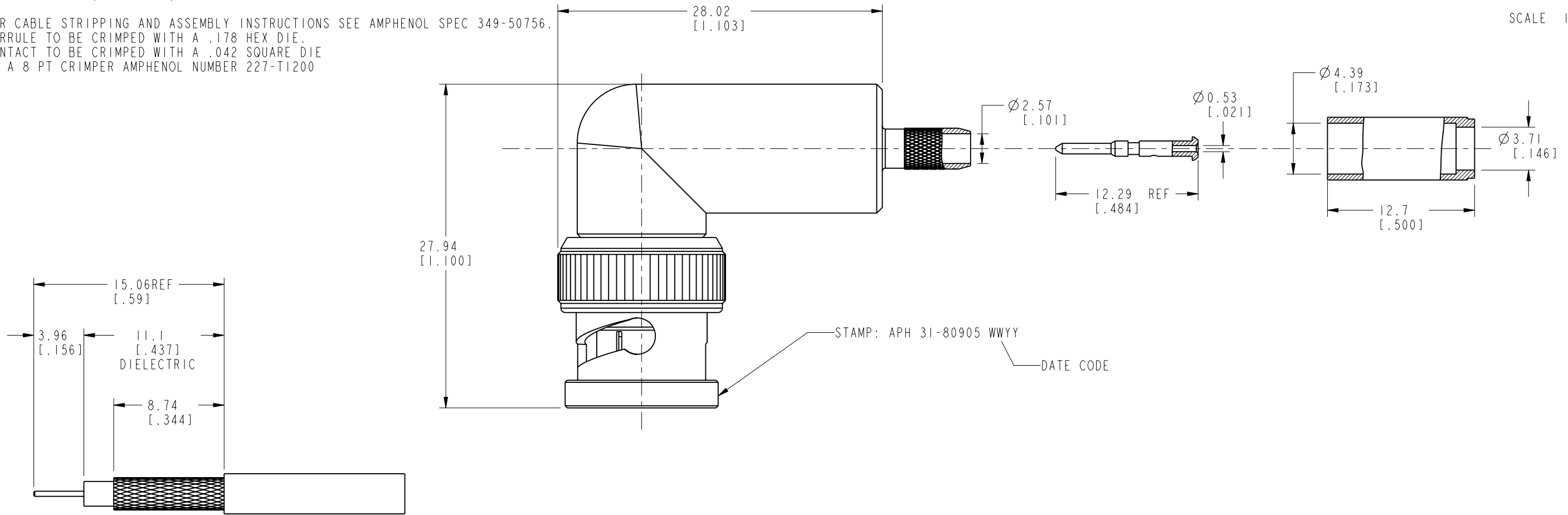

STAMP: APH 31-80905 WWYY
 DATE CODE

RECOMMENDED CABLE STRIPPING DIMENSIONS

SCALE 3.000

CUSTOMER OUTLINE DRAWING

ALL OTHER SHEETS ARE FOR INTERNAL USE ONLY

UNLESS OTHERWISE SPECIFIED, DIMENSIONS ARE IN METRIC AND TOLERANCES ARE: <0.5mm ±0.05mm 0.5 - 6mm ±0.1mm 6 - 30mm ±0.2mm 30 - 120mm ±0.3mm ANGLES ±1°	MATERIAL	DRAWN	DATE	TITLE BNC 90° ANGLE PLUG FOR AT&T 735 CABLE	Amphenol RF Danbury CT USA, Tainan, Taiwan, Shenzhen, China www.amphenolrf.com	
	SEE NOTE	I.XU	26-Aug-11			
NOTICE - These drawings, specifications, or other data (1) are, and remain the property of Amphenol corp. (2) must be returned upon request; and (3) are confidential and not to be disclosed to any person other than those to whom they are given by Amphenol Corp. the finishing of these drawings, specifications, or other data by Amphenol Corp., or to any other person to anyone for any purpose is not to be regarded by implication or otherwise in any manner licensing, granting rights to permitting such holder or any other person to manufacture, use or sell any product, process or design, patented or otherwise, that may in any way be related to or disclosed by said drawings, specifications, or other data.	REFERENCE	ENGINEER	DATE	SCALE: 2.8:1.0 SHEET 2 OF 2	DRAWING NO. 31-80905	
	EAR# 1674 AND 611x-4215	G. ANTONINI	29-Mar-05		ITEM NO. 31-80905	
	CONFIGURATION LEVEL: <input type="checkbox"/> <input type="checkbox"/> <input type="checkbox"/>	APPROVED	DATE	DWG SIZE B	REV E	PART NO. 31-80905
	FINISH	D.HU	05-Sep-11			