

NOTES:

- MATERIALS OF CONSTRUCTION:  
RING, END PLATE, HEX NUT = BRASS/NICKEL PLATED.  
BODY = ZINC DIE CAST/NICKEL PLATED.  
LOCKWASHER = PHOSPHOR BRONZE/NICKEL PLATED.  
CONTACT = PHOSPHOR BRONZE/GOLD PLATED.  
FRONT & REAR INSULATORS = PTFE.
- PACKAGE IN BAG, MARK BAG "31-70330".
- DO NOT SCALE THIS DRAWING.
- UNLESS OTHERWISE SPECIFIED, ALL DIMENSIONS ARE AFTER PLATING.

31-70330

REVISIONS

DRAWING NO.	REV	DESCRIPTION	DATE	ECO	APPR
THIRD ANGLE PROJ.	A	RELEASE TO MFG.	4/7/06	46016	CPM/
	B	SEE SHEET 1	2/17/09	47425	CPM/

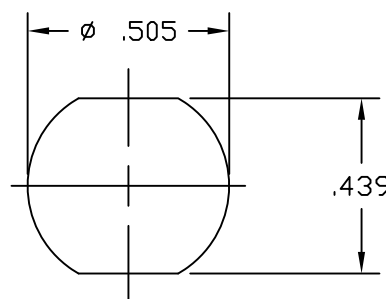
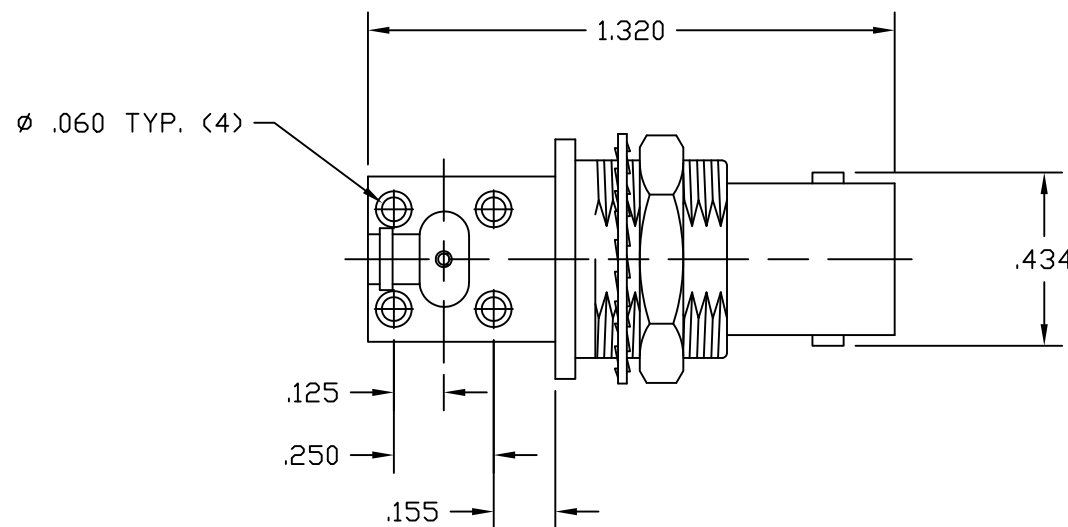
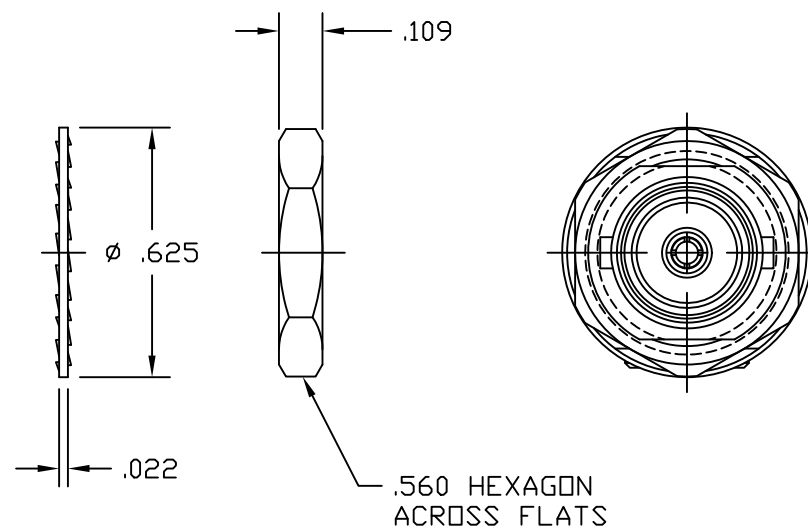
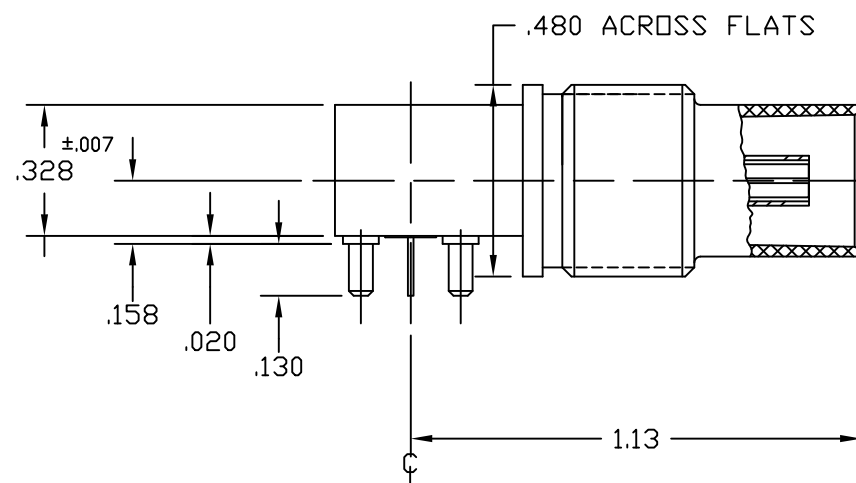
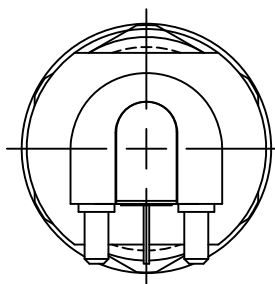

RECOMMENDED MOUNTING HOLE

CUSTOMER OUTLINE DRAWING  
ALL OTHER SHEETS ARE FOR INTERNAL USE ONLY

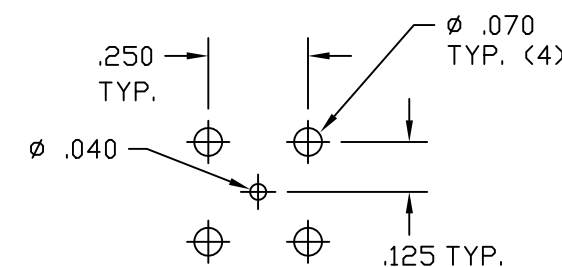

P/C MOUNTING HOLE PATTERN

UNLESS OTHERWISE SPECIFIED, DIMENSIONS ARE IN INCHES AND TOLERANCES ARE: 2 PLACE DECIMAL 3 PLACE DECIMAL ANGLES ±.015 (0,381 mm) ±.005 (0,127 mm) ± 1'	MATERIAL	DRAWN C. McGRATH	DATE 11/28/05	TITLE BNC RT. ANGLE PCB RECEPT.	Amphenol Amphenol Corporation RF/Microwave Operations Danbury, Conn. U.S.A. 06810
	REFERENCE	ENGINEER D. BARTHELMES	DATE 11/28/05		
NOTICE - These drawings, specifications, or other data (1) are, and remain the property of Amphenol Corp. (2) must be returned upon request; and (3) are confidential and not to be disclosed to any person other than those to whom they are given by Amphenol Corp. The furnishing of these drawings, specifications, or other data by Amphenol Corp., or to any other person to anyone for any purpose is not to be regarded by implication or otherwise in any manner licensing, granting rights or permitting such holder or any other person to manufacture, use or sell any product, process or design, patented or otherwise, that may in any way be related to or disclosed by said drawings, specifications, or other data.		APPROVED B.C. GLEISSNER	DATE 4/7/06	SCALE: 2:1	SHEET 2 OF 2
		CAD FILE H:\DEPT611\BNC\031\ASSY\70330SH2	CODE ID 74868	DWG SIZE B	DRAWING NO. 31-70330