

NOTES:

1. MATERIALS AND FINISHES:
 BODY - ZINC DIE CAST, NICKEL PLATING
 CONTACT - PHOSPHOR BRONZE, GOLD PLATING (.000003 THICK)
 @ CONTACT AREA ONLY, TIN PLATING AT TAIL, NICKEL PLATED OVERALL
 INSULATOR - POLYPROPYLENE
 ROUND PIN - BRASS, TIN PLATING
 GROUNDING TERMINAL - STEEL, TIN PLATING
2. ELECTRICAL:
 A. IMPEDANCE: 50 OHM
 B. FREQUENCY RANGE: DC - 1 GHz
 C. DIELECTRIC WITHSTANDING VOLTAGE: 1500 VRMS, MIN.
3. MECHANICAL:
 A. DURABILITY: 500 CYCLES MIN.
 B. TEMPERATURE RANGE: -55° C TO 85° C
4. PACKAGING:
 A. PACKAGED IN PACKING TRAYS
 B. QUANTITY PER TRAY: 40

THIRD ANGLE PROJ.

REVISIONS

REV	DESCRIPTION	DATE	ECO	APPR
-	RELEASE TO MFG	12-10-92	39213	JM/RV
D	SEE SHEET I	6-16-05	45589	CPM/
E	SEE SHEET I	1/15/08		
F	UPDATED NOMINAL ENVELOPE DIMENSIONS	12/10/12	49031	EW

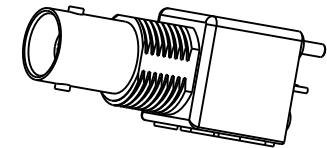

SCALE 1.000

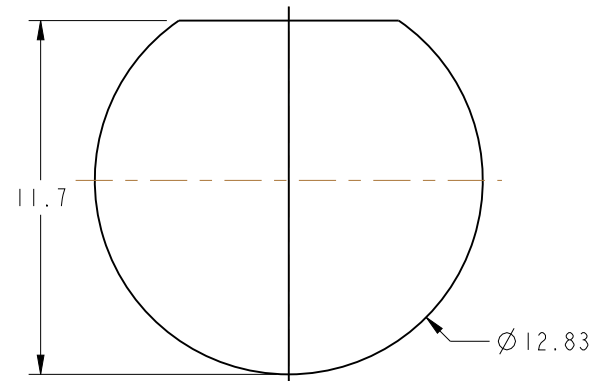

PANEL CUTOUT

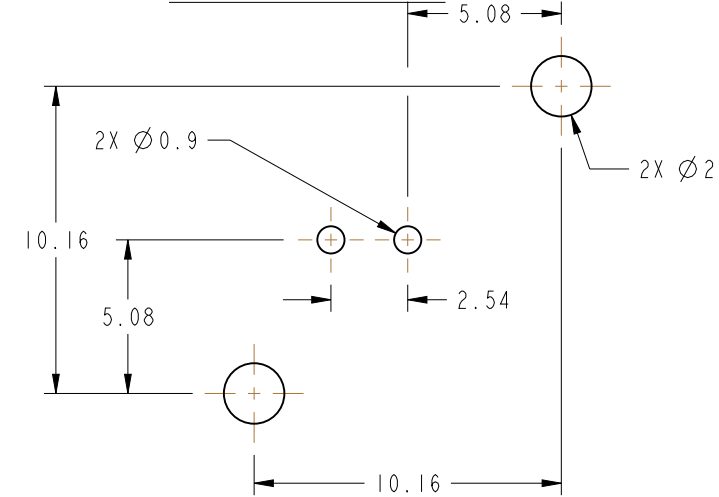

RECOMMENDED PCB LAYOUT

BNC PER MIL-STD-348

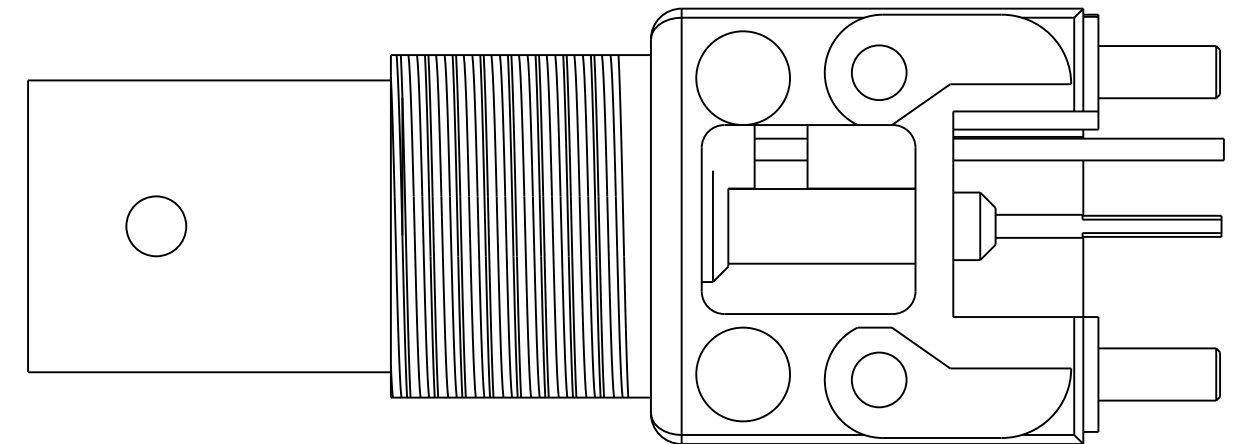
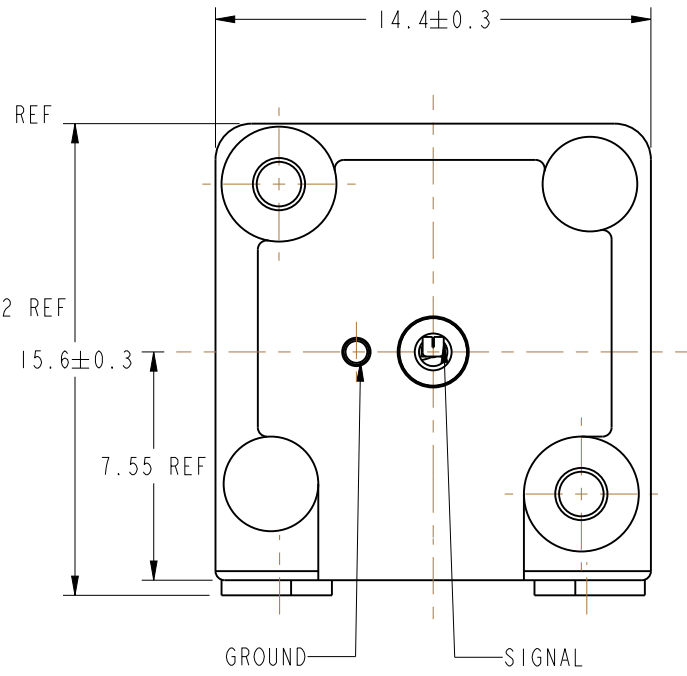
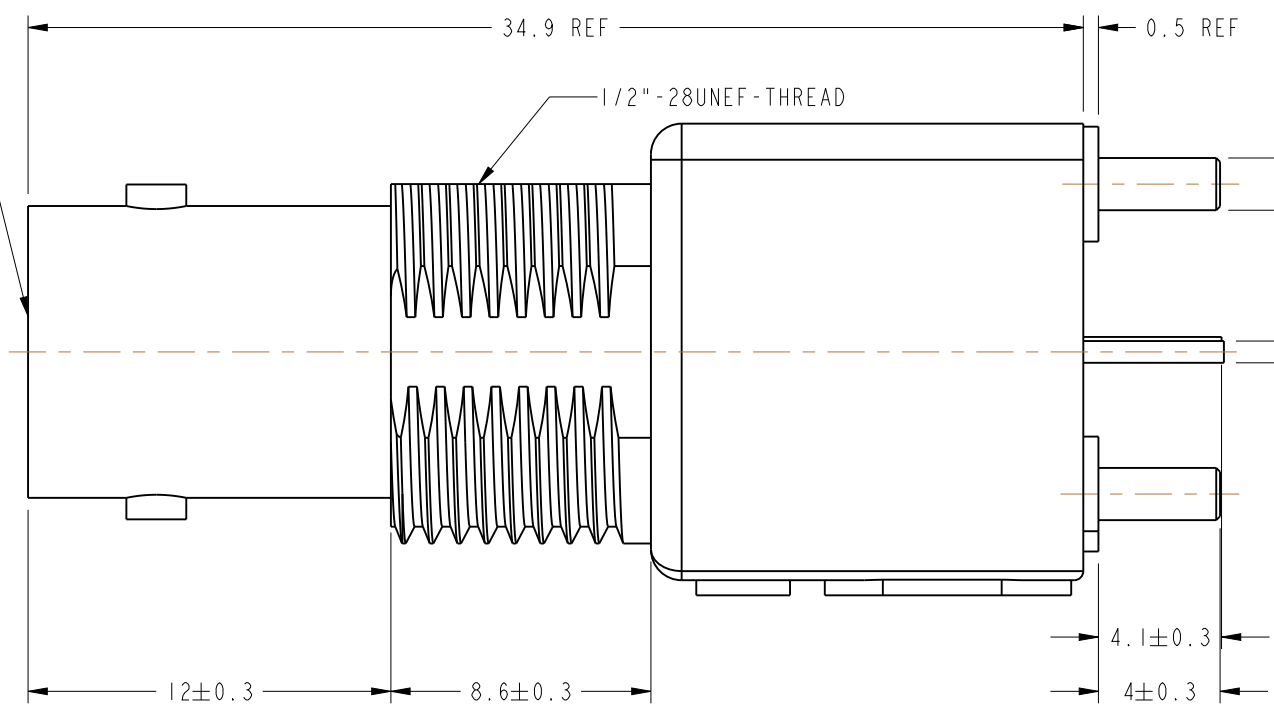

CUSTOMER OUTLINE DRAWING

ALL OTHER SHEETS ARE FOR INTERNAL USE ONLY

UNLESS OTHERWISE SPECIFIED, DIMENSIONS ARE IN METRIC AND TOLERANCES ARE: <0.5mm ±0.05mm 0.5 - 6mm ±0.1mm 6 - 30mm ±0.2mm 30 - 120mm ±0.3mm ANGLES ±1°	MATERIAL	DRAWN	DATE	TITLE 50 OHM BNC STR JACK		Amphenol RF www.amphenolrf.com	
		ERIC WANKOFF	27-Jun-12				
	REFERENCE	ENGINEER	DATE	SCALE: 4.0:1.0 SHEET 2 OF 2		DRAWING NO. 31-5633	
		R. VACCARO	11/6/92				
CONFIGURATION LEVEL:	APPROVED	DATE	DWG SIZE B REV F		ITEM NO. 31-5633		
	J. MULVEY	8/26/92					
FINISH	CAD FILE					PART NO. 31-5633	

NOTICE - These drawings, specifications, or other data (1) are, and remain the property of Amphenol corp. (2) must be returned upon request; and (3) are confidential and not to be disclosed to any person other than those to whom they are given by Amphenol Corp. the finishing of these drawings, specifications, or other data by Amphenol Corp., or to any other person to anyone for any purpose is not to be regarded by implication or otherwise in any manner licensing, granting rights to permitting such holder or any other person to manufacture, use or sell any product, process or design, patented or otherwise, that may in any way be related to or disclosed by said drawings, specifications, or other data.