

NOTES:

- MATERIALS AND FINISHES:
 BODY - BRASS, NICKEL PLATING
 CONTACT - BRASS, GOLD PLATING
 INSULATOR - PTFE, NATURAL
- ELECTRICAL:
 A. IMPEDANCE: 50 OHM
 B. FREQUENCY RANGE: DC 0-2 GHz
 C. DIELECTRIC WITHSTANDING VOLTAGE: 1500 VRMS, MIN.
- MECHANICAL:
 A. DURABILITY: 500 CYCLES MIN.
 B. TEMPERATURE RANGE: - 65°C to +165°C
- SOLDER CONTACT TO CABLE.
 WHEN CRIMPING CONTACT TO CABLE, CRIMP WITH AMPHENOL TOOL 227-944 (M22520/5-01) AND DIE SET 227-1221-13, CAVITY 'B' (M22520/5-13, CLOSURE 'B')
- WHEN CRIMPING FERRULE TO CABLE, CRIMP WITH AMPHENOL TOOL 277-944 (M22520/5-01) AND DIE SET 227-1221-13 CAVITY 'A' (M22520/5-13 CLOSURE 'A')
- USE WITH BELDEN 1505A, 1426A, 9659, 9259, 9240, 8212, 9274, 9275, 9100 CABLES AND CLARK CV7559 CABLES.

THIRD ANGLE PROJ.

REVISIONS

REV	DESCRIPTION	DATE	ECO	APPR
A2	SEE SHEET 1	27-Jul-05	41541	SH
A3	SEE SHEET 1	16-Aug-05	--	SH
B	SEE SHEET 1	27-Feb-08	--	AW
K	REDRAWN TO UPDATE FORMAT	29-Dec-08	47204	SH
L	SEE SHEET 1	09-Sep-10	47967	SH
M	NOTE 4 WAS CHANGED\RD-10121301F	27-Dec-10	48342	SH

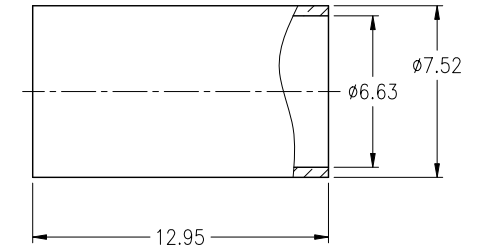
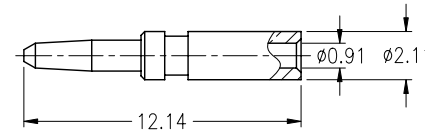
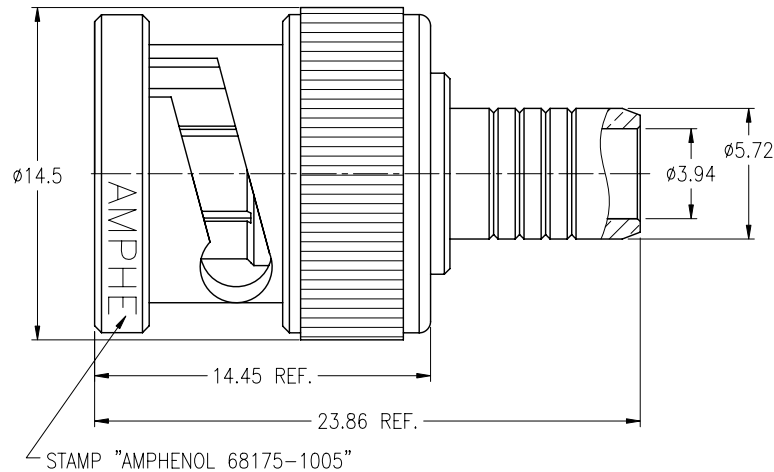
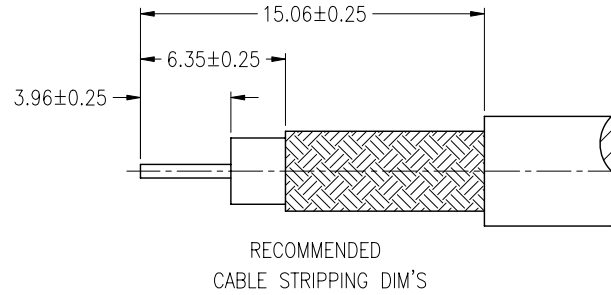

THIS CONNECTOR IS COVERED BY U.S. PATENT 3,336,563

CUSTOMER OUTLINE DRAWING
 ALL OTHER SHEETS ARE FOR INTERNAL USE ONLY

UNLESS OTHERWISE SPECIFIED, DIMENSIONS ARE IN METRIC AND TOLERANCES ARE:
 <0.5mm ±0.05mm 0.5 - 6mm ±0.1mm 6 - 30mm ±0.2mm 30 - 120mm ±0.3mm ANGLES ±1°

NOTICE - These drawings, specifications, or other data (1) are, and remain the property of Amphenol Corp. (2) must be returned upon request; and (3) are confidential and not to be disclosed to any person other than those to whom they are given by Amphenol Corp. The furnishing of these drawings, specifications, or other data by Amphenol Corp., or to any other person to anyone for any purpose is not to be regarded by implication or otherwise in any manner licensing, granting rights or permitting such holder or any other person to manufacture, use or sell any product, process or design, patented or otherwise, that may in any way be related to or disclosed by said drawings, specifications, or other data.

MATERIAL	DRAWN F.WANG	DATE 27-Dec-10	TITLE BNC PLUG QUICK CRIMP FOR RG59/U TYPE CABLE .032 CENTER CONDUCTOR			Amphenol RF Danbury CT USA, Tainan Taiwan, Shenzhen China www.amphenolrf.com	
REFERENCE	ENGINEER S.LI	DATE 27-Dec-10	APPROVED S.HSIEH			DRAWING NO.	68175-1005
FINISH	CAD FILE F:\DWG\CNPD\68175\1005-MSZ	DATE 27-Dec-10	SCALE: 3/1	SHEET 2 OF 2	ITEM NO.	68175-1005	
			DWG SIZE B	CODE ID 74868	REV M	PART NO.	68175-1005