

NOTES:

1. MATERIALS AND FINISHES(PLATING THICKNESS IN MICRO-INCHES):
 BODY - BRASS, NICKEL PLATING
 CONTACT - BRASS, SILVER PLATING
 INSULATOR - PTFE, NATURAL
2. ELECTRICAL:
 A. IMPEDANCE: 50 OHM
 B. FREQUENCY RANGE: DC 0-4 GHz
 C. DIELECTRIC WITHSTANDING VOLTAGE: 1500 VRMS, MIN.
3. MECHANICAL:
 A. DURABILITY: 500 CYCLES MIN.
 B. TEMPERATURE RANGE: -65°C to +165°C
4. SOLDER CONTACT TO CABLE
 WHEN CRIMPING CONTACT TO CABLE, AMPHENOL TOOL NO. 227-944 WITH DIE SET NO. 227-1221-13 CAVITY "B" IS RECOMMENDED.

THIRD ANGLE PROJ.

REVISIONS

REV	DESCRIPTION	DATE	ECO	APPR
A2	SEE SHEET 1	09-Jun-04		
A3	SEE SHEET 1	28-Jan-05		
B	SEE SHEET 1	22-Sep-05		
C	SEE SHEET 1	13-Apr-07		
D	SEE SHEET 1	10-Mar-08		AW
U	SEE SHEET 1	12-Jan-10	47921	SH
V	NOTE 4 WAS CHANGED\RD-DM11011001I	12-Jan-11	48420	SH
W	P/N. OF INSULATOR WAS CHANGED\ RD-DM111103011 MAIN BODY PN WAS CHANGED\RD-DM111117011	25-Nov-11	48853	DH

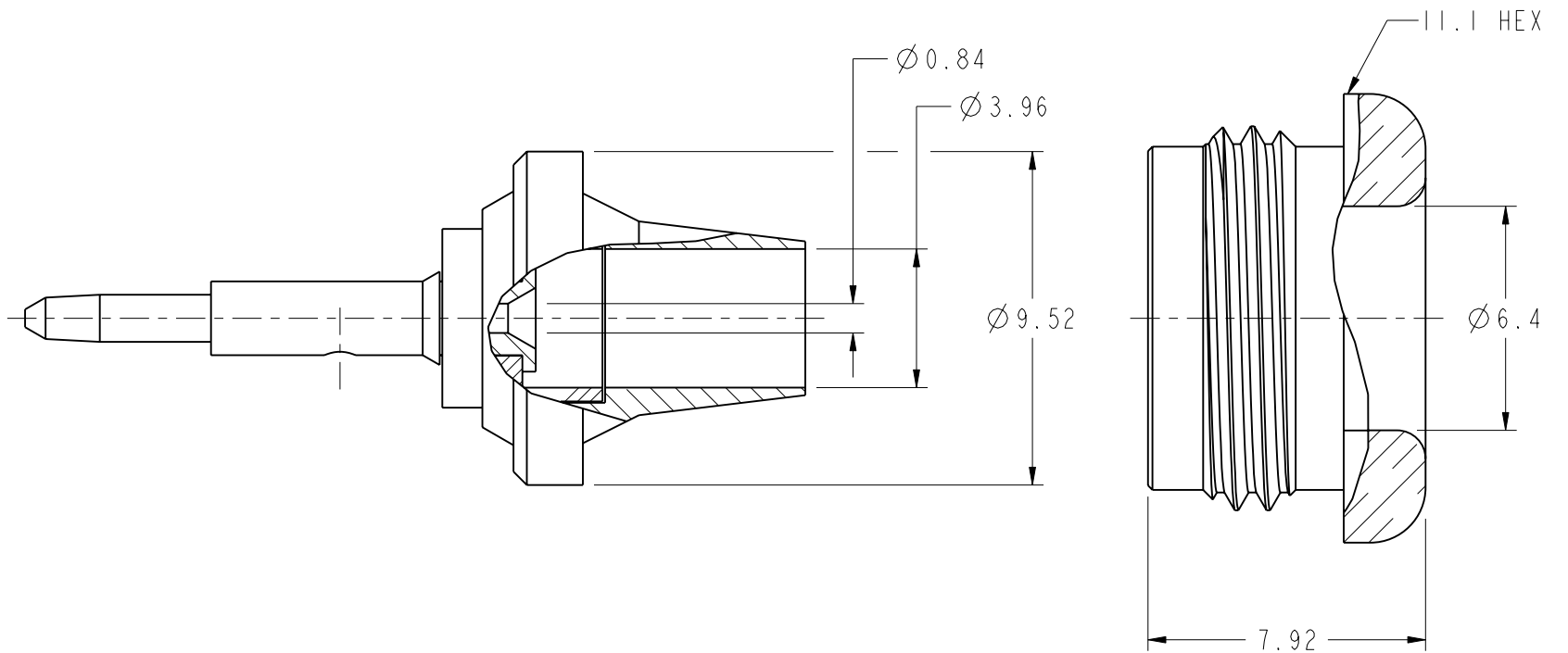
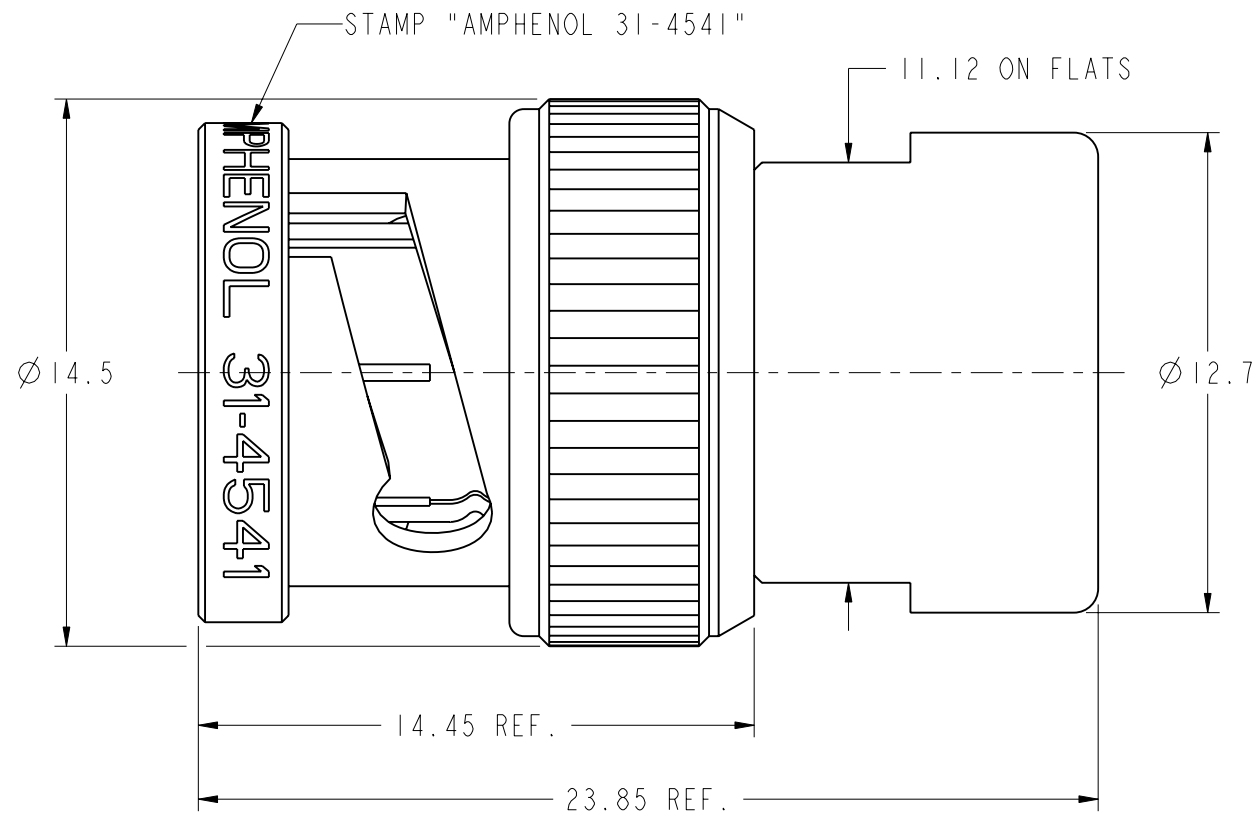
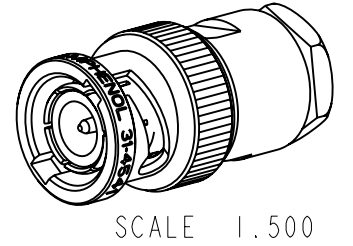
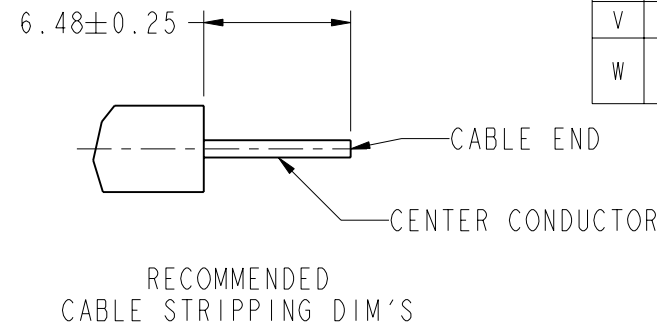

CUSTOMER OUTLINE DRAWING
 ALL OTHER SHEETS ARE FOR INTERNAL USE ONLY

UNLESS OTHERWISE SPECIFIED, DIMENSIONS ARE IN METRIC AND TOLERANCES ARE: <0.5mm ±0.05mm 0.5 - 6mm ±0.1mm 6 - 30mm ±0.2mm 30 - 120mm ±0.3mm ANGLES ±1°	MATERIAL	DRAWN	DATE	TITLE		Amphenol RF Danbury CT USA, Tainan, Taiwan, Shenzhen, China www.amphenolrf.com		
	SEE NOTES	I.XU	15-Nov-11					BNC PLUG
	REFERENCE	ENGINEER	DATE	SCALE: 5.0:1.0 SHEET 2 OF 2				DRAWING NO. 31-4541
	FINISH	D.HU	25-Nov-11	DWG SIZE	REV			ITEM NO. 31-4541
NOTICE - These drawings, specifications, or other data (1) are, and remain the property of Amphenol corp. (2) must be returned upon request; and (3) are confidential and not to be disclosed to any person other than those to whom they are given by Amphenol Corp. the finishing of these drawings, specifications, or other data by Amphenol Corp., or to any other person to anyone for any purpose is not to be regarded by implication or otherwise in any manner licensing, granting rights to permitting such holder or any other person to manufacture, use or sell any product, process or design, patented or otherwise, that may in any way be related to or disclosed by said drawings, specifications, or other data.		I:/BNC/31-4541		B	W	PART NO. 31-4541		