

NOTES:

1. MATERIALS AND FINISHES
 BODY - BRASS, NICKEL PLATING
 CONTACT - PHOSPHOR BRONZE, GOLD PLATING
 INSULATOR - PTFE
2. ELECTRICAL:
 A. IMPEDANCE: 50 OHM
 B. FREQUENCY RANGE: DC 0-11 GHz
 C. DIELECTRIC WITHSTANDING VOLTAGE: 2500 VRMS, MIN.
3. MECHANICAL:
 A. DURABILITY: 500 CYCLES MIN.
 B. TEMPERATURE RANGE: - 65°C to +165°C
4. CRIMPED FERRULE
 HEX CRIMP SIZE .429"
5. CRIMPED CONTACT PIN
 HEX CRIMP SIZE .100"
6. MAX. PANEL THICKNESS=6.5mm

THIRD ANGLE PROJ.

REVISIONS

REV	DESCRIPTION	DATE	ECO	APPR
B	SEE SHEET 1	22-Apr-08	--	SH
C	REDRAWN TO UPDATE FORMAT	26-Dec-08	47180	SH
D	LOCK WASHER WAS CHANGED	05-Mar-12	48832	SH

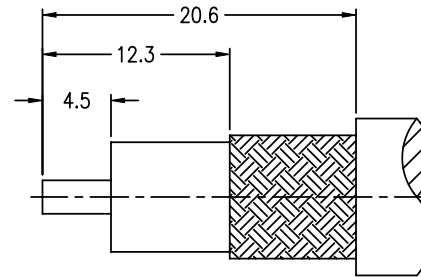

RECOMMENDED
CABLE STRIPPING DIM'S

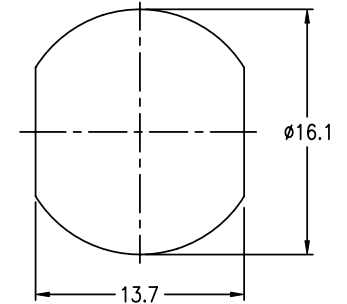

RECOMMENDED
MOUNTING HOLE

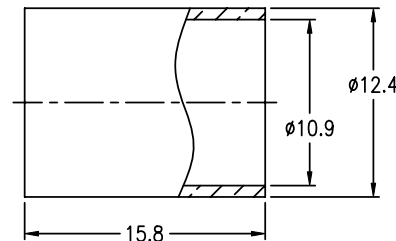
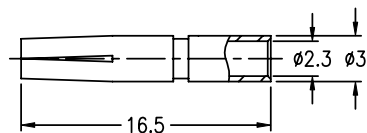
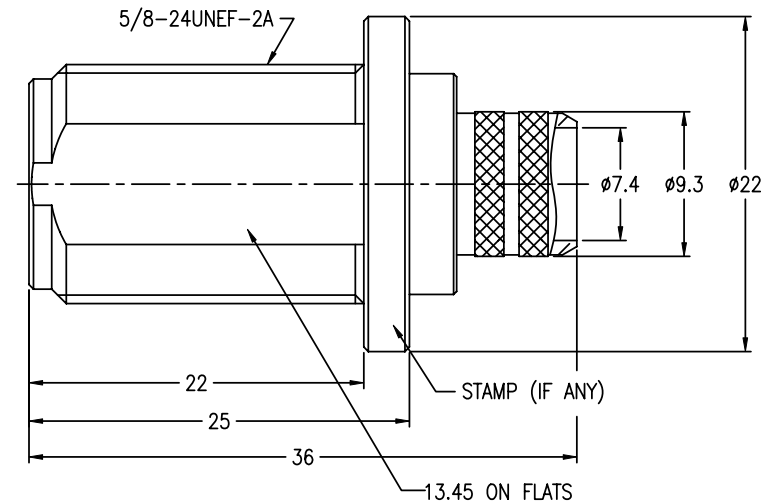
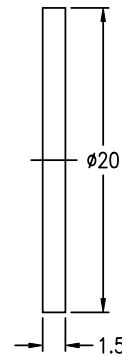
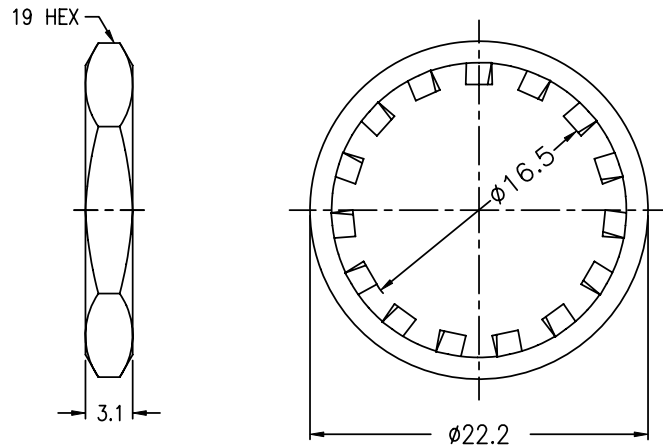

CUSTOMER OUTLINE DRAWING

ALL OTHER SHEETS ARE FOR INTERNAL USE ONLY

UNLESS OTHERWISE SPECIFIED, DIMENSIONS ARE IN METRIC AND TOLERANCES ARE:
 0.5 - 6mm ±0.1mm 6 - 30mm ±0.2mm 30 - 120mm ± 0.3mm ANGLES ±1°

NOTICE - These drawings, specifications, or other data (1) are, and remain the property of Amphenol Corp. (2) must be returned upon request; and (3) are confidential and not to be disclosed to any person other than those to whom they are given by Amphenol Corp. The furnishing of these drawings, specifications, or other data by Amphenol Corp., or to any other person to anyone for any purpose is not to be regarded by implication or otherwise in any manner licensing, granting rights or permitting such holder or any other person to manufacture, use or sell any product, process or design, patented or otherwise, that may in any way be related to or disclosed by said drawings, specifications, or other data.

MATERIAL	DRAWN TOMMY.HU	DATE 05-Mar-12	TITLE N BULKHEAD CRIMP JACK			Amphenol RF Danbury CT USA, Tainan Taiwan, Shenzhen China www.amphenolrf.com	
REFERENCE	ENGINEER C.WANG	DATE 22-Apr-08	SCALE: 2/1 SHEET 2 OF 2			DRAWING NO. N6421A1-NT3G-8U-50	
FINISH	APPROVED S.HSIEH	DATE 05-Mar-12				DWG SIZE B	
	F:\N\6421A1\8U-50\NT3G-DSZ		ITEM NO. 036421AAA81NA5F		PART NO. 82-346-RFX		