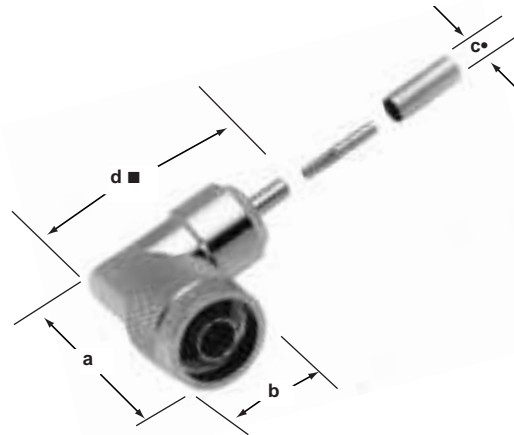
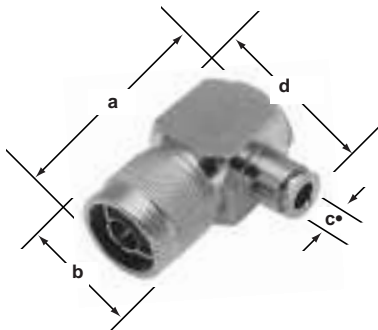

Fig. 1



Crimp N Angle Plugs
82-4440-1001 82-5995
82-5374 82-4440

Fig. 2



Clamp N Angle Plug
Cubic Body
18750
82-5988-1000

Fig. 3

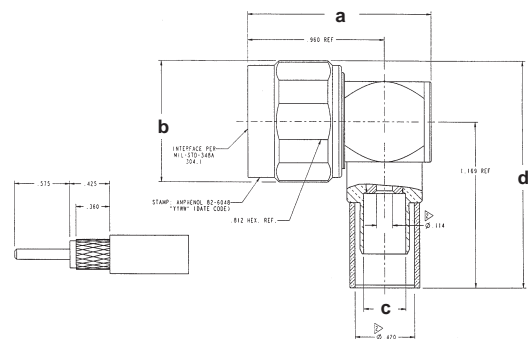

Crimp N Angle Plug
Cubic Body
82-6048-1000
82-5989-1004
82-6157
82-6165
82-6166

N RIGHT ANGLE PLUGS

Cable RG-/U	Cable Attachment		Dimensions, inches (millimeters)				Notes			Military Number	Amphenol Number	Fig.
	Outer	Inner	a	b	c •	d	CAI	Plt.	Ins.			
9, 214, 225, 393	Crimp	Crimp	1.40(35.5)	.827(21.0)	.437(11.1)	1.95(49.5)■	C11	P28	D1	—	82-4440-1001	1
55, 142, 223	Crimp	Crimp	1.41(35.7)	.827(21.0)	.220(5.6)	1.98(50.2)■	C11	P11	D1	—	82-5374	1 ▲
58, 141, 142	Clamp	Solder	1.63(41.3)	.827(21.0)	.210(5.3)	1.22(31.0)	C8	P1	D1	—	18750	2
214, 225, 393	Crimp	Crimp	1.40(35.5)	.827(21.0)	.438(11.1)	1.95(49.5)■	C11	P33	D1	M39012/05-0501	82-4440	1 ▲
214, 393	Crimp	Solder	1.195(30.4)	.827(21.0)	.438(11.1)	1.62(4.1)■	C11	P33	D9	—	82-5988-1000	2
214, 393	Crimp	Solder	1.195(30.4)	.850(21.6)	.438(11.1)	1.62(4.1)■	C11	P33	D9	Hex Coupling	82-5988-1004	3
LMR 600, TWB 6001	Crimp	Solder	1.32(33.5)	.850(21.6)	.625(15.9)	1.61(40.9)■	C11	P34	D9	Hex Coupling	82-5995	1
Amph TWB 4001, LMR 400, Belden 9913	Crimp	Solder	1.291(32.8)	.850(21.6)	.298(7.57)	1.594(40.5)■	C11	P33	D9	—	82-6048-1000	3
LMR 240, 8X	Crimp	Crimp	1.43(36.5)	.827(21.0)	.259(6.6)	1.07(27.2)	C11	P7	D1	Nickel body	82-6157	3
LMR 240, 8X	Crimp	Crimp	1.43(36.5)	.827(21.0)	.259(6.6)	1.07(27.2)	C11	P7	D1	Nickel body	82-6165	3
LMR 240, 8X	Crimp	Crimp	1.43(36.5)	.827(21.0)	.259(6.6)	1.07(27.2)	C11	P33	D1	Silver body	82-6166	3

• accommodates cable diameter ■ includes outer ferrule ▲ Distributor stocked