

NOTES:

1. MATERIALS AND FINISHES:
 BODY - BRASS, NICKEL PLATING
 CONTACT - BeCu, GOLD PLATING
 CONTACT - BRASS, GOLD PLATING
 INSULATOR - PTFE
 COUPLING NUT - BRASS, NICKEL PLATING
 GASKET - SILICONE RUBBER
 FERRULE - SEAMLESS COPPER, NICKEL PLATING
 HEAT SHRINK TUBING - CROSSLINKED POLYOLEFIN

2. ELECTRICAL:
 A. IMPEDANCE: 50 OHM
 B. FREQUENCY RANGE: DC - 6 GHz
 C. DIELECTRIC WITHSTANDING VOLTAGE: 1000 VRMS, MIN.

3. MECHANICAL:
 A. DURABILITY: 500 CYCLES MIN.
 B. TEMPERATURE RANGE: -40° C TO +85° C

4. PACKAGING:
 A. QUANTITY: SINGLE PACK
 B. MARKING: BAG TO BE MARKED
 "AMPHENOLRF, 31-6365, AND DATE CODE"

5. CABLE ASSEMBLY INSTRUCTIONS:
 A. TRIM CABLE AS SHOWN.
 B. SLIDE HEAT SHRINK TUBING, FERRULE AN INSULATOR DISC ONTO CABLE.
 C. SOLDER CABLE CENTER CONDUCTOR TO BULLET CONTACT.
 D. INSERT CABLE WITH FOIL ENTERING CONNECTOR AND BRAID OVER KNURL.
 E. CRIMP FERRULE OVER BRAID WITH 0.213" HEX DIE.
 F. APPLY HEAT SHRINK TUBING OVER FERRULE.
 G. HEAT SHRINK TUBING SHOULD FULLY (360 DEG) COVER THE BUMP ON BODY AND END WITHIN AREA "A"

6. RECOMMENDED COUPLING TORQUE : 4-6 IN-LBS.

7. SHOWS CABLE ENTRY DIMENSIONS.

THIRD ANGLE PROJ.

REVISIONS

REV	DESCRIPTION	DATE	ECO	APPR
A	RELEASE TO MFG.	18-Jul-12	48949	DD
B	ADDED ARC LOGO TO COUPLING NUT & AMPHENOL RF TO HST RD-DM13022001R3	1-Mar-13	49418	RM

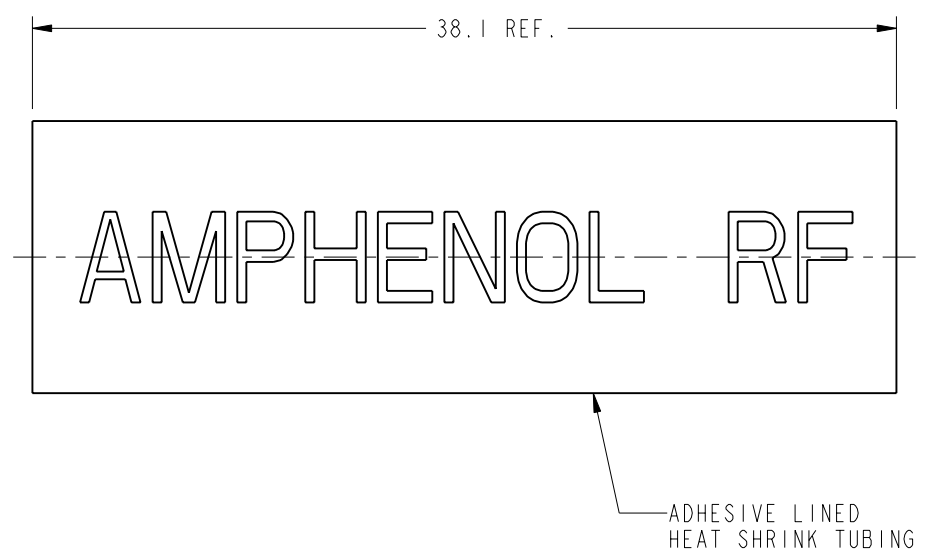
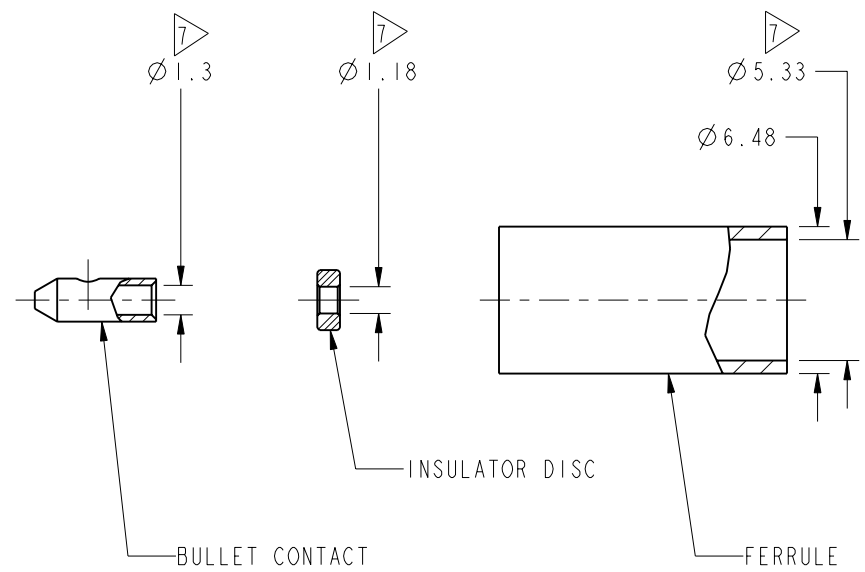
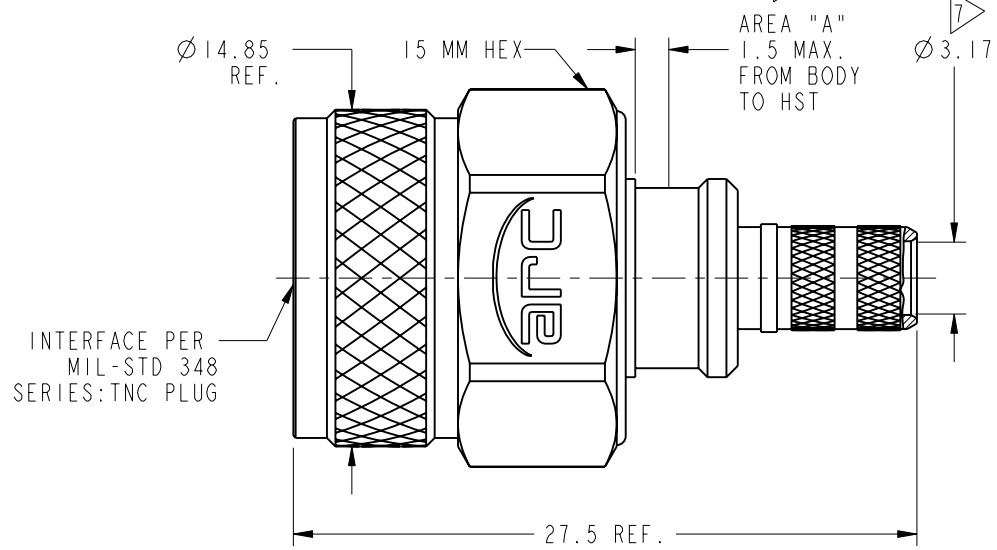
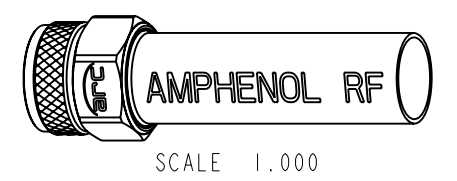
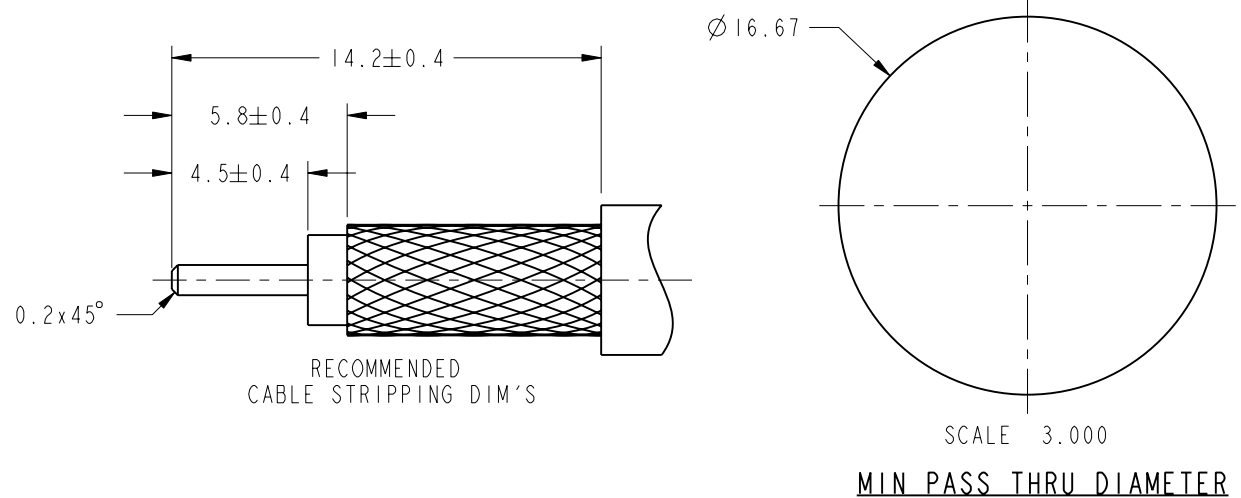

CUSTOMER OUTLINE DRAWING
 ALL OTHER SHEETS ARE FOR INTERNAL USE ONLY

UNLESS OTHERWISE SPECIFIED, DIMENSIONS ARE IN METRIC AND TOLERANCES ARE: <0.5mm ±0.05mm 0.5 - 6mm ±0.1mm 6 - 30mm ±0.2mm 30 - 120mm ±0.3mm ANGLES ±1°	MATERIAL	DRAWN R. MAO	DATE 27-Feb-13	TITLE STR IP-67 TNC, PLUG FOR LMR-200 CABLE	Amphenol RF www.amphenolrf.com	
	REFERENCE AND CONFIGURATION LEVEL: <input type="checkbox"/> <input type="checkbox"/> <input type="checkbox"/>	ENGINEER D. DAVE	DATE 31-Aug-11			DRAWING NO. 31-6499
NOTICE - These drawings, specifications, or other data (1) are, and remain the property of Amphenol corp. (2) must be returned upon request; and (3) are confidential and not to be disclosed to any person other than those to whom they are given by Amphenol Corp. the furnishing of these drawings, specifications, or other data by Amphenol Corp., or to any other person for any purpose is not to be regarded by implication or otherwise in any manner licensing, granting rights to permitting such holder or any other person to manufacture, use or sell any product, process or design, patented or otherwise, that may in any way be related to or disclosed by said drawings, specifications, or other data.	FINISH	APPROVED S. HSIEH	DATE 27-Feb-13	SCALE: 4.0:1.0	SHEET 2 OF 2	
			CAD FILE		DWG SIZE B	REV B
						ITEM NO. 31-6499
						PART NO. 31-6499