

NOTES:

1. MATERIALS AND FINISHES:
 BODY - BRASS, ALBALOY PLATING
 CONTACT - BRASS, GOLD PLATING
 INSULATOR - PTFE
2. PHYSICAL:
 A) TEMPERATURE RANGE = -65°C TO +165°C
 B) INTERFACE = PER MIL-STD-348, TYPE N SERIES
 C) CONTACT AND INSULATOR MUST WITHSTAND
 6 IN OZ. TORQUE WITHOUT TURNING
3. ELECTRICAL:
 A) FREQUENCY RANGE = DC TO 11 GHz
 B) VSWR = 1.3 MAX.
4. PACKAGING:
 A. PACK ONE CONNECTOR IN A BAG AND MARK ON THE BAG: 6600-1401
 82-6410
 B. PACK TWENTY-FIVE WRAPPED CONNECTORS IN A MASTER BAG
 AND MARK ON THE MASTER BAG: "LORCH P/N: 6600-1401
 P/N: 82-6410

THIRD ANGLE PROJ.

REVISIONS

REV	DESCRIPTION	DATE	ECO	APPR
A	RELEASE TO MFG.	23-Mar-07		KL
A1	ADDED NOTE 4.	24-Apr-07	46511	MS
B	THE PACKAGE MARKING WAS CHANGED/RD-DM09030601S1	18-Mar-09	--	SH
C	UPDATE THE DRAWING	8-Jul-09	47563	SH

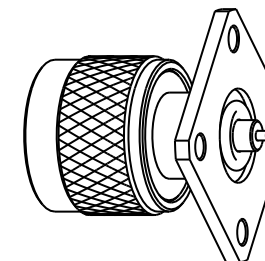

SCALE 1.000

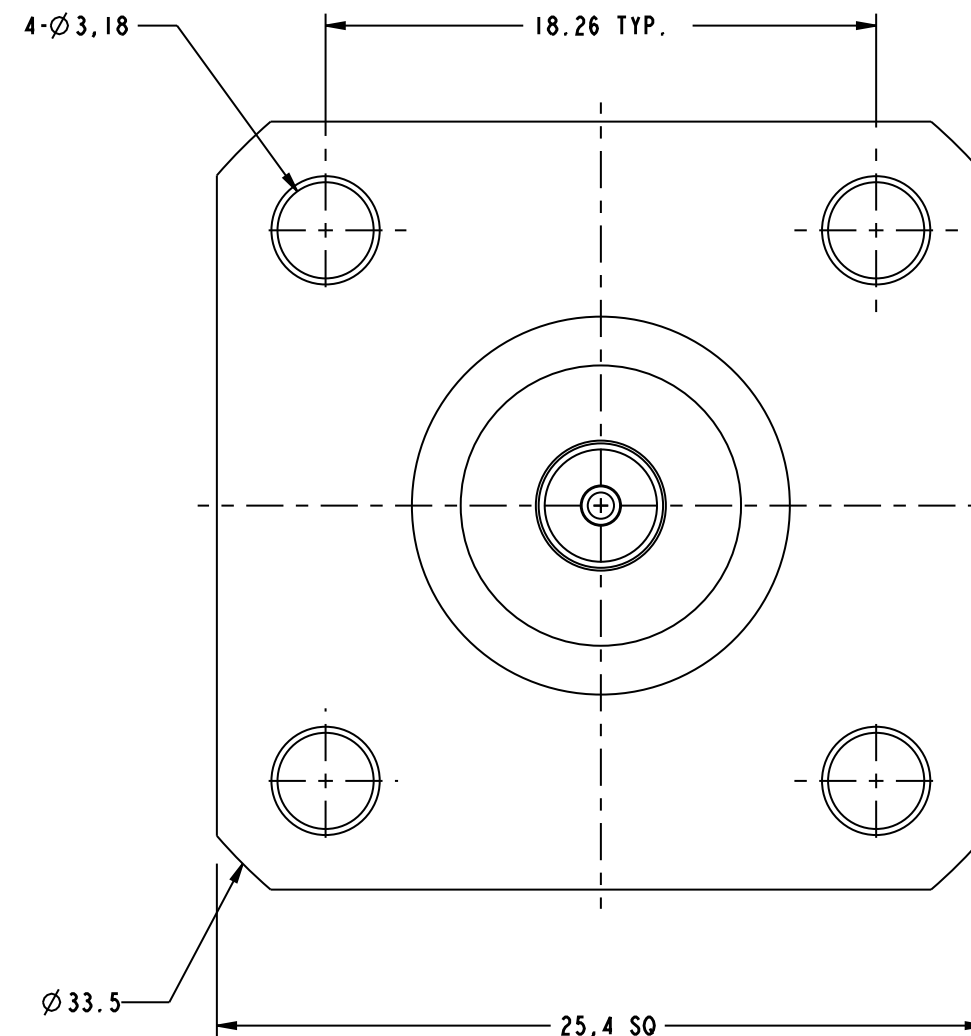
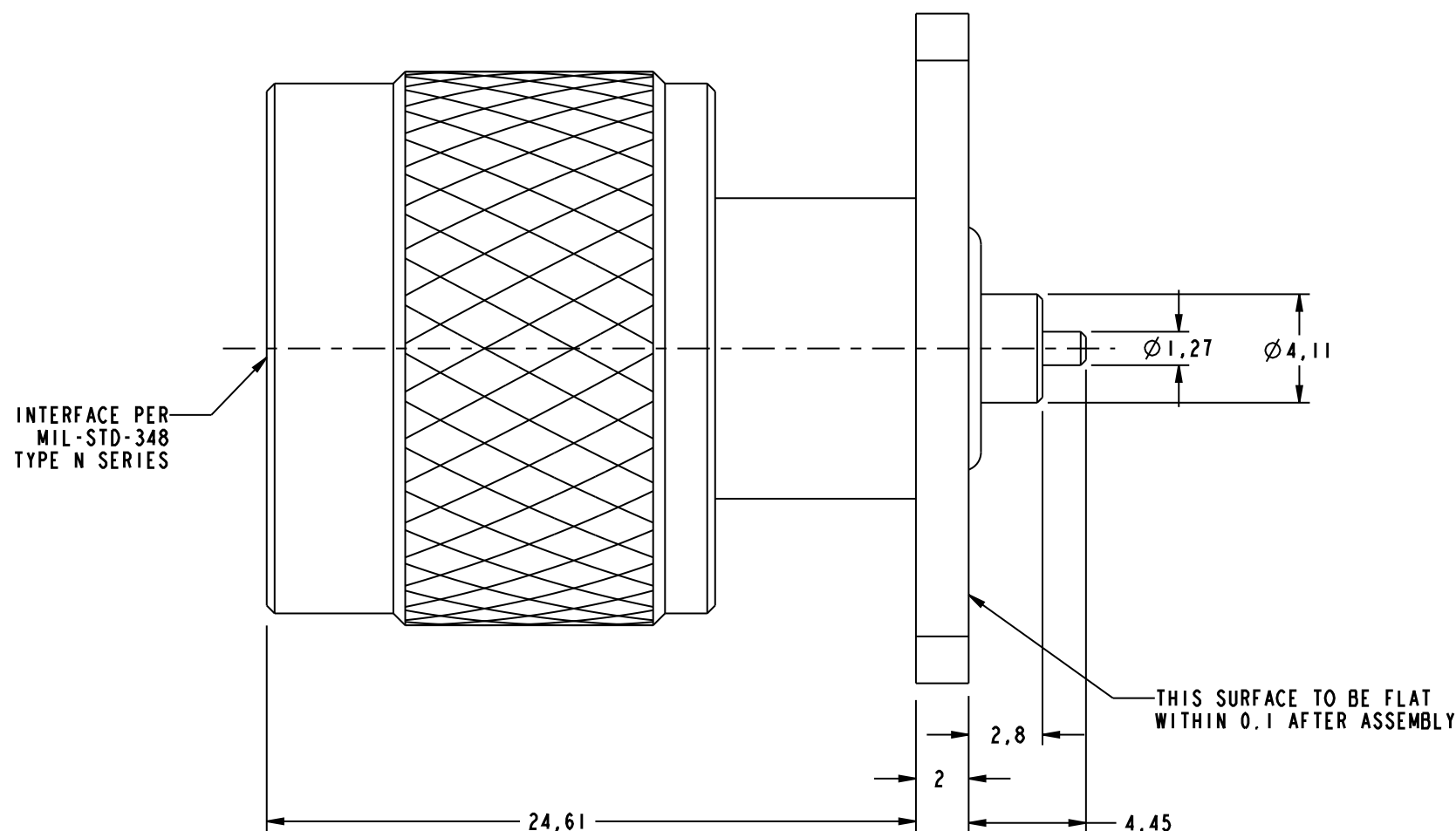

UNLESS OTHERWISE SPECIFIED, DIMENSIONS ARE IN METRIC AND TOLERANCES ARE:
 0.5 - 6mm ±0.1mm 6 - 30mm ±0.2mm 30 - 120mm ±0.3mm ANGLES ±1°

NOTICE - These drawings, specifications, or other data (1) are, and remain the property of Amphenol corp. (2) must be returned upon request; and (3) are confidential and not to be disclosed to any person other than those to whom they are given by Amphenol Corp. The furnishing of these drawings, specifications, or other data by Amphenol Corp., or to any other person for any purpose is not to be regarded by implication or otherwise in any manner licensing, granting rights to permitting such holder or any other person to manufacture, use or sell any product, process or design, patented or otherwise, that may in any way be related to or disclosed by said drawings, specifications, or other data.

MATERIAL	DRAWN K.LI	DATE 07-Jul-09	TITLE TYPE 'N' PLUG PANEL MOUNT 4-HOLE FLANGE		Amphenol RF Danbury CT USA, Tainan, Taiwan, Shenzhen, China www.amphenolrf.com	
REFERENCE	ENGINEER G.WANG	DATE 24-Apr-07				
FINISH	APPROVED S.HSIEH	DATE 07-Jul-09	SCALE: 4.0:1.0	SHEET 2 OF 2	DRAWING NO. NI551E1-005-AT50GA-50	
	CAD FILE I:\N\NI551E1-005-AT50GA-50		DWG SIZE B	CODE ID 74868	REV C	ITEM NO. 031551AAR02AL5F
						PART NO. 82-6410