

NOTES:

1. MATERIALS AND FINISHES:

- BODY - BRASS, GOLD PLATING (.00000008 m [.000003 in] MIN THICK)
OVER NICKEL (.00000500 m [.000196 in] MIN THICK)
- CONTACT 1 - BeB, GOLD PLATING (.00000002 m [.000008 in] MIN THICK)
OVER NICKEL (.00000500 m [.000196 in] MIN THICK)
- CONTACT 2 - PB, GOLD PLATING (.00000002 m [.000008 in] MIN THICK)
OVER NICKEL (.00000500 m [.000196 in] MIN THICK)
- INSULATOR - PA9T, BLACK
- CAP - PA9T, BLACK

2. PACKAGING:

- TAPE AND REEL
- 700 PCS PER REEL
- 330 DIAMETER REEL

902-9024		REVISIONS			
DRAWING NO.	REV	DESCRIPTION	DATE	ECO	APPR
THIRD ANGLE PROJ.	A	RELEASE TO MFG.	6/22/06	46040	MAH

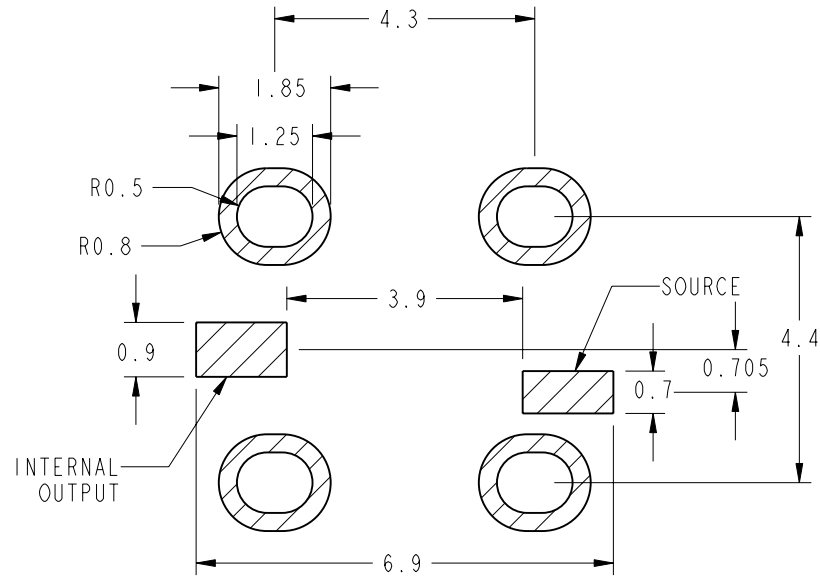

RECOMMENDED PCB LAYOUT

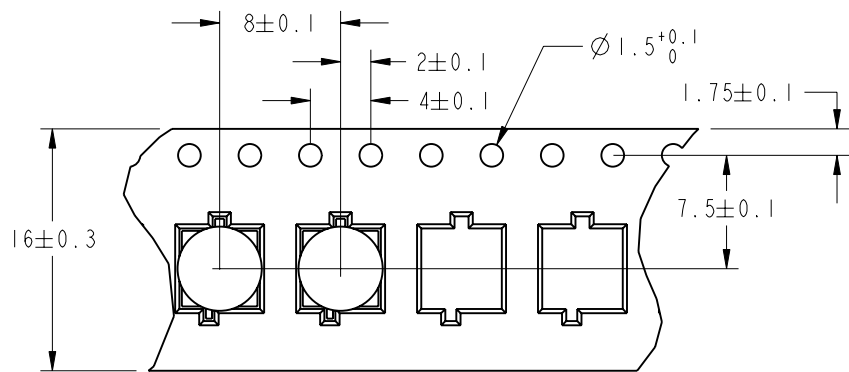

TAPE AND REEL PACKAGING

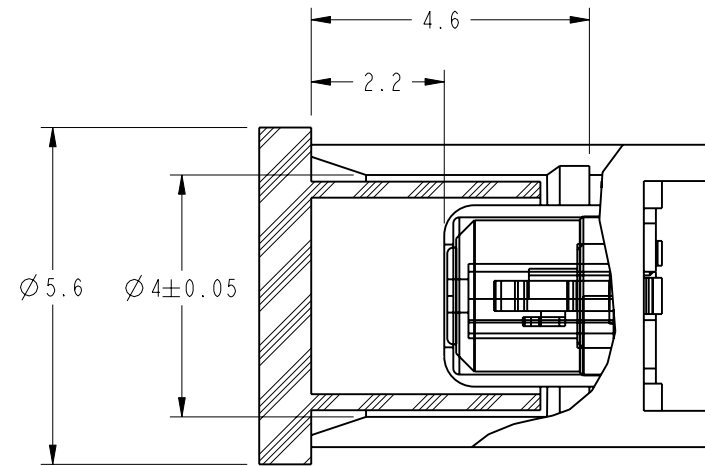
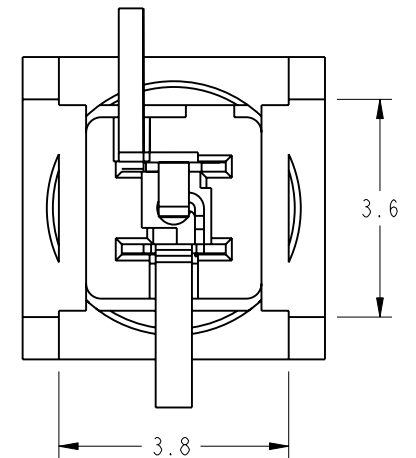
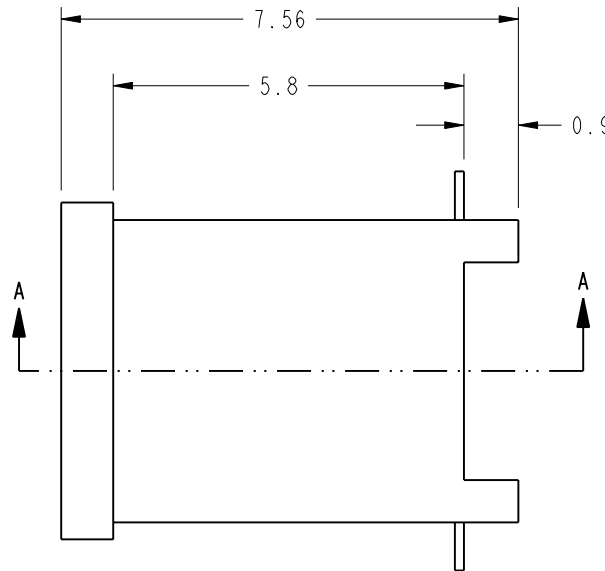
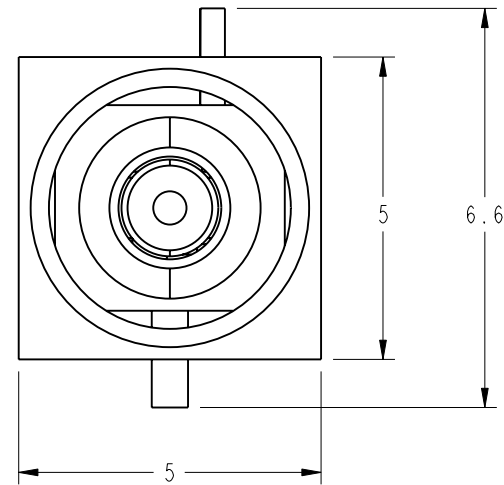

SECTION A-A

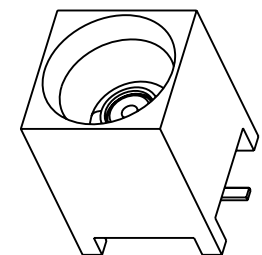

SCALE 4.000

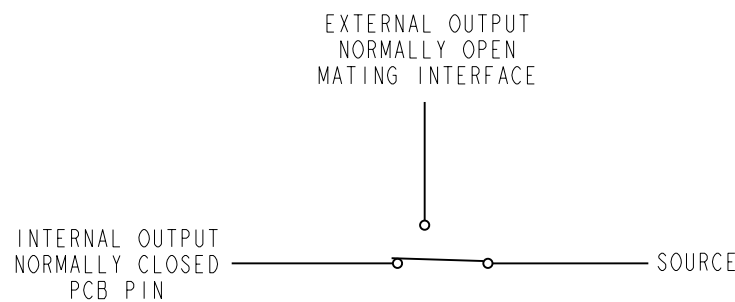

SINGLE POLE DOUBLE THROW SWITCH

METRIC DRAWING

CUSTOMER OUTLINE DRAWING

ALL OTHER SHEETS ARE FOR INTERNAL USE ONLY

UNLESS OTHERWISE SPECIFIED, DIMENSIONS ARE METRIC AND TOLERANCES ARE: 1 PLACE DECIMAL ± 0.3MM (.012") 2 PLACE DECIMAL ± .10 MM (.004") ANGLES ± 1°	MATERIAL	DRAWN M. HOYACK	DATE 15-Jun-06	TITLE RF SWITCH, JACK PCB SURFACE MOUNT		Amphenol RF Danbury, CT, USA Tainan, Taiwan Shenzhen, China www.amphenolrf.com	
	REFERENCE EAR #2019	ENGINEER M. HOYACK	DATE 15-Jun-06				
NOTICE - These drawings, specifications, or other data (1) are, and remain the property of Amphenol corp. (2) must be returned upon request; and (3) are confidential and not to be disclosed to any person other than those to whom they are given by Amphenol Corp. the furnishing of these drawings, specifications, or other data by Amphenol Corp., or to any other person to anyone for any purpose is not to be regarded by implication or otherwise in any manner licensing, granting rights to permitting such holder or any other person to manufacture, use or sell any product, process or design, patented or otherwise, that may in any way be related to or disclosed by said drawings, specifications, or other data.	CONFIGURATION LEVEL: Released	CAD FILE Root Folder/Switch/902-9024	CODE ID 74868	DWG SIZE B	DRAWING NO. 902-9024	SCALE: 8.0:1.0	SHEET 1 OF 2