

NOTES:

- MATERIALS AND FINISHES:
 BODY, CLAMP NUT, WASHERS,
 SHELL & RETAINING RING - BRASS, SILVER PLATING
 INSULATORS - PTFE, NATURAL
 CONTACT - BRASS, GOLD PLATING
 GASKETS - SILICONE RUBBER, RED

- MECHANICAL:
 A. TEMPERATURE RANGE: -65° C TO 165° C

- PACKAGING:
 A. QUANTITY: SINGLE PACK
 B. MARKING: BAG TO BE MARKED
 "AMPHENOL, PART NO. [SEE TABLE], AND DATE CODE"

4. SHOWS CABLE ENTRY DIMENSIONS.

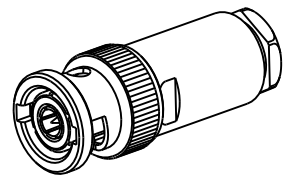

31-4774-3
SCALE 1.000

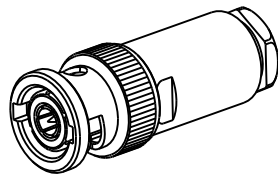

31-4774-5
SCALE 1.000

31-4774-3

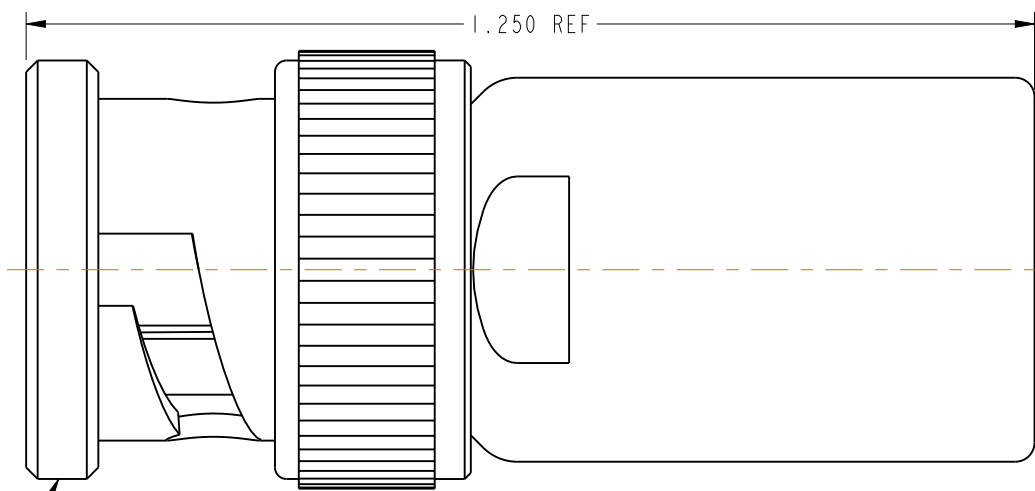

STAMP "AMPHENOL 31-4774-3"

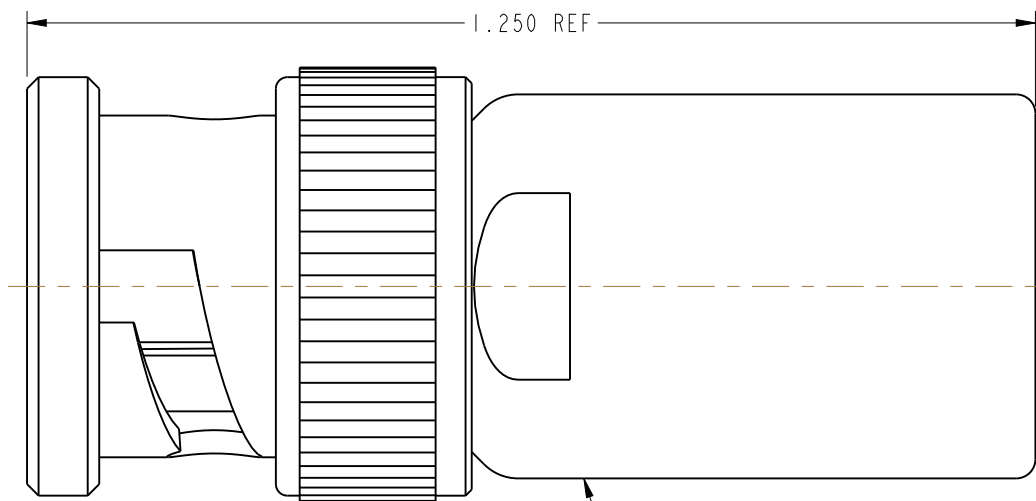

STAMP:
 LINE 1 = "74868 11438334
 LINE 2 = YYWW 31-4774-5"

31-4774-5

THIRD ANGLE PROJ.

REVISIONS

REV	DESCRIPTION	DATE	ECO	APPR
--	RELEASE TO MFG	--	--	--
AL	REDRAWN IN PRO-E & COD ADDED	1/17/14	49825	CL

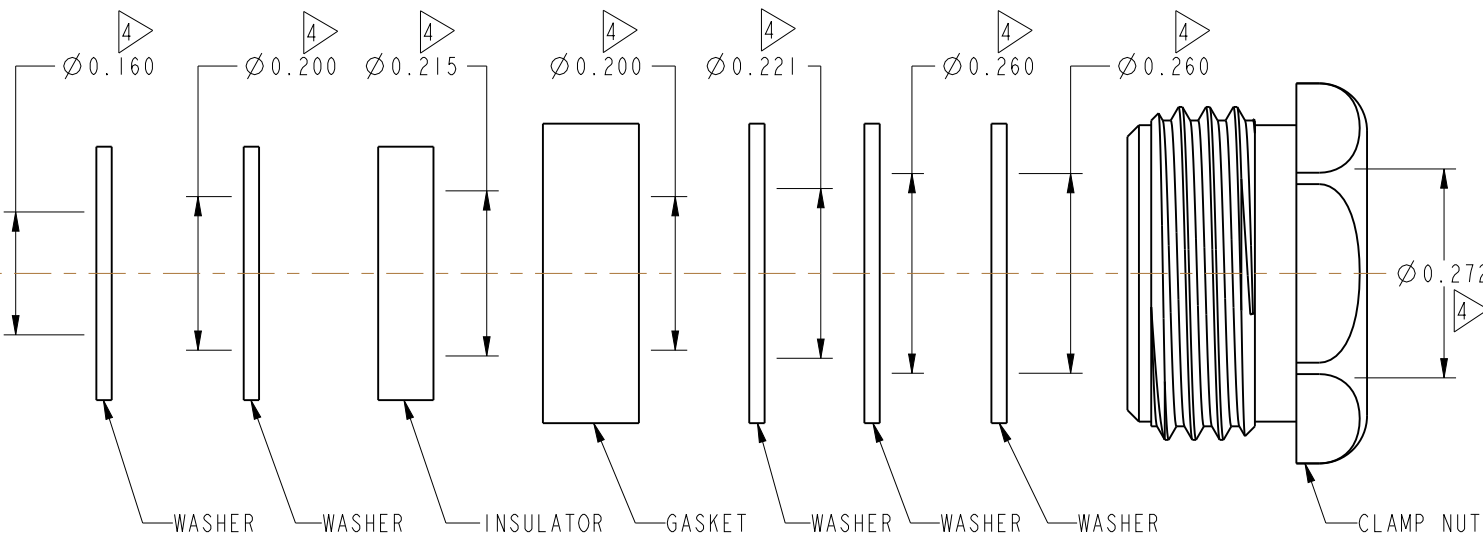
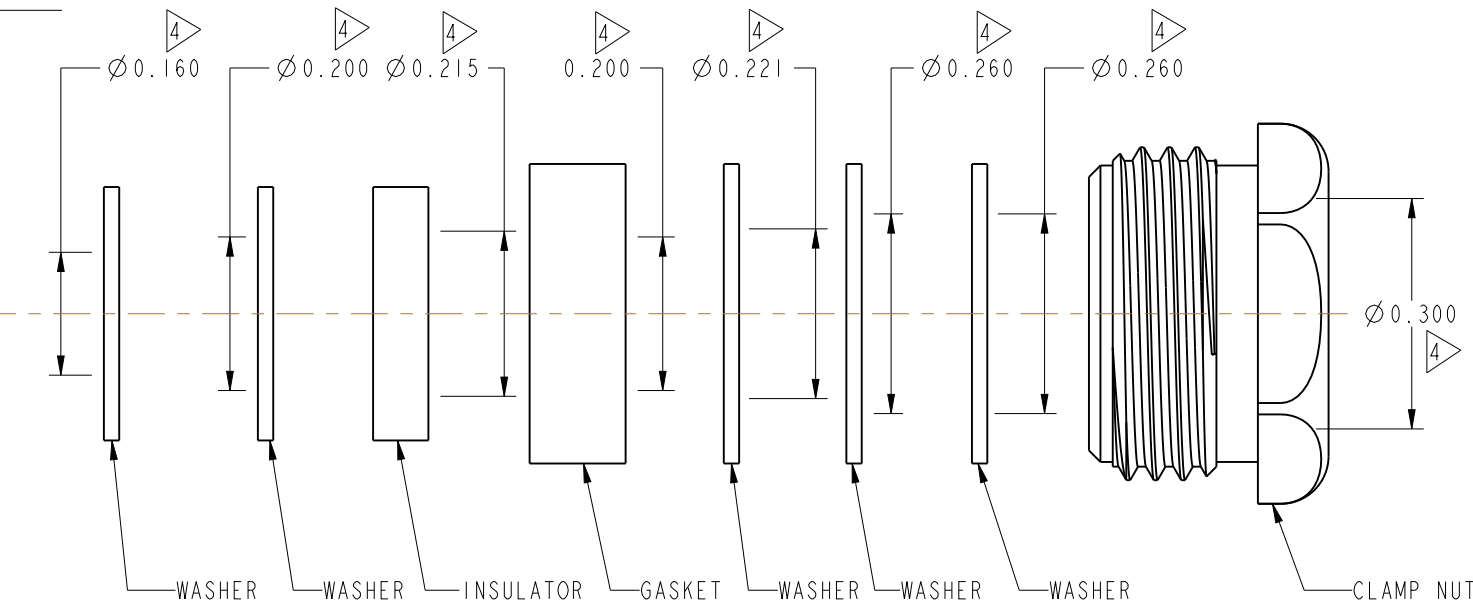

CUSTOMER OUTLINE DRAWING

ALL OTHER SHEETS ARE FOR INTERNAL USE ONLY

ITEM NO.	PART NO.	ASSEMBLED LENGTH	CABLE
31-4774-3	31-4774-3	1.432 REF.	RG-307 A/U
31-4774-5	31-4774-5	1.432 REF.	RG-307 A/U

UNLESS OTHERWISE SPECIFIED, DIMENSIONS ARE IN INCHES AND TOLERANCES ARE:
 2 PLACE DECIMAL 3 PLACE DECIMAL ANGLES
 ±.015 (0,381 mm) ±.005 (0,127 mm) ± 1°

NOTICE - These drawings, specifications, or other data (1) are, and remain the property of Amphenol corp. (2) must be returned upon request; and (3) are confidential and not to be disclosed to any person other than those to whom they are given by Amphenol Corp. the furnishing of these drawings, specifications, or other data by Amphenol Corp., or to any other person to anyone for any purpose is not to be regarded by implication or otherwise in any manner licensing, granting rights to permitting such holder or any other person to manufacture, use or sell any product, process or design, patented or otherwise, that may in any way be related to or disclosed by said drawings, specifications, or other data.

MATERIAL SEE NOTES	DRAWN CLEMMENT	DATE 03-Dec-13
REFERENCE EAR #	ENGINEER	DATE
CONFIGURATION LEVEL: In Work	APPROVED K. CAPOZZI	DATE 1/17/14
FINISH	CAD FILE	

TITLE TRIAx PLUG	SCALE: 4.0:1.0	SHEET 3 OF 3
	DWG SIZE B	REV AL

Amphenol RF www.amphenolrf.com	
DRAWING NO. 31-4774-X	
ITEM NO. 31-4774-X	
PART NO. 31-4774-X	