

NOTES:

- MATERIALS AND FINISHES (PLATING THICKNESS IN MICROINCHES):
  - OUTER & INNER FERRULE - COPPER, BRIGHT ACID TIN (200 MIN THICK)
  - OUTER & INNER BODY - BeCu, GOLD PLATING (50 MIN THICK)
  - CONTACT - BeCu, GOLD PLATING (50 MIN THICK)
  - WASHER - PTFE
  - INSULATOR - PTFE

- PACKAGING:
  - A. QUANTITY: SINGLE PACK
  - B. MARKING: BAG TO BE MARKED "AMPHENOL, 902-5020-2, AND DATE CODE"

3 SHOWS CABLE ENTRY DIMENSIONS.

CONNECTOR ASSEMBLY PROCEDURE:

- STRIP CABLE AS SHOWN. SLIDE OUTER FERRULE (ITEM 1) WELL UP OVER OUTER JACKET PRIOR TO FOLDING BACK CABLE SHIELD.
- A. SLIDE TEFLON WASHER OVER INNER CONDUCTOR OF CABLE, FLUSH WITH INNER DIELECTRIC.  
B. CRIMP INNER CONTACT TO CENTER CONDUCTOR OF CABLE, USING AMPHENOL TOOL FRAME 227-944 WITH 227-954 DIE SET 'C' GROOVE (0.034 DIAMOND).
- SLIDE INNER FERRULE OVER OUTER CONDUCTOR AND 'INTERLAYER'.
- FLARE OUTER CONDUCTOR SLIGHTLY AND INSERT INNER CONTACT INTO INNER BODY TO A FIRM BUTT. OUTER CONDUCTOR MUST GO OUTSIDE BACK END OF INNER BODY. SLIDE INNER FERRULE FORWARD OVER BRAID AND BUTT SHOULDER OF INNER BODY. CRIMP FERRULE USING AMPHENOL TOOL FRAME 227-944 WITH 227-954 DIE SET 'B' GROOVE (0.178 HEX).
- ASSEMBLE INNER BODY INTO OUTER BODY TO A FIRM BUTT, FOLD CABLE SHIELD FORWARD OVER BODY. SLIDE OUTER FERRULE FORWARD OVER BRAID AND BUTT SHOULDER OF BODY. CRIMP FERRULE USING AMPHENOL TOOL FRAME 227-944 WITH 227-954 DIE SET 'A' GROOVE (0.263 HEX).

THIRD ANGLE PROJ.

REVISIONS

REV	DESCRIPTION	DATE	ECO	APPR
--	RELEASE TO MFG.	-----	-----	-----
J	REDRAWN IN PRO-E & ADDED COD	9/20/13	49679	MB

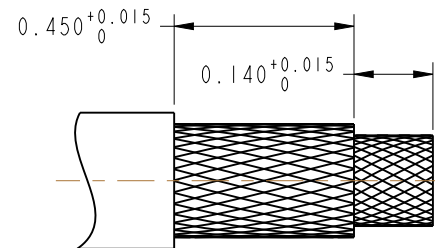

**STEP 1**  
CABLE PER ST5M1323  
(TIMES AA2325)

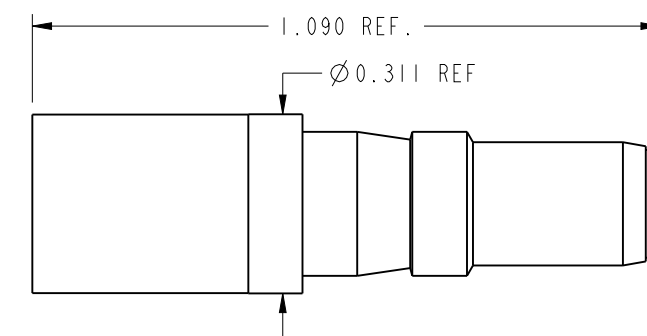
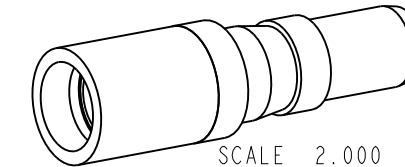
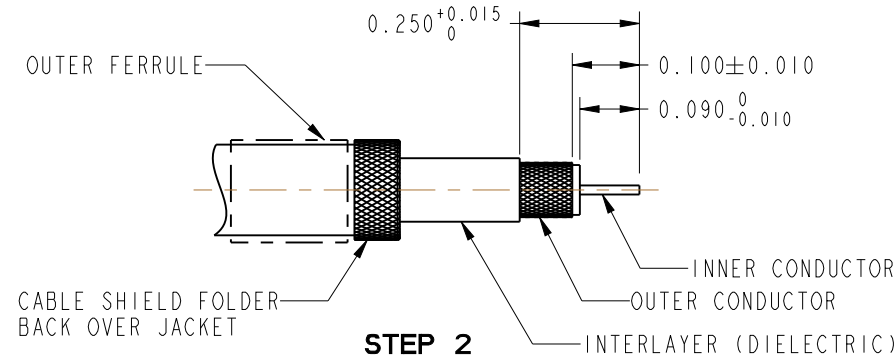

AFTER ASSEMBLY DIMENSIONS  
SCALE 3.000

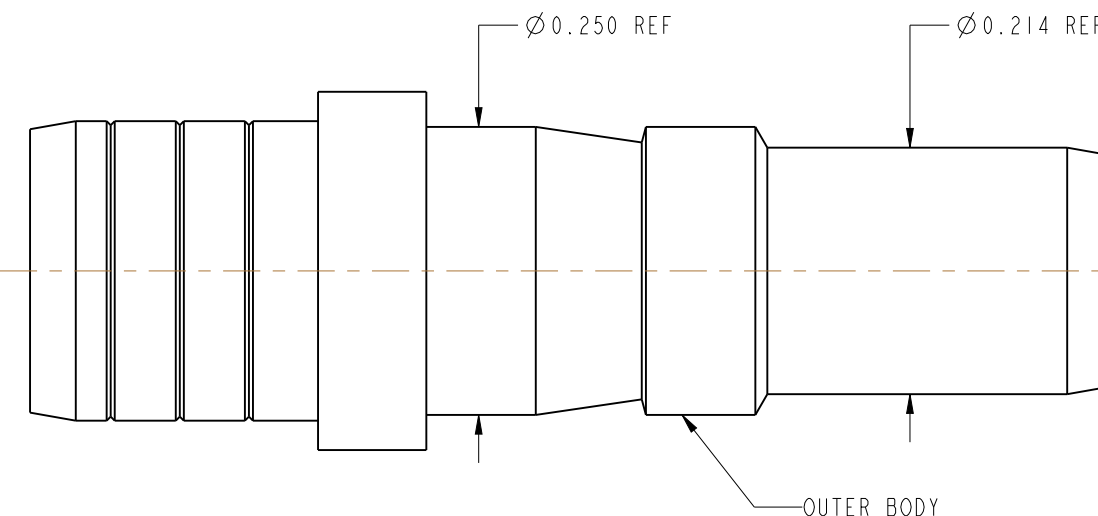
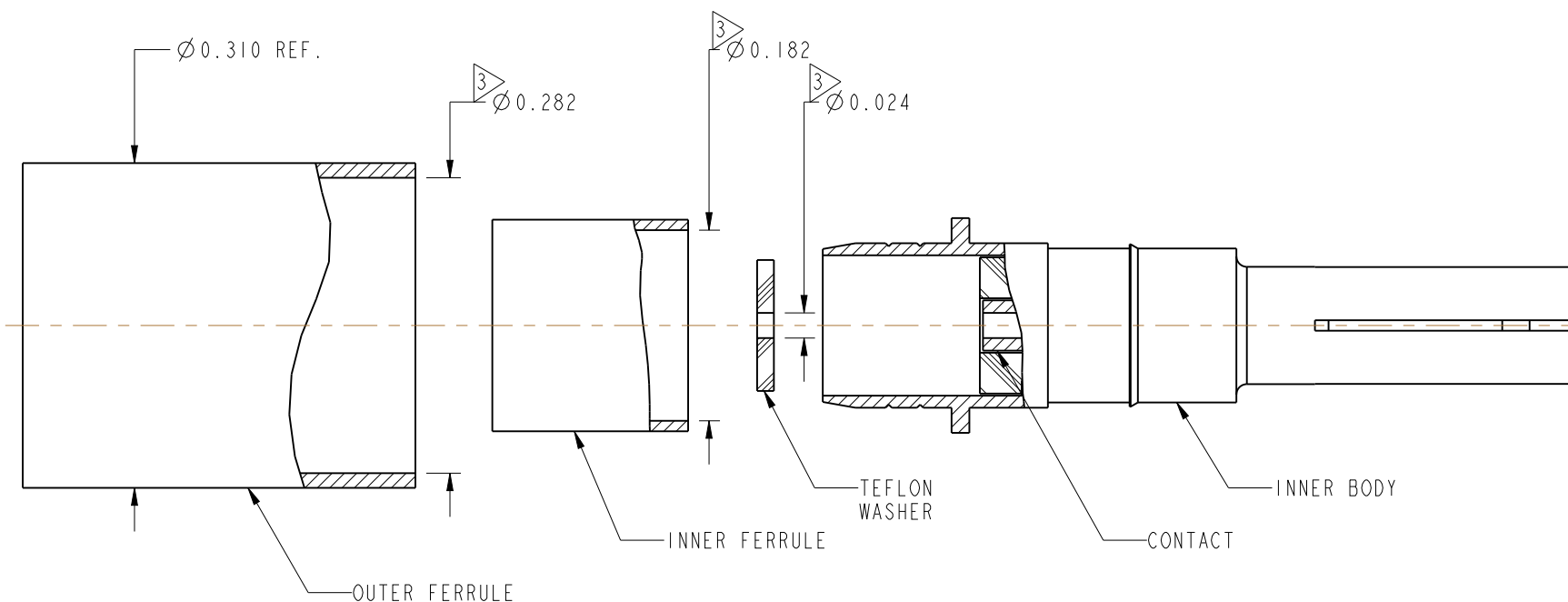

**CUSTOMER OUTLINE DRAWING**

ALL OTHER SHEETS ARE FOR INTERNAL USE ONLY

UNLESS OTHERWISE SPECIFIED, DIMENSIONS ARE IN INCHES AND TOLERANCES ARE: 2 PLACE DECIMAL ±.015 (0,381 mm) 3 PLACE DECIMAL ±.005 (0,127 mm) ANGLES ± 1°	MATERIAL	DRAWN	DATE	TITLE PLUG TRIAX FOR TIMES AA2325 CABLE SCALE: 6.0:1.0 SHEET 2 OF 2		Amphenol RF www.amphenolrf.com	
	SEE NOTES	MOHAN	08-Aug-13				
NOTICE - These drawings, specifications, or other data (1) are, and remain the property of Amphenol corp. (2) must be returned upon request; and (3) are confidential and not to be disclosed to any person other than those to whom they are given by Amphenol Corp. the furnishing of these drawings, specifications, or other data by Amphenol Corp., or to any other person to anyone for any purpose is not to be regarded by implication or otherwise in any manner licensing, granting rights to permitting such holder or any other person to manufacture, use or sell any product, process or design, patented or otherwise, that may in any way be related to or disclosed by said drawings, specifications, or other data.	REFERENCE	ENGINEER	DATE	DRAWING NO. 902-5020-2 ITEM NO. 902-5020-2		PART NO. 902-5020-2	
	DOR 21-902-315567, ST5M 1289, ST5M 132, ST5M 1290-001P REV H	F. HULL	14-Nov-91				
	FINISH	APPROVED	DATE	DWG SIZE B		REV J	
		K. CAPOZZI	8/28/13				