

Multilayer Varistor for ESD pulse [DC voltage lines/High speed signal lines]

Series : **EZJZ, EZJP**

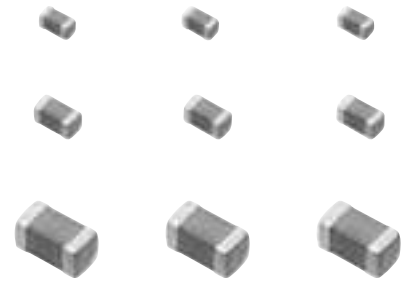

■ Features

- Excellent ESD suppression due to advanced material technology
- Meets IEC61000-4-2, Level 4 standard
- Can replace 2 Zener Diodes and 1 Capacitor
- Low capacitance versions for DC voltage lines of high speed busses
- Ultra low capacitance for signal lines of high speed busses
- Ideal usage for USB 2.0, IEEE1394, and HDMI high speed data busses
- RoHS compliant

■ Packaging Methods, Handling Precautions

Please see Data Files

■ Explanation of Part Numbers

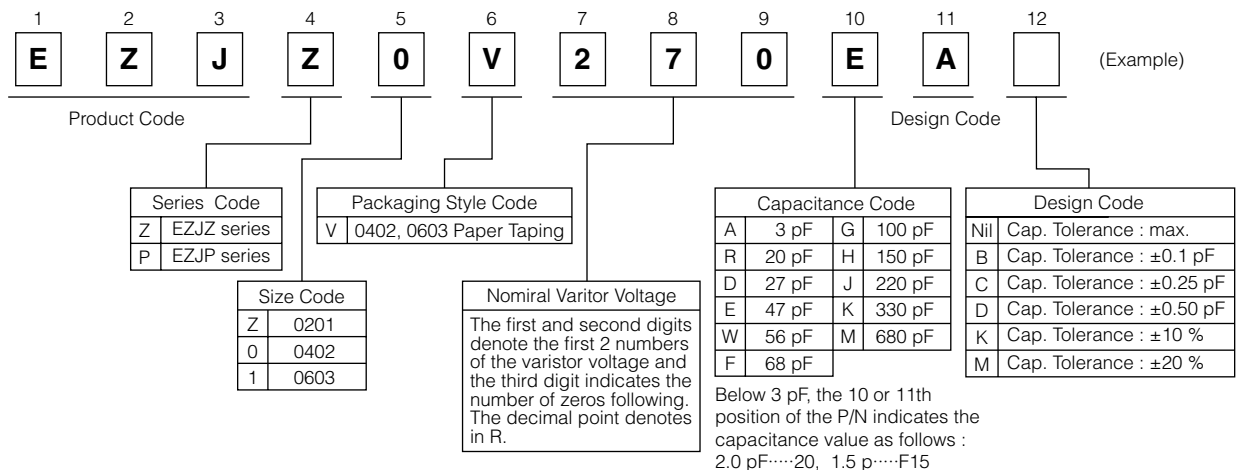

■ Construction

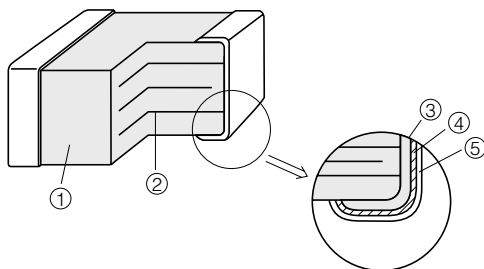

No.	Name
①	Semiconductive Ceramics
②	Internal electrode
③	Substrate electrode
④	Terminal electrode
⑤	External electrode

■ Dimensions in mm (not to scale)

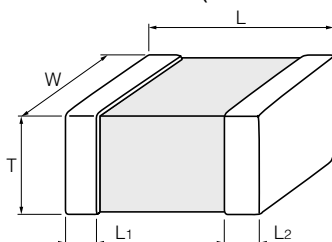

Size Code	Size(inch)	L	W	T	L ₁ , L ₂
Z	0201	0.60±0.03	0.30±0.03	0.30±0.03	0.15±0.05
0	0402	1.00±0.05	0.50±0.05	0.50±0.05	0.2±0.1
1	0603	1.6±0.1	0.8±0.1	0.8±0.1	0.3±0.2