

# VIKING PRODUCT MANUAL

COMMUNICATION &amp; SECURITY SOLUTIONS

## Add Keyless Entry and/or Card Reader Entry for a Single Door with Up to 250 Users

The **ES-1** is a door controller designed to operate a door strike or magnetic lock upon receiving a valid card read and/or keyless entry code from Wiegand devices. One **ES-1**, one or two Wiegand devices and a door strike or magnetic lock of your choice is required for each entry point.

The Wiegand device used may be the **Viking** model **PRX-1** Proximity Card Reader and/or the **PRX-2** Proximity Card Reader with Keypad, **PRX-3** Medium Range Proximity Card Reader or **PRX-4** Wiegand Output Keypad or any other card reader, RF transmitter or digital keypad that outputs the 26 bit Wiegand format. If two Wiegand devices are used, one can be placed on each side of a doorway to control access in both directions (entry and exit). Up to 250 valid Wiegand codes can be programmed into the **ES-1**.

Other programmable parameters, like relay activation, mode (normal, off, or open) and facility codes



are also stored in non-volatile memory. All programming is done with a local touch tone phone. Up to three **ES-1**s can be programmed simultaneously if they will be sharing all the same programming codes and parameters. Entry logging is possible with the **ES-1**'s log bus data output.

### Features

- Up to 250 tenants
- Program and control with a Touch Tone phone
- Use with any 26 bit Wiegand device
- Supports 1 entry point
- Compatible with Viking models **PRX-1**, **PRX-2**, **PRX-3**, and **PRX-4** and certain legacy 125KHz HID® proximity card readers\*
- Non-volatile memory (no batteries required)
- LOG BUS data output for logging entry events
- Card plus keypad mode for highest security
- One time codes for visitors
- Bi-directional (entry and exit) control

[www.vikingelectronics.com](http://www.vikingelectronics.com)

Information: (715) 386-8861

\* HID and the HID logo are registered trademarks of HID Global Corporation, an ASSA ABLOY company. All other trademarks are the property of their respective owners.

### Applications

- Business entrances
- High rise apartment buildings
- Condos
- Senior citizen buildings
- Assisted care centers
- Retirement homes
- Gated communities

### Specifications

**Power:** 120V AC/12V DC 500mA, UL listed adapter provided or use any 12-24V AC or DC source @ 100mA (designed to share power with the door strike's power supply)  
**Dimensions:** 133mm x 89mm x 44mm (5.25" x 3.5" x 1.75")

**Shipping Weight:** 1.3 kg (3 lbs)

**Environmental:** 0° C to 32° C (32° F to 90° F) with 5% to 95% non-condensing humidity

**Relay Contact Ratings:** 5A @ 30V DC/250V AC maximum

**Maximum Wiegand Length:** 152m (500 ft) - 24 AWG

**Maximum LOG BUS Length:** 1610m (5280 ft - 1 mile), 24 AWG

**Connections:** 11 screw terminals, (1) RJ-11 telco jack

## Definitions

**26 Bit Wiegand Format:** The industry standard data output of access control card readers.

**Bi-Directional Access:** Two Wiegand devices can be wired in parallel to one **ES-1** to control access in both directions at a single entry point. Simply place one card reader on each side of the door or gate. When either one detects a valid code, the **ES-1** will strike the door. Data logging will not be able to distinguish the direction of the access. If that is a requirement, two separate **ES-1s** will need to be installed, so each one can log separate access events from each side of the door.

**Card Plus Keypad Mode:** This is a higher security mode in which a valid card + a valid keypad entry is required to gain access.

**Entry Code:** The number that when it matches either a Keyless Entry or a Proximity Card number, allows access. Each tenant may have their own unique Entry Code that is easily changed or removed when a tenant moves out.

**Entry Point:** A door or gate allowing access into a secure or controlled area.

**Facility Code:** A 3-digit number that each proximity card contains in order to provide greater security. Usually the cards used at a given building all have the same facility code.

**Keyless Entry:** A way for tenants to let themselves in, by entering their entry code on a keypad.

**LOG BUS:** A two wire data bus that can be wired in parallel with additional **ES-1** log busses. Data is sent as 1200 baud ASCII characters at TTL levels (0-5 Volt). Any RS-232 port designed to receive TTL levels can receive log bus data directly on the "Receive Data" and "Signal Ground" pins.

**Memory Location:** The number used when programming, that stores the location of an entry code.

**One Time Code:** An entry code that can only be used once - this feature is handy for visitors. Once the code is used the **ES-1** forgets it.

**Proximity Card:** A credit size card that identifies itself when within close proximity of a reader. Card "swiping" is not necessary. The card contains a 3 digit Facility Code, a 5 digit Internal Card number and a 5 digit External Printed number, that may or may not match the Internal number.

**Proximity Card Reader:** A device used to read the data from a Proximity Card when its held within a few inches of the reader.

## Installation

**IMPORTANT:** Electronic devices are susceptible to lightning and power station electrical surges from both the AC outlet and the telephone line. It is recommended that a surge protector be installed to protect against such surges.

**\* Note:** Maximum Wiegand run length is 600 feet using 24 gauge wire when using the Viking model **PRX-1** proximity card reader, 500 feet for the **PRX-2** keypad/proximity card reader, 800 feet for the **PRX-3** (using 3 wire pairs for pwr) and 2000 feet for the **PRX-4** keypad. Run length is reduced to half if two share the same wire run from the same **C-4000** entry point. Run length will also be reduced if using a Wiegand device other than the Viking model **PRX-1**, that requires more than 35mA average operating current. Run lengths can be doubled by doubling up on the BLACK and RED 24 gauge wire, or using 21 gauge (or larger) wire. Certain electrically noisy locations might require shielded wire.

### A. Basic Wiring

A basic door access controlled entry point is wired as shown below. The relay can be connected as either Normally Open, or Normally Closed. All 26-bit Wiegand devices are fully supported (power and data) from the **ES-1** and can be installed up to 500 feet away using 24 gauge wire. Viking Wiegand devices can run even further (see **Note** above). The **ES-1** can support either a card reader (Viking model **PRX-1** or **PRX-3**), keyless entry keypad/proximity card reader (Viking model **PRX-2**) or a keyless entry keypad (Viking model **PRX-4**), or both. If both are installed, the "Card Plus Keypad" mode can be used. If any two Wiegand devices are used, one can be placed on each side of a doorway/gate for bi-directional (entry and exit) access control.

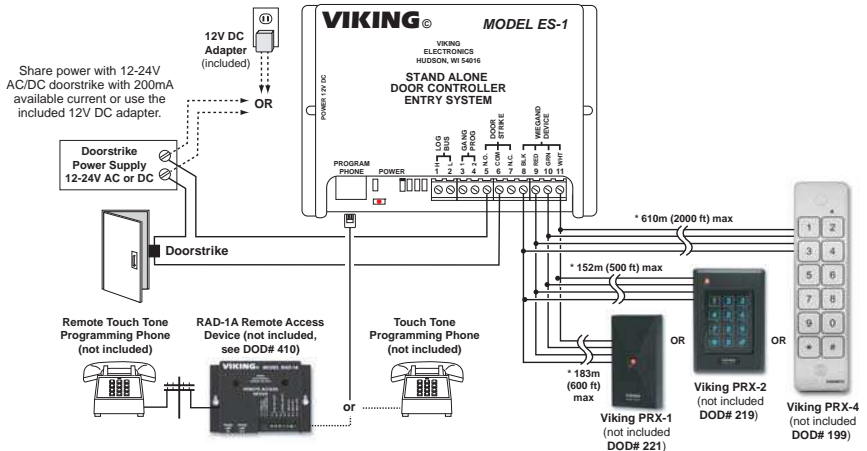

## B. Gang Programming Wiring

If multiple ES-1s are installed to handle door access control for multiple entry points, two or three of them can be programmed simultaneously if they are to be programmed identically. Do this by wiring **GANG PROG COMM** screw terminals 1 together, and screw terminals 2 together. The touch tone programming phone connected to any one of them will program all of them simultaneously.

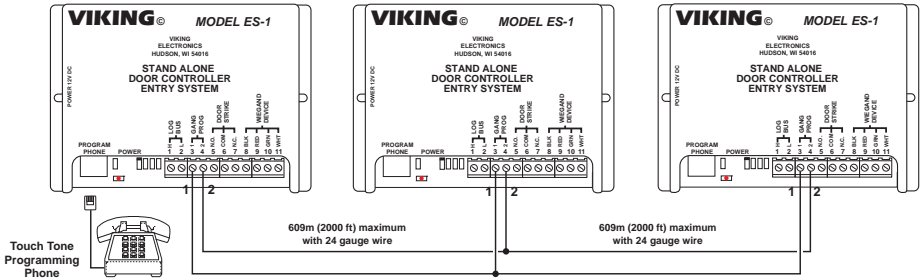

## C. LOG BUS

The ES-1 transmits 1200 baud ASCII data from the **LOG BUS** screw terminals. Log Bus data is sent each time Wiegand data is received from the entry point, and includes: an entry point ID number, if the entry was valid, non-valid, or off, the facility code, and the card number (or keypad entry code). The Log Bus can be daisy-chained by wiring the **LOG BUS** screw terminals L together and screw terminals H together as shown below.

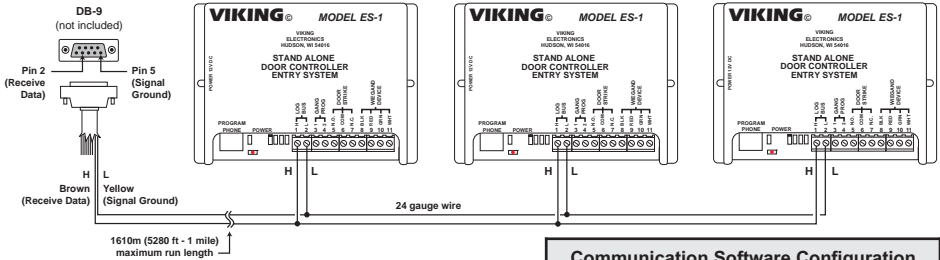

If the RS-232 input of a PC, printer, etc. is capable of receiving TTL level RS-232 signals, then the **LOG BUS** can be wired directly into the RS-232 "Receive Data" and "Signal Ground" pins to receive ASCII data. Windows "Hyper-Terminal" can be used to receive the data on a PC. Use the settings in the chart at the right:

Communication Software Configuration	
Com	Your serial port (1-4)
Baud rate	1200
Data Bits	8
Stop Bits	1
Parity	none
Flow Control	none

# Programming

## A. Accessing the Programming Mode

<b>Step 1.</b>	Connect a touch tone phone to the <b>PROGRAM PHONE</b> jack.
<b>Step 2.</b>	Come off-hook. A double beep will indicate that programming has been entered.
<b>Step 3.</b>	Program as shown in section B - 1.
<b>Step 4.</b>	To exit programming, simply hang up the phone.

## B. Tenant's Entry Codes

The ES-1 can be programmed with up to 250 tenant entry codes. A tenant can activate the door strike, keyless, from a Wiegand keypad or by using a proximity card with its 5 digit card number programmed as the entry code. When a given tenant moves out of the complex, the entry code for that tenant may be cleared without affecting any other tenant's entry code.

**Important:** 26-bit Wiegand data limits the entry code range from 00001 to 65535. Entry codes larger than 65535 will not work.

**WARNING:** If using a Viking model **PRX-4** keypad, do not program the ES-1 to accept entry code 65535 because that is the keypad's error code.

## 1. Programming a single Entry Code

While in programming, enter the tenant's 5 digit entry code + "#" + memory location number (001 - 250).

**Example: 12345 # 001**

## 2. Programming a continuous Bank of Entry Codes

If using the **PRX-4** keypad for keyless entry, it is an advantage, from a security standpoint, to have the entry codes all random numbers. On the contrary, if using the **PRX-1** card reader, proximity cards are typically purchased as a continuous bank of incrementing numbers. If this is the case, a large block of incrementing numbers can be programmed all at once. While in programming, enter the first (lowest value) 5 digit card number entry code + "#" + the starting memory location number (001 - 249). After two beeps are heard, enter **\*#** + the ending memory location (002 - 250).

**Example: 10300 # 001** (wait for two beeps) **\*# 150**

This will fill memory positions 001 through 150 sequentially with entry codes 10300 through 10450.

## 3. Programming One Time Entry Codes

An entry code that can only be used once, and is then forgotten by the **ES-1**, can be programmed similar to a single entry code or a bank of entry codes as shown above. An extra "**#**" before the "**#**" makes it a one time code.

**Example: 12345 \*# 001**

This will fill memory position 001 with one time entry code 12345.

**Example: 10300 \*# 001** (wait for two beeps) **\*# 150**

This will fill memory positions 001 through 150 sequentially with one time entry codes 10300 through 10450.

## 4. Deleting the Entry Code for One Memory Location

While in programming, enter "**#**" + memory location number (001 - 250) to clear.

## 5. Deleting all Entry Codes

While in programming, enter "**###**". This will clear all entry codes, all facility codes, and set all programming to factory settings.

**CAUTION: All entry codes will be permanently erased.**

## C. Operating Modes

The **ES-1** can be set into one of 3 different operating modes. The factory default setting is the **NORMAL** mode. In the **NORMAL** mode, the **ES-1** strikes the door when a proper card or keyless code is entered. Enter **\*1** to put the **ES-1** in **NORMAL** mode.

Enter **\*0** to put the **ES-1** in the **OFF** mode. In the **OFF** mode, the **ES-1** will not strike the door, even if a proper card or keyless code is entered.

Enter **\*2** to put the **ES-1** in the **OPEN** mode. In the **OPEN** mode, the **ES-1** continuously strikes the door. No card or keyless code is needed, and no **LOG BUS** data is sent.

**CAUTION: Some strikes are designed for intermittent operation only. The OPEN mode should NOT be used with these intermittent strikes, or damage to the strike may occur. Only use the OPEN mode with strikes designed for continuous operation.**

## D. Card Plus Keypad Mode

This is a mode in which a valid card, plus a valid keypad entry is required to gain access. Both a card reader (Viking model **PRX-1**) and a keypad (Viking model **PRX-4**) are required at the entry entry point. A higher level of security is achieved because acquiring someone's card is not enough to gain access. The number to be entered on the keypad must match the 5-digit internal card number. Because of this, it is important the actual 5-digit card number is not printed on the card itself.

While in programming, enter "**\*7**" to put the **ES-1** into the Card Plus Keypad mode, or enter "**\*8**" to remove the **ES-1** from this mode.

**Note: The cards can have a facility code of 001 to 254, but the keypad in use must have its facility code programmed to 255, so the ES-1 knows one from the other (see section E).**

## E. Facility Codes

A Wiegand type card reader can be added to the **ES-1** entry point for card access control. Twenty-six bit Wiegand access cards, such as Viking's model **PRX-C**, identify themselves with an 8-digit number. The first three digits are considered the Facility Code and the last five are the card number.

The **ES-1** shares the 5 digit entry code memory location for both keypad entry and card entry. In other words, the 5-digit card number is to be programmed as the tenant's entry code. Unless facility codes are programmed, the **ES-1** will only need to match the 5-digit card number with any programmed entry code to allow access.

For a higher level of security the 3-digit Facility Code should be programmed. Each **ES-1** can be programmed to accept up to 4 different Facility Codes.

**Note:** *If all 4 Facility Code locations are programmed to "000" (factory setting), the ES-1 will disregard the Facility Code all together, thus making access entry based only on the card number (or keypad entry) match with the programmed entry code.*

**Important:** *26-bit Wiegand data limits the facility code range from 001 to 255. A facility code larger than 255 will not be accepted.*

When in programming, enter the 3-digit Facility Code of the access cards being used, then "#" and the memory locations as follows:

Programming Facility Codes	Enter Digits	+ Location
First Facility Code (default = 0000) .....	3 digits (0-9)	+ #911
Second Facility Code (default = 0000) .....	3digits (0-9)	+ #912
Third Facility Code (default = 0000) .....	3digits (0-9)	+ #913
Fourth Facility Code (default = 0000) .....	3digits (0-9)	+ #914

## F. Entry Point ID Number

The **ES-1** outputs event data on the **LOG BUS** each time a card or keypad is used. An ID number can be programmed in each **ES-1** so that the device receiving the **LOG BUS** data knows which entry point the event came from. While in programming, enter a single digit ID number (1-9) + ##7.

**Example:** 6 ##7 = an Entry Point ID number of 6

## G. Relay Activation Time

The relay activation time can be programmed in seconds from 01 - 99. When in programming, enter the time in seconds + ##3 (00 = 1/2 second, factory set to 5 seconds).

**Example:** 05 ##3 = a 5 second relay activation time

## H. Beep Tones

While programming the **ES-1**, a double beep will be heard after entering a valid command or memory location. If an invalid command or number sequence is entered, it will be indicated by a triple beep. If an error is made, review the instructions and re-program that location. The **ES-1** is capable of detecting hardware memory errors and will output 4 beeps if there is a problem.

## I. Programming Features Quick Reference

Description	Enter Digits	+ Location
A single Entry Code .....	5 digits (0-9)	+ #001-250
A single one time use entry code .....	5 digits (0-9)	+ *#001-250
Continuous bank of entry codes.....	Enter first code, then #, then first location, then ##	+ last location
Clear one entry code .....	no digits	+ #001-250
Off mode .....	*0	
Normal Mode (factory setting).....	*1	
Open mode (only use with compatible strikes, see Programming, section C).....	*2	
Touch tone door strike activation .....	*6	
Card plus keypad mode enabled .....	*7	
Card plus keypad mode disabled (factory setting) .....	*8	#41
Entry point ID number (factory set to 1) .....	1 digit (00-01)	#7
Relay activation time (in seconds - factory set to 5 seconds) .....	2 digits (00-20)	+ #7
facility codes (all factory set to 000) .....	3 digits (00-99)	+ #911-914
Clear all entry codes and return all programming features back to factory settings ...	### (CAUTION: Erases all Programming!)	

## A. Tenant Card Reader Entry

A Wiegand device, such as the Viking **PRX-1** Proximity Card Reader (not included), is fully supported (power and data) by the **ES-1**. The **ES-1** entry controller monitors the Wiegand devices for 26 bit Wiegand data. When a card is read, the data is compared against the Facility Code (if used) and Entry Code data bases programmed in the **ES-1**, and access is granted if a match is found.

## B. Tenant Keyless Entry

A Wiegand device, such as the Viking **PRX-4** Wiegand Keypad (not included), is fully supported (power and data) by the **ES-1**. The **ES-1** entry controller monitors the Wiegand devices for 26 bit Wiegand data. When a keyless code is entered on the keypad, the data is compared against the Facility Code (if used) and Entry Code data base programmed in the **ES-1**, and access is granted if a match is found.

## C. Card Plus Keypad Entry

With both a Wiegand card reader and a Wiegand keypad wired to the same **ES-1**, either can be used to gain access. If the card plus keypad mode is enabled, first the card must match a programmed facility code and entry code, then the same 5-digit entry code must be entered on the keypad for access to be granted.

## D. Touch Tone Commands

In addition to using a Touch Tone phone to program the **ES-1**, a few Touch Tone commands are also available as follows:

Touch Tone Command	Description
*0	To put the <b>ES-1</b> in the <b>OFF</b> mode (no cards or keyless entry numbers grant access).
*1	To put the <b>ES-1</b> back in the <b>Normal</b> mode.
*2	To have the <b>ES-1</b> continuously strike the door/gate ( <b>*Open</b> mode), no <b>LOG BUS</b> data is sent
*6	To momentarily strike the <b>ES-1</b> . This allows someone within the building to allow a visitor in, even if the <b>ES-1</b> is in the <b>OFF</b> mode, no <b>LOG BUS</b> data is sent.

**\* Note:** Only use the **Open** mode with compatible strikes (see **Programming**, section C).

## E. One time Entry Codes

An entry code can be programmed for one time use. If this is the case, once the entry code has been used, it is instantly forgotten by the **ES-1**. This feature allows visitors limited access.

## F. Data Logging

Each time either a card is read or a keypad entry has been received, the **ES-1** will transmit 1200 baud ASCII data out of its **LOG BUS** screw terminals. Data sent includes: an entry point ID number (1-9), if the entry was valid (**V**), non-valid (**N**) or valid but access was not granted because the **ES-1** was in the **OFF** mode (**F**), the 3-digit facility code, and the card number (or keypad entry). An example of 3 different entry events is shown to the right. The **ES-1** outputs entry event data in real time, but does not time stamp.

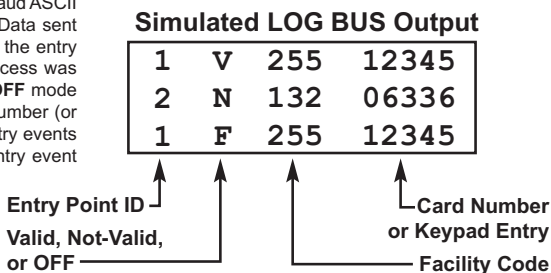

Visit [www.vikingelectronics.com](http://www.vikingelectronics.com) to download free **ENTRY LOGGER** software. The software provides transaction logging for the **ES-1** and **C-4000** Entry Controller systems. Compatible with any Windows based PC running Windows 95 or higher, the software adds time and date stamps to each transaction, and allows user printing, record saving, and complete search capabilities.



## Access Card Facility Codes

Memory Location	Facility Code
911	
912	
913	
914	

## ID Number

Memory Location	1-Digit ID Number
##7	

## Relay Activation Time

Memory Location	Time in Seconds
##3	

## Warranty

**IF YOU HAVE A PROBLEM WITH A VIKING PRODUCT, CONTACT: VIKING TECHNICAL SUPPORT AT (715) 386-8666**

Our Technical Support Department is available for assistance Monday 8am - 4pm and Tuesday through Friday 8am - 5pm central time. So that we can give you better service, before you call please:

1. Know the model number, the serial number and what software version you have (see serial label).
2. Have your Technical Practice in front of you.
3. It is best if you are on site.

### RETURNING PRODUCT FOR REPAIR

The following procedure is for equipment that needs repair:

1. Customer must contact Viking's Technical Support Department at 715-386-8666 to obtain a Return Authorization (RA) number. The customer MUST have a complete description of the problem, with all pertinent information regarding the defect, such as options set, conditions, symptoms, methods to duplicate problem, frequency of failure, etc.
2. Packing: Return equipment in original box or in proper packing so that damage will not occur while in transit. Static sensitive equipment such as a circuit board should be in an anti-static bag, sandwiched between foam and individually boxed. All equipment should be wrapped to avoid packing material lodging in or sticking to the equipment. Include ALL parts of the equipment. C.O.D. or freight collect shipments cannot be accepted. Ship cartons prepaid to: **Viking Electronics, 1531 Industrial Street, Hudson, WI 54016**
3. Return shipping address: Be sure to include your return shipping address inside the box. We cannot ship to a PO Box.
4. RA number on carton: In large printing, write the R.A. number on the outside of each carton being returned.

### RETURNING PRODUCT FOR EXCHANGE

The following procedure is for equipment that has failed out-of-box (within 10 days of purchase):

1. Customer must contact Viking's Technical Support at 715-386-8666 to determine possible causes for the problem. The customer MUST be able to step through recommended tests for diagnosis.
2. If the Technical Support Product Specialist determines that the equipment is defective based on the customer's input and troubleshooting, a Return Authorization (R.A.) number will be issued. This number is valid for fourteen (14) calendar days from the date of issue.
3. After obtaining the R.A. number, return the approved equipment to your distributor, referencing the R.A. number. Your distributor will then replace the Viking product using the same R.A. number.
4. **The distributor will NOT exchange this product without first obtaining the R.A. number from you. If you haven't followed the steps listed in 1, 2 and 3, be aware that you will have to pay a restocking charge.**

## TWO YEAR LIMITED WARRANTY

Viking warrants its products to be free from defects in the workmanship or materials, under normal use and service, for a period of two years from the date of purchase from any authorized Viking distributor. If at any time during the warranty period, the product is deemed defective or malfunctions, return the product to Viking Electronics, Inc., 1531 Industrial Street, Hudson, WI., 54016. Customer must contact Viking's Technical Support Department at 715-386-8666 to obtain a Return Authorization (R.A.) number.

This warranty does not cover any damage to the product due to lightning, over voltage, under voltage, accident, misuse, abuse, negligence or any damage caused by use of the product by the purchaser or others. This warranty does not cover non-EWP products that have been exposed to wet or corrosive environments. This warranty does not cover stainless steel surfaces that have not been properly maintained.

**NO OTHER WARRANTIES. VIKING MAKES NO WARRANTIES RELATING TO ITS PRODUCTS OTHER THAN AS DESCRIBED ABOVE AND DISCLAIMS ANY EXPRESS OR IMPLIED WARRANTIES OR MERCHANTABILITY OR FITNESS FOR ANY PARTICULAR PURPOSE.**

**EXCLUSION OF CONSEQUENTIAL DAMAGES. VIKING SHALL NOT, UNDER ANY CIRCUMSTANCES, BE LIABLE TO PURCHASER, OR ANY OTHER PARTY, FOR CONSEQUENTIAL, INCIDENTAL, SPECIAL OR EXEMPLARY DAMAGES ARISING OUT OF OR RELATED TO THE SALE OR USE OF THE PRODUCT SOLD HEREUNDER.**

**EXCLUSIVE REMEDY AND LIMITATION OF LIABILITY. WHETHER IN AN ACTION BASED ON CONTRACT, TORT (INCLUDING NEGLIGENCE OR STRICT LIABILITY) OR ANY OTHER LEGAL THEORY, ANY LIABILITY OF VIKING SHALL BE LIMITED TO REPAIR OR REPLACEMENT OF THE PRODUCT, OR AT VIKING'S OPTION, REFUND OF THE PURCHASE PRICE AS THE EXCLUSIVE REMEDY AND ANY LIABILITY OF VIKING SHALL BE SO LIMITED.**

**IT IS EXPRESSLY UNDERSTOOD AND AGREED THAT EACH AND EVERY PROVISION OF THIS AGREEMENT WHICH PROVIDES FOR DISCLAIMER OF WARRANTIES, EXCLUSION OF CONSEQUENTIAL DAMAGES, AND EXCLUSIVE REMEDY AND LIMITATION OF LIABILITY, ARE SEVERABLE FROM ANY OTHER PROVISION AND EACH PROVISION IS A SEPARABLE AND INDEPENDENT ELEMENT OF RISK ALLOCATION AND IS INTENDED TO BE ENFORCED AS SUCH.**

**Product Support: (715) 386-8666**

Due to the dynamic nature of the product design, the information contained in this document is subject to change without notice. Viking Electronics, and its affiliates and/or subsidiaries assume no responsibility for errors and omissions contained in this information. Revisions of this document or new editions of it may be issued to incorporate such changes.