

Control 1 to 9 Relays Remotely



The **RC-3** enables a standard Touch Tone phone to control up to 3 maintained ON, maintained OFF, or momentary relay contacts from a remote location. The **RC-3** is fully user programmable and uses non-volatile E² memory.

Up to three **RC-3**'s can be daisy chained on the same line to control up to nine relays.

The **RC-3** features switchable 32V talk battery allowing easy installation on a trunk port. In addition, the unit can be connected directly to a C.O. line or analog PABX/KSU station.

Features

- Operational commands can be customized 1, 2 or 3 digits in length
- User Touch Tone programmable
- Non-volatile E² memory
- 6 digit security code (to access programming)
- 1-6 digit access code (disable or enable for additional control security)
- Switchable 32V talk battery
- Relay interrogation tones
- Programmable relay timed closures
- Cascade up to three RC-3's to control up to nine relays
- Programmable ring delay before answering
- Status LED's for relays 1, 2, 3 and power
- One power adaptor can power up to three units

Applications

Remote Control of:

- High security building entry systems
- Door strikes and gates in conjunction with doorboxes (W-1000, etc.)
- Signs, lights, cameras, sprinklers, motors
- Other contact controlled equipment

info@vikingelectronics.com

<http://www.vikingelectronics.com>

Specifications

Power: 12-24V AC or DC, 120V AC/12V DC 500mA UL listed adapter provided

Shipping Weight: 0.54 kg (1.2 lbs)

Dimensions: 133mm x 89mm x 44mm (5.25" x 3.5" x 1.75")

Environmental: 0°C to 32°C (32°F to 90°F) with 5% to 95% non-condensing humidity

Talk Battery Output: 32V DC

Relay contact ratings: 5A @ 30VDC / 250VAC (relay 1), 0.5A @ 125VAC / 1A @ 30VDC (relays 2 and 3)

Connections: (1) 6 position screw terminal strip, (1) 9 position screw terminal strip

IF YOU HAVE A PROBLEM WITH A VIKING PRODUCT, PLEASE CONTACT: VIKING TECHNICAL SUPPORT AT (715) 386-8666

Our Technical Support Department is available for assistance Monday 8am - 4pm and Tuesday through Friday 8am - 5pm central time. So that we can give you better service, before you call please:

1. Know the model number, the serial number and what software version you have (see serial label).
2. Have your Technical Practice in front of you.
3. It is best if you are on site.

RETURNING PRODUCT FOR REPAIR

The following procedure is for equipment that needs repair:

1. Customer must contact Viking's Technical Support Department at 715-386-8666 to obtain a Return Authorization (RA) number. The customer MUST have a complete description of the problem, with all pertinent information regarding the defect, such as options set, conditions, symptoms, methods to duplicate problem, frequency of failure, etc.
2. Packing: Return equipment in original box or in proper packing so that damage will not occur while in transit. Static sensitive equipment such as a circuit board should be in an anti-static bag, sandwiched between foam and individually boxed. All equipment should be wrapped to avoid packing material lodging in or sticking to the equipment. Include ALL parts of the equipment. C.O.D. or freight collect shipments cannot be accepted. Ship cartons prepaid to:
Viking Electronics, 1531 Industrial Street, Hudson, WI 54016
3. Return shipping address: Be sure to include your return shipping address inside the box. We cannot ship to a PO Box.
4. RA number on carton: In large printing, write the R.A. number on the outside of each carton being returned.

RETURNING PRODUCT FOR EXCHANGE

The following procedure is for equipment that has failed out-of-box (within 10 days of purchase):

1. Customer must contact Viking's Technical Support at 715-386-8666 to determine possible causes for the problem. The customer MUST be able to step through recommended tests for diagnosis.
2. If the Technical Support Product Specialist determines that the equipment is defective based on the customer's input and troubleshooting, a Return Authorization (R.A.) number will be issued. This number is valid for fourteen (14) calendar days from the date of issue.
3. After obtaining the R.A. number, return the approved equipment to your distributor, referencing the R.A. number. Your distributor will then replace the product over the counter at no charge. The distributor will then return the product to Viking using the same R.A. number.
4. **The distributor will NOT exchange this product without first obtaining the R.A. number from you. If you haven't followed the steps listed in 1, 2 and 3, be aware that you will have to pay a restocking charge.**

LIMITED WARRANTY

Viking warrants its products to be free from defects in the workmanship or materials, under normal use and service, for a period of one year from the date of purchase from any authorized Viking distributor or 18 months from the date manufactured, whichever ever is greater. If at any time during the warranty period, the product is deemed defective or malfunctions, return the product to Viking Electronics, Inc., 1531 Industrial Street, Hudson, WI., 54016. Customer must contact Viking's Technical Support Department at 715-386-8666 to obtain a Return Authorization (R.A.) number.

This warranty does not cover any damage to the product due to lightning, over voltage, accident, misuse, abuse, negligence or any damage caused by use of the product by the purchaser or others. This warranty does not cover non-EWP products that have been exposed to wet or corrosive environments.

NO OTHER WARRANTIES. VIKING MAKES NO WARRANTIES RELATING TO ITS PRODUCTS OTHER THAN AS DESCRIBED ABOVE AND DISCLAIMS ANY EXPRESS OR IMPLIED WARRANTIES OR MERCHANTABILITY OR FITNESS FOR ANY PARTICULAR PURPOSE.

EXCLUSION OF CONSEQUENTIAL DAMAGES. VIKING SHALL NOT, UNDER ANY CIRCUMSTANCES, BE LIABLE TO PURCHASER, OR ANY OTHER PARTY, FOR CONSEQUENTIAL, INCIDENTAL, SPECIAL OR EXEMPLARY DAMAGES ARISING OUT OF OR RELATED TO THE SALE OR USE OF THE PRODUCT SOLD HEREUNDER.

EXCLUSIVE REMEDY AND LIMITATION OF LIABILITY. WHETHER IN AN ACTION BASED ON CONTRACT, TORT (INCLUDING NEGLIGENCE OR STRICT LIABILITY) OR ANY OTHER LEGAL THEORY, ANY LIABILITY OF VIKING SHALL BE LIMITED TO REPAIR OR REPLACEMENT OF THE PRODUCT, OR AT VIKING'S OPTION, REFUND OF THE PURCHASE PRICE AS THE EXCLUSIVE REMEDY AND ANY LIABILITY OF VIKING SHALL BE SO LIMITED.

IT IS EXPRESSLY UNDERSTOOD AND AGREED THAT EACH AND EVERY PROVISION OF THIS AGREEMENT WHICH PROVIDES FOR DISCLAIMER OF WARRANTIES, EXCLUSION OF CONSEQUENTIAL DAMAGES, AND EXCLUSIVE REMEDY AND LIMITATION OF LIABILITY, ARE SEVERABLE FROM ANY OTHER PROVISION AND EACH PROVISION IS A SEPARABLE AND INDEPENDENT ELEMENT OF RISK ALLOCATION AND IS INTENDED TO BE ENFORCED AS SUCH.

FCC REQUIREMENTS

This equipment complies with Part 68 of the FCC rules and the requirements adopted by the ACTA. Inside the front panel of this equipment is a label that contains, among other information, a product identifier in the format US:AAEQ##TXXXX. If requested, this number must be provided to the telephone company.

The REN is used to determine the number of devices that may be connected to a telephone line. Excessive REN's on a telephone line may result in the devices not ringing in response to an incoming call. In most but not all areas, the sum of the REN's should not exceed five (5.0). To be certain of the number of devices that may be connected to a line, as determined by the total REN's, contact the local telephone company. For products approved after July 23, 2001, the REN for this product is part of the product identifier that has the format US:AAEQ##TXXXX. The digits represented by ## are the REN without a decimal point (e.g., 03 is a REN of 0.3). For earlier products, the REN is separately shown on the label.

The plug used to connect this equipment to the premises wiring and telephone network must comply with the applicable FCC Part 68 rules and requirements adopted by the ACTA. If your home has specially wired alarm equipment connected to the telephone line, ensure the installation of this RC-3 does not disable your alarm equipment. If you have questions about what will disable alarm equipment, consult your telephone company or a qualified installer.

If the RC-3 causes harm to the telephone network, the telephone company will notify you in advance that temporary discontinuance of service may be required. But if advance notice isn't practical, the telephone company will notify the customer as soon as possible. Also, you will be advised of your right to file a complaint with the FCC if you believe it is necessary.

The telephone company may make changes in its facilities, equipment, operations, or procedures that could affect the operation of the equipment. If this happens, the telephone company will provide advance notice in order for you to make

the necessary modifications to maintain uninterrupted service.

If trouble is experienced with the RC-3, for repair or warranty information, please contact:

Viking Electronics, Inc., 1531 Industrial Street, Hudson, WI 54016 (715) 386-8666

If the equipment is causing harm to the telephone network, the telephone company may request that you disconnect the equipment until the problem is resolved.

Connection to Party Line Service is subject to State Tariffs. Contact the state public utility commission, public service commission or corporation commission for information.

WHEN PROGRAMMING EMERGENCY NUMBERS AND (OR) MAKING TEST CALLS TO EMERGENCY NUMBERS:

Remain on the line and briefly explain to the dispatcher the reason for the call. Perform such activities in the off-peak hours, such as early morning or late evenings.

It is recommended that the customer install an AC surge arrester in the AC outlet to which this device is connected. This is to avoid damaging the equipment caused by local lightning strikes and other electrical surges.

PART 15 LIMITATIONS

This equipment has been tested and found to comply with the limits for a Class A digital device, pursuant to Part 15 of the FCC Rules. These limits are designed to provide reasonable protection against harmful interference when the equipment is operated in a commercial environment. This equipment generates, uses, and can radiate radio frequency energy and, if not installed and used in accordance with the instruction manual, may cause harmful interference to radio communications. Operation of this equipment in a residential area is likely to cause harmful interference in which case the user will be required to correct the interference at his own expense.

Definitions

ACCESS CODE: The Access Code is a user programmable touch-tone code from 1 - 6 digits in length which can be used to access the **RC-3's** relays. If the **RC-3** is programmed to require an access code, it will not respond to relay commands until "*" plus the access code has been successfully entered. It is recommended that the default Access Code of 123456 be changed to a unique code by the user in programming. The requirement of "*" plus the access code is disabled by setting dip switch 2 to OFF.

ACCESS TIMER: The function of the Access Timer is to set the **RC-3** back to the Secure State if Relay Commands are no longer being entered. The access timer always applies when using the **RC-3** in the Ring Trip Connection (access code enabled or disabled) and the Parallel Connection but only when Access Code is enabled (dip switch 2 ON). The timer has a default value of 20 seconds and counts down in the background when the **RC-3** is in the Relay Control State. Every time a touch tone is entered, the Access Timer is reloaded, so it is possible to stay in the Relay Control State as long as touch tones are being entered. If the Access Timer elapses, it gives three beeps and sets the unit back to the Secure State. To return to the Relay Control State, it is necessary to reenter "*" plus the Access Code. The minimum programmable time for the Access Timer is 3 seconds.

E-30 MODE: The E-30 Mode is enabled by setting dip switch 4 to ON. This mode is used when using one or more Viking **E-30** or **E-30-EWP's** (handsfree speakerphone with dialer) on the same line with the **RC-3**. This mode changes the default relay commands in the **RC-3** to commands that do not conflict with the features or programming of the **E-30** speakerphones. When set to the **E-30** mode, custom relay commands can not be programmed (error beeps are provided). The **E-30** mode is compatible with the relay bank number programming, so it is possible to have three **RC-3's** and nine **E-30's** on the same line for nine entry phones and nine door or gate control relays.

INTERDIGIT TIMER: This timer operates in the Relay Control or Unsecure State and can be thought of as a "start over" timer. Its purpose is to allow the user to go back and start a Relay Command over if an error was made. In the normal entry of Relay Commands, as long as the time between touch tones does not reach three seconds, the Interdigit Timer does nothing. However, if a mistake is made, the user can just wait three seconds, hear a single beep and start the Relay Command entry over. The Interdigit Timer only applies when the **RC-3** is programmed with relay commands that are two or three digits in length. When programmed for single digit commands, there are no "incomplete" commands, so the single beep is not provided.

LOOP DETECTION: The **RC-3** includes hardware to provide loop detection. When a phone is connected to the OUT terminals of the **RC-3**, this tells the unit when the phone is in use, making it possible to both start and terminate the Relay Control State (if programmed).

NORMAL MODE: The RC-3 is running in the Normal Mode anytime dip switch 4 is set to off to disable the E-30 Mode. In the Normal Mode, default relay commands exist but custom relay and global commands of one, two or three digits in length can be programmed. When dip switch 2 is set to on, “*” plus a one to six digit access code must be dialed before relay commands can be entered.

PARALLEL CONNECTION: The Parallel Connection allows the RC-3 to be “parallel” connected to a phone line (or talk path) and detect touch tones to control relays, when the device using the line is not connected to the “Output” side of the RC-3. Ideally, the phone line or talk path is passed through the RC-3 from “In” to “Out”, so the RC-3 can use it’s Loop Detection to determine when the line is in use or goes back to idle. The Parallel Connection allows the RC-3 to function properly in the cases when it is not possible to wire all devices that share the line through the “In” and “Out” of the RC-3. To use the Parallel Connection, tap off the phone line or talk path and connect it to the “In” side of the RC-3 and set the Talk Battery switch to OFF.

PROGRAMMING TIMER: The Programming Timer is a 20-second timer that runs when remote programming is entered by calling into the RC-3. Every time a touch tone is entered, the timer is reloaded, so it is possible to stay in programming as long as at least one touch tone is entered every twenty seconds. If the timer elapses, the RC-3 gives three beeps and hangs up.

RELAY COMMANDS: These are user-programmable touch tone commands that tell the RC-3 to turn the relays on or off, start a timed closure, or indicate status. The default values for the Relay Commands are listed in the RC-3 Operation Commands section.

RELAY CONTROL STATE: The RC-3 is in the Relay Control State when access code is enabled (dip switch 2 ON) and “*” plus the correct Access Code has been entered. Once in this mode it will respond to Relay Commands. The RC-3 leaves the Relay Control State when the Access Timer elapses (Ring Trip Connection or Parallel Connection with Access Code enabled) or when the user hangs up in Trunk Connection or Series Connection. Similar to the Unsecure State but in the Unsecure State the Access Timer does not apply.

RING TRIP CONNECTION: In the Ring Trip Connection, the RC-3 is connected to a CO line or analog PABX/KSU station. Talk battery is provided by the CO or PABX, so the RC-3 talk battery switch should be turned OFF. The CO or PABX rings the RC-3, which answers after the programmed ring delay and can then provide relay closures.

SECURE STATE: When access code is enabled (dip switch 2 ON) and “*” plus the correct access code has not yet been entered, the RC-3 is in the Secure State. In this Secure State, the RC-3 ignores all other touch tone dialing except “*” plus a match to the Access Code to access the Relay Control State or “*” plus a match to the Security Code to access the programming mode.

SECURITY CODE: The Security Code is a six-digit touch tone code used to enter programming. Once the code has been successfully entered, any of the programmable features can be changed. It is recommended that the default Security Code of 845464 be changed to a unique code by the user in programming. See **Programming**.

SERIES CONNECTION: The Series Connection is when the phone line or talk path is passed through the RC-3 from “In” to “Out”. The RC-3 then uses it’s Loop Detection to determine when the line is in use or goes back to idle. Once the Relay Control State has been accessed, the user remains in the Relay Control State as long as the loop is still detected. The Access Timer and Programming Timer are not running in the Series Connection.

TRUNK CONNECTION: In the Trunk Connection, the RC-3 is connected to a trunk input of a phone system or phones dedicated for relay control. The RC-3 provides 32V of talk battery, and the unit is accessed by just going off hook on a connected phone or accessing the trunk input. The Access Timer and Programming Timer are not running in the Trunk Connection.

UNSECURE STATE: When the access code is disabled (dip switch 2 off), the RC-3 is in the Unsecure State. In this mode, the RC-3 continuously monitors touch tones and acts on any match to a relay command it detects, even if they are preceded by or followed by other touch tones. The Access Timer is not running in the Unsecure State.

Installation

A. Single RC-3 Installation

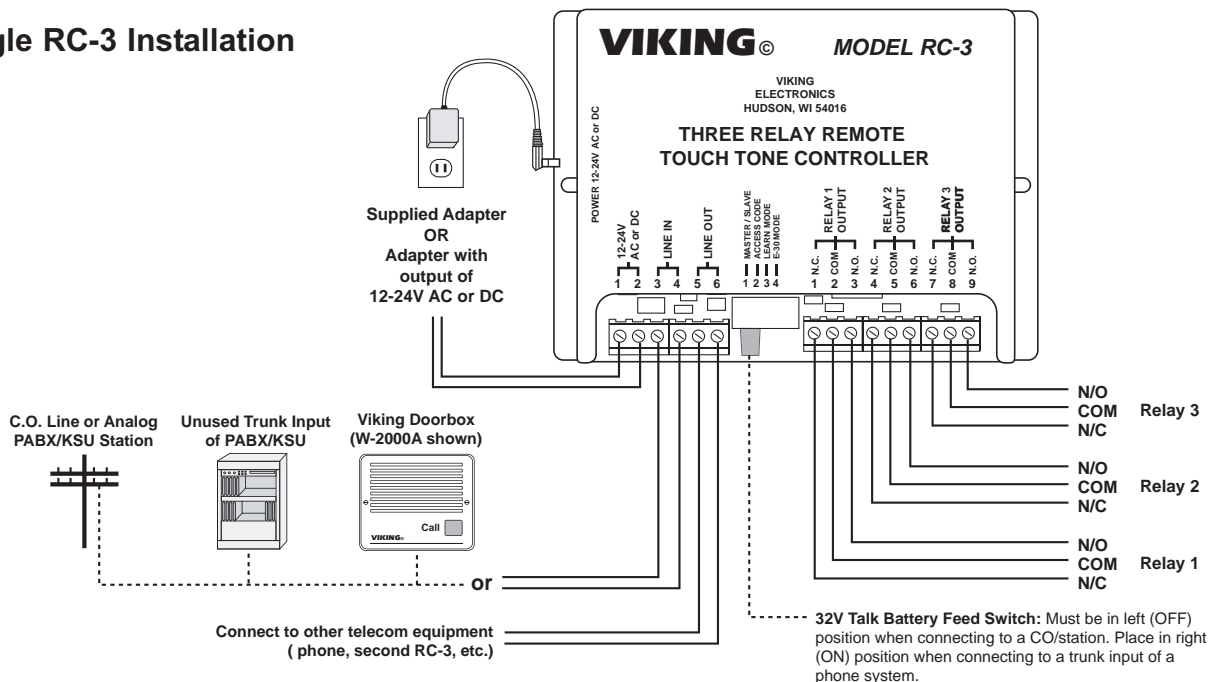

B. Expanding To Control From 4 to 9 Relays

Two or three RC-3's can be daisy chained to the same line to control 1 to 9 relays. One "master" RC-3 can power up to two "slave" RC-3's by daisy chaining power from the power terminals (marked "12-24"). Dipswitch 1 should be turned OFF in each slave unit. This disables the slaves' ring detection and also reduces the total REN loading on the line.

Notes: 1. Each unit must be programmed separately before being connected to the same line (see **Programming**), and all units must be programmed with the same access code.

2. Battery feed switches on both slave units must be in the OFF position for Ring Trip applications. The battery feed switch of slave RC-3 #1 should be set to ON in Trunk applications with only two RC-3's total and OFF with three RC-3's. The battery feed switch of slave RC-3 #2 should be set to ON in Trunk applications.

3. The master battery feed switch should always be set to OFF.

4. When the "relay bank number" is programmed in any RC-3, the timing for "timed activation" of each relay is set back to 5 seconds.

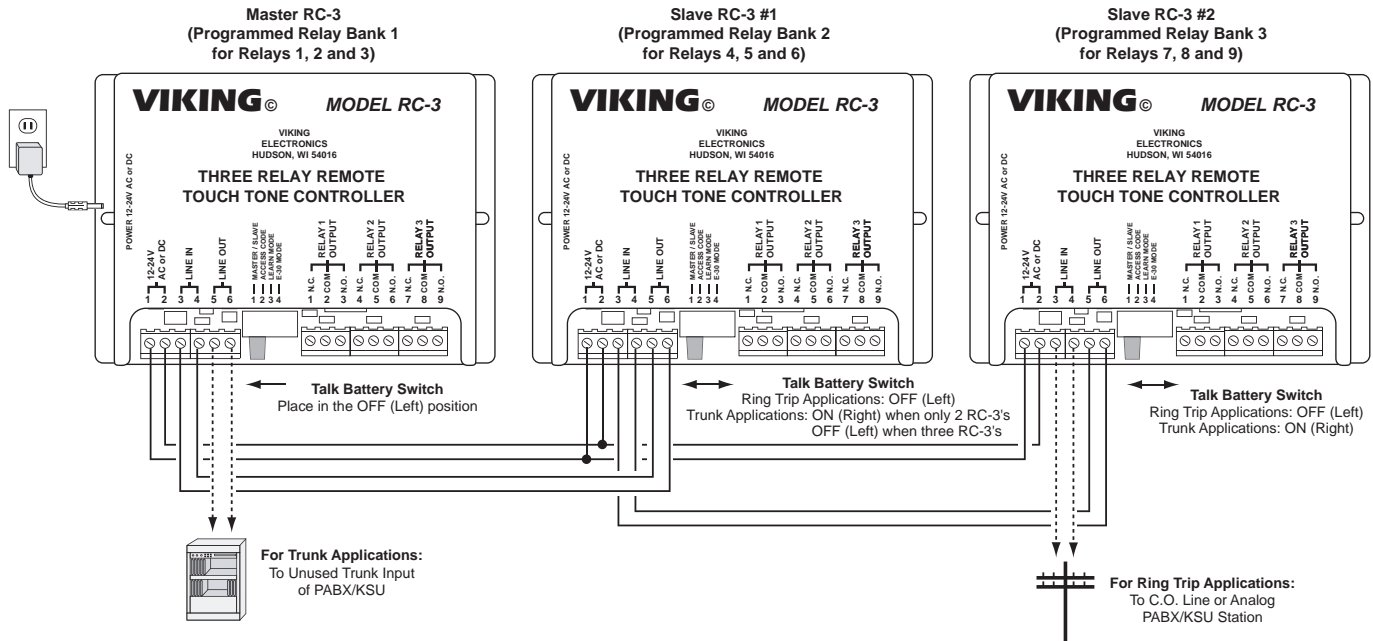

RC-3 Operation Commands

A. Default Relay Commands

The RC-3 is factory programmed with default relay commands that are two digits in length. The first digit is the relay (1-9) to control and the second digit determines if the relay is activated, deactivated or interrogated. To use the default commands, enter the relay number (1-3 for a single unit or 1-9 for multiple units) then enter one of the following digits:

Description	Digit
Activate relay (latch)	1
Deactivate relay (unlatch)	0
Timed activation (factory set to 5 seconds)	2
Interrogate relay status (one beep = deactivated, two beeps = activated)	3

B. Custom Relay Commands

The RC-3 can be programmed to respond to custom relay commands. See **Programming** for a description of how to program custom commands. Note that the commands can consist of any touch tones in the standard 12-tone matrix, that the commands may be one, two or three digits long, but that they must all be the same number of digits. To use custom relay commands, access the RC-3 and enter the relay command as programmed.

Notes: 1. If the number of digits in relay commands is changed in programming, all relay commands and global commands are disabled so they can be reprogrammed with the correct number of digits.

2. The touch tones "*" and "#" can be used in your custom commands but if "*" is the first (or only) digit of a command AND access code is disabled (dip 2 OFF), it will no longer be possible to access programming by dialing "*" + the security code. The only way to enter programming in this case is to either set dip switch 2 ON to enable the access code or turn dip switch 3 ON to enable the learn mode (see **Programming** section A).

3. When custom relay commands have been programmed and a user in the Relay Control State or Unsecure State dials a custom relay command, the RC-3 searches for a match to a programmed relay command starting at memory location "#10". If the digits dialed do not match the command programmed in memory location "#10", the RC-3 checks memory location "#11" and continues searching from the lowest to the highest memory location ("#42"). Once it does find a match to a relay command, it reacts to the first match found and does not search any further. If the same custom relay command is programmed into multiple memory locations, only the command programmed in the lowest memory location will work properly in operation.

C. Default Slave Commands

As shown in **Installation** section **B**, multiple **RC-3** units can be stacked to control up to 9 relays in larger applications. The master unit is assigned relay numbers 1-3, while the first slave has 4-6, and the second slave has 7-9. Default relay commands for the slave units then have a first digit of 4-6 or 7-9, and a second digit the same as the master unit (see section **A** above).

Note: The procedure for programming slave **RC-3**s is described in **Installation** section **B** and **Programming** section **D. Quick Programming Features**. When the relay bank number is set in programming to 2 or 3 (which sets the unit up to act as a slave), the default relay commands are automatically reprogrammed, so that the first digit of the commands are 4-6 or 7-9 instead of 1-3. Also, the timed activation of all relays is set back to 5 seconds following any relay bank number programming. For these reasons, it is important that the relay bank number be set first, before any other slave programming.

D. Custom Slave Commands

Slave **RC-3**s can be programmed with custom relay commands as well. The same limitations and requirements apply as with the custom relay commands.

E. Default Global Commands

To force the **RC-3** to hang up 01

To start a timed activation for all relays 02

F. Custom Global Commands

As with the **RC-3** relay commands, custom global commands may be programmed as well. The same limitations and requirements apply as with the custom relay commands.

Programming

A. DIP Switch Programming

DIP Switch	Position	Description
1	OFF	Unit configured as a Slave
1	ON*	Unit configured as a Master
2	OFF	Access Code disabled
2	ON*	Access Code enabled
3	OFF*	Learn Mode disabled
3	ON	Learn Mode enabled
4	OFF*	** E-30 Mode disabled
4	ON	** E-30 Mode enabled

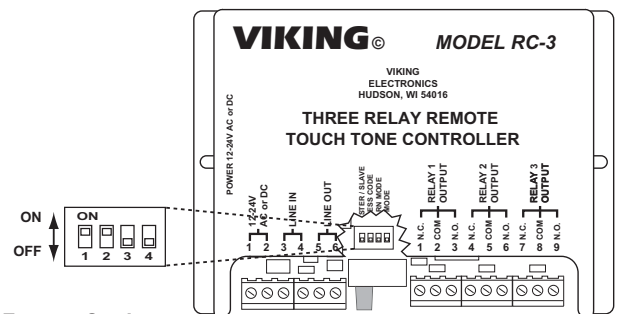

* Factory Settings

** **Note:** When the **RC-3** is switched into or out of the E-30 Mode, the timing for the "timed activation" of each relay is set back to 5 seconds. See **Operation**, section **E**.

B. Entering the Programming Mode

Notes: 1. The touch tones "*" and "#" can be used in your custom commands but if "*" is the first (or only) digit of a command AND access code is disabled (dip 2 off), it will no longer be possible to access programming by dialing "*" plus the security code. The only way to enter programming in this case is to either turn on dip switch 2 to enable access code or turn on dip switch 3 to enable the learn mode (see **Programming** section **A. DIP Switch Programming**).

2. If the E-30 Mode has been enabled (dip switch 4 on), "#" plus the security code is used to enter the programming mode, rather than "*" plus security code.

3. Programming can only be accessed in the Series, Trunk or Ring Trip Connections. There is no way to access the program mode in Parallel Connection.

1. To Locally Program the RC-3 (without connecting the unit to a telco line)

Step 1.	Connect a touch tone phone to the OUT terminals.
Step 2.	Place the TALK BATTERY switch in the ON position.
Step 3.	Come off hook.
Step 4.	Enter * and the security code (factory set to 845464).
Step 5.	Two beeps should be heard. You are now in the programming mode.

- OR -

Step 1.	Connect a touch tone phone to the OUT terminals.
Step 2.	Place the TALK BATTERY switch in the ON position.
Step 3.	Turn dip switch 3 (Learn Mode) ON .
Step 4.	Come off hook.
Step 5.	Two beeps indicate that you are in programming.
Step 6.	Be sure to return dip switch 3 to the OFF position when finished.

Note: To leave programming, hang up. The 20 second Programming Timer is not running while locally programming.

2. To Remotely Program the RC-3

Step 1.	Place the TALK BATTERY switch in the OFF position.
Step 2.	Connect the IN screw terminals to a CO line or analog PABX/KSU extension.
Step 3.	Call into the unit.
Step 4.	When the unit answers, one or two beeps should be heard.
Step 5.	Enter * plus the security code (factory set to 845464).
Step 6.	Two beeps indicate that you are in programming.

- OR -

Step 1.	Place the TALK BATTERY switch in the OFF position.
Step 2.	Connect the IN screw terminals to a CO line or analog PABX/KSU extension.
Step 3.	Turn DIP switch 3 (Learn Mode) ON.
Step 4.	Call into the unit.
Step 5.	The unit answers after one ring and two beeps indicate that you are in programming.
Step 6.	Be sure to return dip switch 3 to the OFF position when finished.

Note: To leave programming, enter **##7** for immediate **RC-3** hang up or just hang up the remote phone and the **RC-3** will hang up 20 seconds later.

C. Programming Acknowledgment Beeps

The **RC-3** acknowledges each correct programming entry with two beeps, and indicates incorrect entries by giving three beeps.

Note: During remote programming, a 20-second timer is running in the background. The timer is reloaded whenever a touch tone is entered, so it is possible to stay in programming as long as at least one touch tone is entered every 20 seconds. If no touch tones are entered for 20 seconds, the programming timer expires, the **RC-3** gives three beeps and hangs up.

D. Quick Programming Features

Acknowledgement Tones	Enter Digits
Enable acknowledgement tones (factory setting)	*1
Disable acknowledgement tones	*2

Programming Relay Commands and Relay Timing	Enter Digits	-then-	Memory Location
Latch Relay 1 OFF	1-3 digits	+	#10
Latch Relay 1 ON	1-3 digits	+	#11
Relay 1 timed closure	1-3 digits	+	#12
Interrogate Relay 1	1-3 digits	+	#13
Relay 1 timed relay activation (HHMMSS), 18 hour maximum (000000 or blank is disabled, factory set to 5 seconds)	6 digits	+	#14
Latch Relay 2 OFF	1-3 digits	+	#20
Latch Relay 2 ON	1-3 digits	+	#21
Relay 2 timed closure	1-3 digits	+	#22
Interrogate Relay 2	1-3 digits	+	#23
Relay 2 timed relay activation (HHMMSS), 18 hour maximum (000000 or blank is disabled, factory set to 5 seconds)	6 digits	+	#24
Latch Relay 3 OFF	1-3 digits	+	#30
Latch Relay 3 ON	1-3 digits	+	#31
Relay 3 timed closure	1-3 digits	+	#32
Interrogate Relay 3	1-3 digits	+	#33
Relay 3 timed relay activation (HHMMSS), 18 hour maximum (000000 or blank is disabled, factory set to 5 seconds)	6 digits	+	#34
To enter * as part of a command	**		
To enter # as part of a command	*#		
Disable any of the above relay commands or timing	#	+	memory location

Programming Unit Operation	Enter Digits	-then-	Memory Location
Hang up (factory set to 01)	1-3 digits	+	#41
Timed activation all programmed relays (factory set to 02)	1-3 digits	+	#42
Security code (factory set to 845464)	6 digits (0-9)	+	#51
Access code (factory set to 123456)	1-6 digits (0-9)	+	#52
Ring delay before answering (1 to 99 rings, 00 = disabled, factory set to 15)	1-2 digits	+	#53
Set relay bank number (when using two or three RC-3's on the same line, factory set to relay bank 1)	1, 2 or 3	+	#54
Access code timeout in seconds (120 secs max, 3 sec min, factory set to 20 secs)	1-3 digits	+	#55
Digits in relay commands (factory set to 2, Caution: This will erase all relay and global commands)	1, 2 or 3	+	#56
To enter * as part of a command	**		
To enter # as part of a command	*#		
Return programming to defaults	###		
Disable any of the above commands	# + memory location		

Note Programming a Slave Unit: If using #54 to set the relay bank number, this must be done before setting the number of digits in relay commands (#56) or programming the individual relay commands. See **RC-3 Operation Commands, C. Default Slave Commands.**

Unit Function	Enter Digits
Hang up in programming	##7

E. Enable / Disable Acknowledgement Tones

With acknowledgement tones enabled (“*1”), the **RC-3** confirms valid relay or global commands with acknowledgement beeps. Two beeps are provided when the relay is currently activated and a single beep is provided when the relay is currently deactivated.

These acknowledgement tones can be disabled in programming using the “*2” programming command. This will only disable acknowledgement tones following relay activation commands, relay interrogation commands or the timed activation of all relays global command. All other operational beeps are still provided by the **RC-3**. It will still provide one or two beeps when it answers a call (in Ring Trip Connection), two beeps after a valid Access Code has been dialed (if Access Code is enabled), a single beep when the 3 second Interdigit Timer expires (incorrect length relay command has been dialed), three beeps when the Access Timer has expired (if applicable) and three beeps when the touch tone hang up command has been dialed.

Operation

A. Trunk Connection

In the Trunk Connection, the **RC-3** can be accessed by going off hook on the analog phone or trunk input connected to the OUT terminals of the **RC-3** (see **Installation**, section **A**). If the Access Code is disabled, the user has immediate access and can begin entering Relay Commands. If the Access Code is enabled, the user enters “*” plus the Access Code, hears two acknowledgement beeps, enters the Relay Control State and can start controlling the relays. The Access Timer is not running in the trunk mode. To leave the Relay Control State, just hang up the phone or trunk input.

B. Ring Trip Connection

In the Ring Trip Connection, the **RC-3** can be accessed by calling the CO line or station connected to the IN terminals of the **RC-3** (see **Installation**, section **A**). The **RC-3** answers after its programmed ring delay. If the Access Code is disabled, the unit gives two acknowledgment beeps to indicate that it is ready to receive Relay Commands. If the Access Code is enabled, the **RC-3** gives a single beep as a prompt to enter the Access Code. The user enters “*” plus the Access Code, hears two beeps, enters the Relay Control State and can start controlling the relays. The Access Timer is running in the background and will pull the **RC-3** out of the Relay Control State, provide three beeps and hang up if the timer expires. To reenter the Relay Control State it is necessary to call the unit again and reenter the Access Code. To leave the Relay Control State, either hang up, allowing the Access Timer to expire, or enter the hang up command. The default value for this command is “01”, but this can be programmed to any 1 – 3 digit number (see **Programming**).

C. Parallel Connection

While the **RC-3** is designed to be used in either the Trunk or Ring Trip Connection as described above, it may also be used in the Parallel Connection. This is done by connecting the IN terminals of the **RC-3** in parallel with a CO line, station or other analog phones. Be sure to leave the **RC-3**'s talk battery switch turned OFF if talk battery is being supplied by another source. If the Access Code is disabled, the **RC-3** continuously monitors touch tones and acts on any match to a relay command it detects, even if they are preceded by or followed by other touch tones. If the Access Code is enabled, a user that enters “*” plus the Access Code will hear two beeps, enters the Relay Control State and can start controlling the relays. The Access Timer is running in the background and will pull the **RC-3** out of the Relay Control State and provide three beeps if the timer expires. To reenter the Relay Control State it is necessary to dial “*” and reenter the Access Code. It should be noted that the Parallel Connection is not suited for applications that require more than a very minimal level of security. The program mode of the **RC-3** can not be accessed in the Parallel Connection.

D. Series Connection

In the Series Connection, a CO line or analog PABX/KSU station is connected to the IN terminals and a Viking entry phone or any other standard analog phone is connected to the OUT terminals of the **RC-3**. The **RC-3** can be accessed any time the entry phone is using the CO line or PABX station. If the Access Code is disabled, the user has immediate access and can begin entering Relay Commands. If the Access Code is enabled, the user enters “*” plus the Access Code, hears two acknowledgement beeps, enters the Relay Control State and can start controlling the relays. The Access Timer is not running in the Series Connection. The **RC-3** leaves the Relay Control State when the phone or entry phone hangs up.

E. E-30 Mode

1. Setting up the E-30 Mode

To program the **RC-3** to operate in the **E-30** mode, just flip DIP switch 4 to the ON position. The **RC-3** automatically programs the **E-30** relay/global commands, sets all three timed relay closures to five seconds, and sets the access code to *. The E-30 Mode was designed to make the **RC-3** and **E-30** handsfree speakerphones fully compatible with one another when used on the same CO line or PABX/KSU station. This mode forces **RC-3** commands to fixed values that will not interfere with **E-30** operation. The programming mode of either the **RC-3** or the **E-30** can be accessed remotely and **RC-3** relays can be controlled during outgoing or incoming calls. Any programmed custom relay commands have no affect in the **E-30** mode. The **E-30** mode is compatible with expanding to two or three **RC-3**'s on the line. Relay bank number programming still applies for the second and third **RC-3** to change their relay codes. Since this mode of operation uses "*" for relay control, "#" plus the valid security code must be used to access the programming mode. The **E-30** mode relay commands are two digits in length and are very similar to the default relay commands. The first digit is the relay (1 to 9) to control and the second digit determines if the relay is activated, deactivated or interrogated. To use the **E-30** relay commands, enter the relay number (1-3 for a single unit or 1-9 for multiple units) then enter one of the following digits:

Description	Digit
Activate relay (latch)	9
Deactivate relay (unlatch)	*
Timed activation (factory set to 5 seconds)	2
Interrogate relay status (one beep = deactivated, two beeps = activated)	3

The **E-30** mode global commands are set as follows:

Description	Digits
To force the RC-3 to hang up	*1
To start timed activation for all relays	*2

Note 1: The relay numbers change from 1-3 to 4-6 when programmed to relay bank number 2 (2#54). The relay numbers change to 7-9 when programmed for relay bank 3 (3#54).

Note 2: The Access Code can be disabled in the E-30 mode but this is not recommended when the **E-30**'s are programmed to dial phone numbers or extension numbers.

Note 3: The **RC-3** will not provide any error beeps when "#" is dialed or when "#" plus six digits are dialed that do not match the security code.

Note 4: The **E-30** can not be programmed to dial a "*" touch tone as part of a phone number (for example, programming the E-30 to dial "*67" before the rest of the number to block caller ID data). The "*" from the **E-30** will set the **RC-3** to the Relay Control State.

Note 5: Programming a pause as part of a phone number in the **E-30** will set the **RC-3** to the Relay Control State, since a pause in the **E-30** is programmed with "*7". If pauses are needed in the E-30 dial string, remove power to all **RC-3**'s that are on the line while programming the **E-30**'s, then reconnect power to the **RC-3**'s when finished programming.

Note 6: In the E-30 Mode, if you access the program mode of the **RC-3** and attempt to program custom relay commands, custom global commands or the access code, the **RC-3** will provide three error beeps. Custom commands can not be programmed in the E-30 mode.

Note 7: When the **RC-3** is switched into or out of the E-30 mode, the timing for "timed activation" of each relay is set back to five seconds. This can be changed to any value up to 18 hours.

2. Operation in the E-30 Mode (Access Codes Enabled - Dipswitch 2 ON)

Outgoing Calls: When the button is pushed on an **E-30**, the **E-30** starts dialing its programmed phone numbers. When the call is answered, the user enters a "*", they hear two beeps and can start controlling the relays. The Access Timer is not running in the E-30 Mode if the CO line or PABX/KSU station is connected to the IN terminals and the **E-30**'s are connected to the OUT terminals of the **RC-3**. If the **RC-3** is wired in parallel to the CO line or PABX/KSU station (nothing connected to the OUT terminals of the **RC-3**), the Access Timer will be running and will pull the **RC-3** out of the Relay Control State and provide three beeps if the timer expires (to reenter the Relay Control State it is necessary to dial "*" again).

Inbound Calls: Call the CO line or PABX/KSU station connected to the **RC-3** and **E-30**'s and wait for an **E-30** or the **RC-3** to answer the call. You can then enter the "*", will hear two beeps and can start controlling the relays. Whether the Access Timer is running or not running depends on how the **RC-3** is connected, as described above in "Outgoing Calls".

F. Notes for All Modes of Operation

1. If the timed activation of a relay is disabled by programming "000000" (or blank) as the time value, the **RC-3** will provide three error beeps when a user in the Relay Control State or Unsecure State attempts to dial the timed activation command for that relay.
2. When custom relay commands have been programmed and a user in the Relay Control State or Unsecure State dials a custom relay command, the **RC-3** searches for a match to a programmed relay command starting at memory location "#10". If the digits dialed do not match the command programmed in memory location "#10", the **RC-3** checks memory location "#11" and continues searching from the lowest to the highest memory location ("#42"). Once it does find a match to a relay command, it reacts to the first match found and does not search any further. If the same custom relay command is programmed into multiple memory locations, only the command programmed in the lowest memory location will work properly in operation.

Product Support Line...715.386.8666

Fax Back Line...715.386.4345

Due to the dynamic nature of the product design, the information contained in this document is subject to change without notice. Viking Electronics, and its affiliates and/or subsidiaries assume no responsibility for errors and omissions contained in this information. Revisions of this document or new editions of it may be issued to incorporate such changes.