

Subminiature Automotive Relay SRMA



- High current contact capacity
- Switching capacity up to 20A (at 85°C)
- Improved heat resistance
- Extended operation range
- High resistance to vibration and shock
- Two types of contact material



Options and ordering codes

SRMA	-	1C		T	-	S		L	-	24VDC
		Coil Voltage								
Contact form		1A								
SPNO		1C								
SPCO										
		RoHS Compliant								
Contact material		T		S	Sealing					
AgSnO ₂		N		F	Sealed					
AgNi					Flux Tight					

Contact Data

Contact arrangement	1A, 1C
Voltage drop (initial) ¹⁾	Typ.: 100mV (at 10A) Max.: 250mV (at 10A)
Max. carrying current (NO contact)	35A/10min. 25A/1h ²⁾
Max. switching current	NO/NC: 25/20A (at 16VDC)
Max. switching voltage	60VDC
Max. switching Power	210W
Contact rating	Resistive: 15A 14VDC Motor locked: 20A 14VDC Motor free: Break: 4A 14VDC Shock: 20A 14VDC
Min. contact load	1A 6VDC
Mechanical life	1x10 ⁷ OPS
Electrical life	2x10 ⁵ OPS

¹⁾ Equivalent to the max.initial contact resistance is 100MΩ (1A 6VDC)
²⁾ 25°C, measured when coil is energized with 100% nominal voltage

Coil Data

at 20°C

Nominal Voltage VDC	Pick-Up Voltage VDC		Drop Out Voltage VDC 20°C	Coil resistance Ω	Power Consumption W
	20°C	85°C			
6	3.6	4.5	0.5	60	0.6
9	5.4	6.8	0.7	135	0.6
10	6.3	7.9	0.8	180	0.6
12	7.3	9.0	1.0	240	0.6
18	10.8	13.5	1.5	540	0.6
24	14.4	18.0	2.2	960	0.6

Characteristics

Initial Insulation Resistance	100MΩ @ 500VDC	
Dielectric Strength	Between coil & contact	500VAC, 1min.
	Between open contacts	500VAC, 1min.
Operate time (at nomi. Volt)	Max. 10ms	
Release time (at nomi. Volt)	Max. 5ms	
Temperature rise (at nomi. Volt)	Max. 60°C	
Shock resistance	Functional	100m/s ²
	Destructive	1000m/s ²
Vibration resistance	DA:1.5mm, 10 to 55Hz	
Humidity	98% +40°C	
Ambient temperature	-40°C to +85°C	
Storage temperature	-40°C to +155°C	
Termination	PCB	
Unit Weight	6g	
Construction	Sealed IP67 & Flux proof	

Subminiature Automotive Relay SRMA



Outline dimensions (mm)

Wiring diagram and PC Board layout

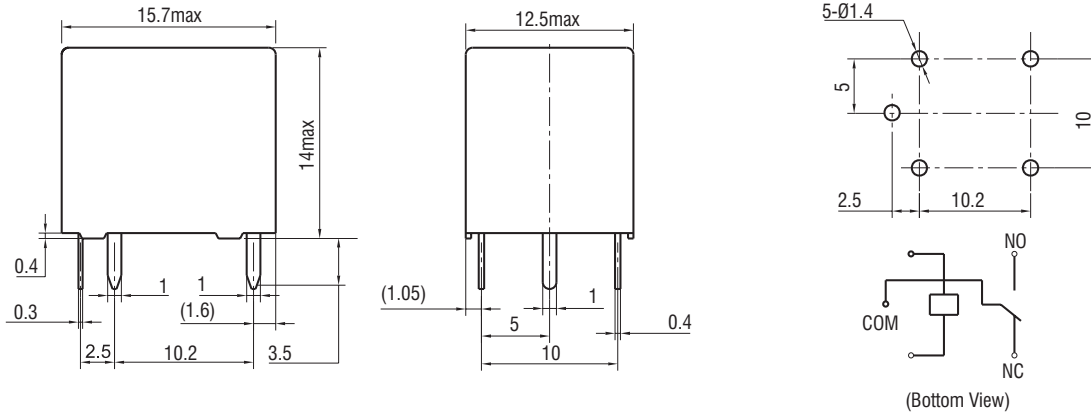

Characteristic Curve

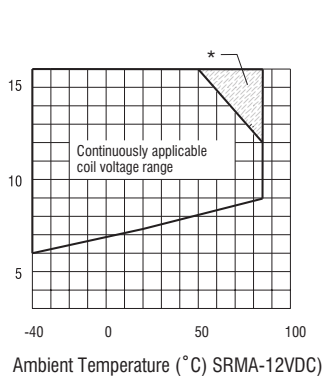
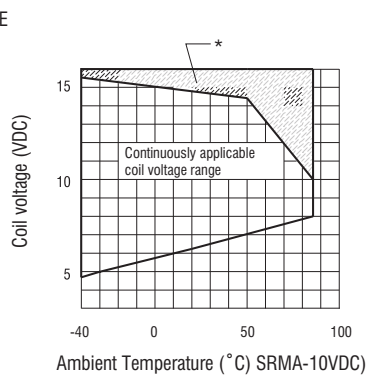
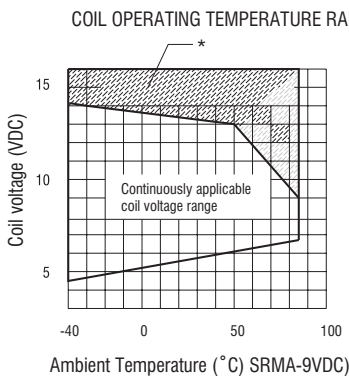
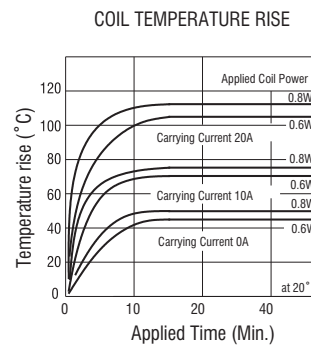
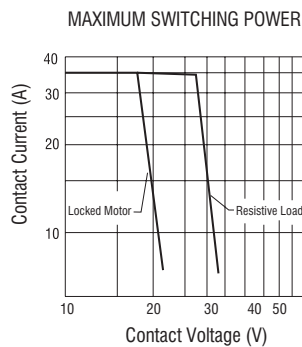
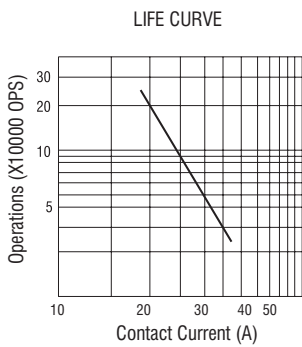

* Intermittent coil operation is required in this region at 20A or more carrying current

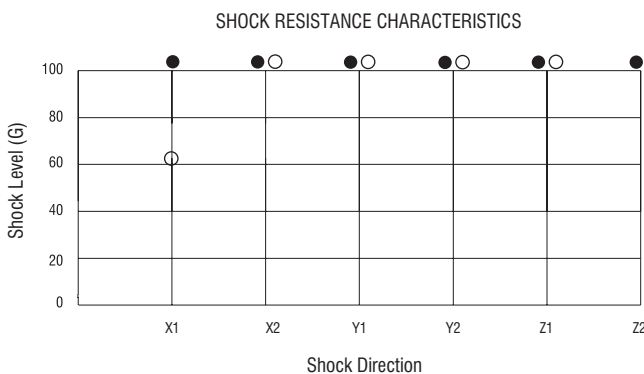

Shock application time: 11ms
Test Material: Coil Energised & De-Energised
Shock Direction: See diagram
Detection Levels: 100 us

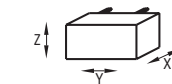

○: NC Contact
●: NO Contact

VIBRATION RESISTANCE CHARACTERISTICS

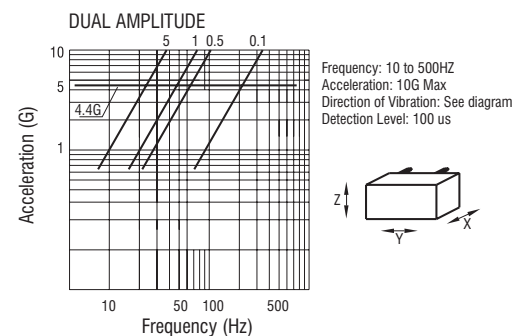

Frequency: 10 to 500Hz
Acceleration: 10G Max
Direction of Vibration: See diagram
Detection Level: 100 us

