

Subminiature High Power Relay SRC



- 12A switching capabilities
- SPNO configuration
- Subminiature, standard PCB layout
- Sealed Construction
- UL Approved



Options and ordering codes

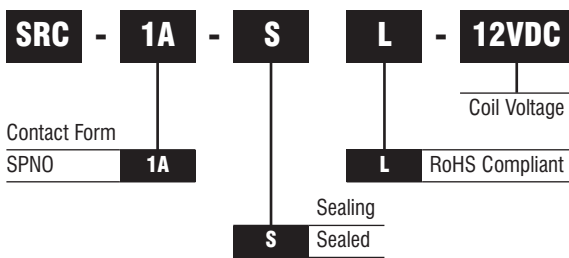

Contact Data

Contact Arrangement	1A
Initial Contact Resistance Max.	100mΩ (at 1A 24VDC)
Contact Material	AgSnO ₂
Contact Rating (Res. Load)	10A 277VAC/30VDC 12A 125VAC
Max. switching voltage	277VAC
Max. switching current	12A
Max. switching power	2770VAC/300W
Mechanical life	1x10 ⁷ ops
Electrical life	1x10 ⁵ ops

Characteristics

Initial Insulation Resistance	1000MΩ @ 500VDC	
Dielectric Strength	Between coil & contact	2500VAC 1min.
	Between open contacts	1000VAC 1min.
Operate time (at nomi. Volt)	Max. 8ms	
Release time (at nomi. Volt)	Max. 5ms	
Shock resistance	Functional	100m/s ²
	Destructive	1000m/s ²
Vibration resistance	1.5mm, 10 to 55Hz	
Humidity	35% to 95%	
Ambient temperature	-40°C to 85°C	
Termination	PCB	
Unit Weight	Approx. 6g	
Construction	Sealed IP67	

Coil

Coil power	0.45W
------------	-------

Coil Data

Nominal Voltage VDC	Pick-up Voltage VDC	Drop-out Voltage VDC	Max. allowable Voltage (at 20°C)	Coil Resistance Ω
3	2.25	0.15	3.90	20±10%
5	3.75	0.25	6.50	55±10%
6	4.50	0.30	7.80	80±10%
9	6.75	0.45	11.7	180±10%
12	9.00	0.60	15.6	320±10%
18	13.5	0.90	23.4	720±10%
24	18.0	1.20	31.2	1280±10%

Safety Approval Ratings

UL	12A 125VAC
	10A 277VAC
	13.5A 125VAC
	10A 30VDC
	TV-5
	1/4HP 125/250VAC

Subminiature High Power Relay SRC



Outline dimensions (mm)

Wiring diagram and PC Board layout

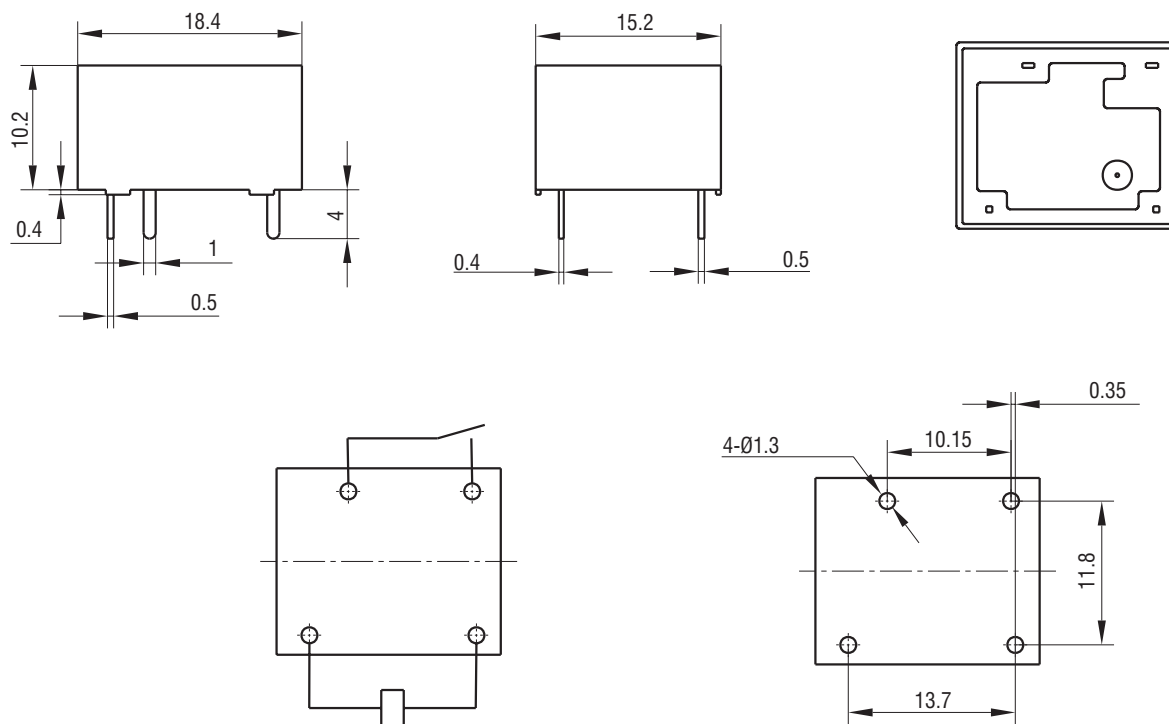

Characteristic Curve

