

REVISIONS			
REV	ECN, ERN NO.	DATE	APPRD.
A	PRODUCT DRAWING (EAR 13448)	JAN15/09	L.C.

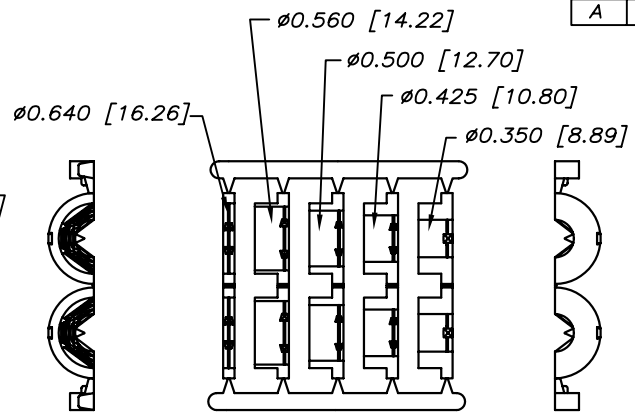

JACKET INSERT TREE

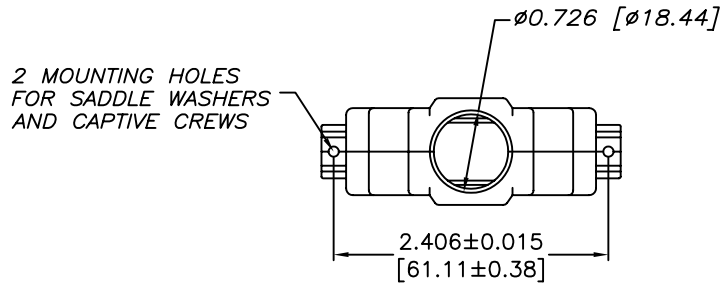
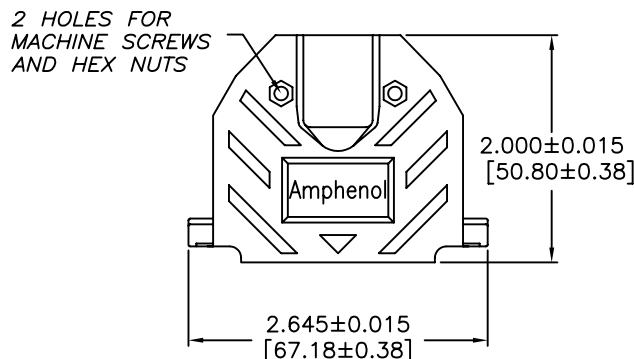
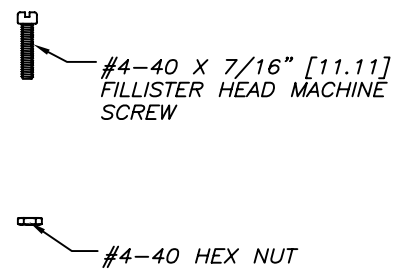

CONNECTOR BACKSHELL

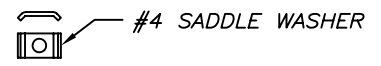
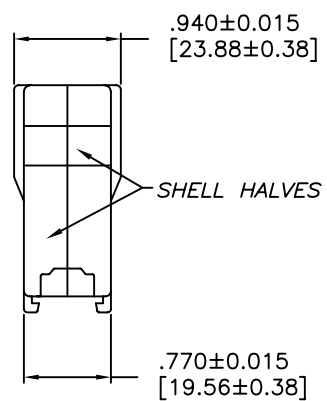

NOTES:

- 1) EACH BACKSHELL KIT CONTAINS 2 SHELL HALVES, 1 JACKET INSERT TREE AND 2 OF EACH HARDWARE ITEM SHOWN.
- 2) BACKSHELL IS SUITABLE FOR SUBMINIATURE D CONNECTOR, D SIZE SHELL (50 POSITION STANDARD CONTACTS OR 78 POSITION HIGH DENSITY CONTACTS).
- 3) JACKET INSERTS ARE DESIGNED FOR A CABLE DIAMETER RANGE OF .350 [8.89] TO .640 [16.26]. REMOVE THE SUITABLE INSERT FROM THE TREE AND INSTALL IT INTO THE CABLE CLAMP PORTION OF THE BACKSHELL.
- 4) MATERIALS - ALL MATERIALS ARE RoHS COMPLIANT
 SHELL - THERMOPLASTIC, UL FLAMMABILITY RATING UL94V-0, TOLERANCE: ± 0.015 [0.381]
 INSERT TREE - POLYPROPYLENE HOMOPOLYMER, TOLERANCE: ± 0.010 [0.254]
 HARDWARE - STEEL, ZINC PLATED, TRIVALENT CHROMATE FINISH



THIS DOCUMENT CONTAINS PROPRIETARY INFORMATION AND SUCH INFORMATION MAY NOT BE DISCLOSED TO OTHERS FOR ANY PURPOSE OR USED FOR MANUFACTURING PURPOSES WITHOUT WRITTEN PERMISSION FROM AMPHENOL CANADA CORP.

DRAWN DAVIE.W	DATE JAN14/09	Amphenol Canada Corp.	
DESIGNED			
CHECKED L. CHAN	DATE JAN15/09	17E SERIES D-SUB CONNECTOR BACKSHELL, D SIZE SHELL (50 STD OR 78 HD CONTACTS) 2 PIECE, PLASTIC, STRAIGHT EXIT #4-40 THREAD, RoHS COMPLIANT	
I. E. APPRD.			
Q. A. APPRD.			
DWG. APPRD.			
ENG. REL. NO. EAR 13448	DWG C	DRAWING NO. P-17E-1728-1	REV. A
REF.	DIMENSIONS ARE IN INCHES [mm]	CODE ID. NO. 03554	SCALE 1/1
		WT. -----	SURF. -----
		SHEET 1 OF 1	