

REVISIONS			
REV	ECN, ERN NO.	DATE	APPRD.
A	PRODUCT DRAWING (EAR 12956)	OCT03/06	K.L.

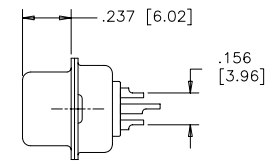
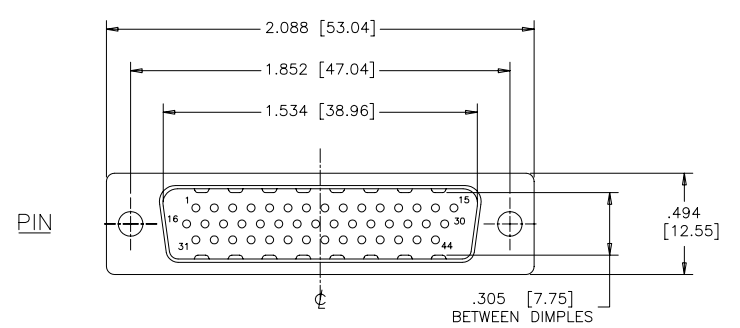

ORDERING CODE:

PART NUMBER: 1 7 E H D - 0 4 4 P A M - 1 0 0

SERIES _____

NUMBER OF CONTACTS
044

STYLE
P=PIN
S=SOCKET

TERMINATION-MOUNTING OPTIONS
 000= SOLDER CUP, .120 [3.05] DIA. THROUGH HOLE
 100= SOLDER CUP, #4-40 UNC THREADED HOLES
 200= SOLDER CUP, #4-40 UNC HEX JACK SOCKETS INSTALLED

CONTACT PLATING OPTIONS FOR ENGAGEMENT AREA
 AA= 3μ" [0.08 MICRONS] GOLD FLASH
 CH= 15μ" [0.38 MICRONS] GOLD
 AM= 30μ" [0.76 MICRONS] GOLD

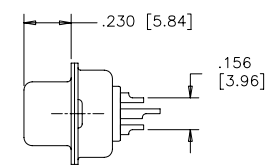
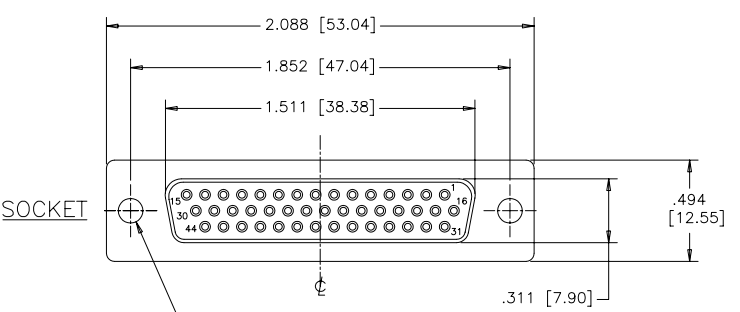

SPECIFICATIONS:

MATERIALS: ALL MATERIALS ARE RoHS COMPLIANT
SHELL: STEEL, TIN PLATED
INSERTS: HIGH TEMPERATURE RESISTANT NYLON, GLASS REINFORCED, UL FLAMMABILITY RATING 94V-0, COLOUR: BLACK
CONTACTS: COPPER ALLOY, GOLD PLATING (SEE ORDERING CODE) OVER 50μ" [1.27 MICRONS] NICKEL ON ENGAGEMENT AREA WITH 100μ" [2.54 MICRONS] MIN. MATTE TIN ON CONTACT TERMINALS.

TERMINATION-MTG OPTION 000
 SOLDER CUP, .120 [3.05] DIA. THROUGH HOLE (2 PLACES)

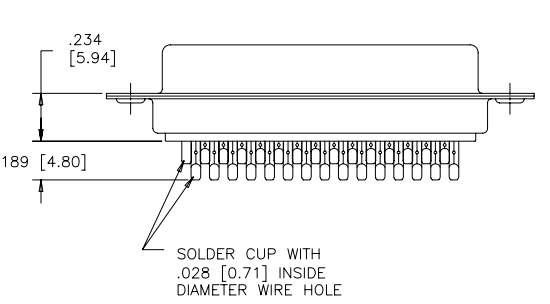

SOLDER CUP WITH .028 [0.71] INSIDE DIAMETER WIRE HOLE

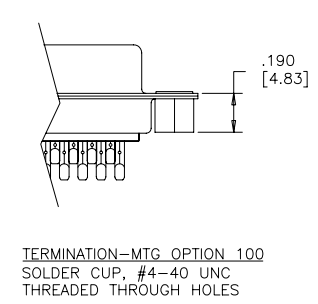

TERMINATION-MTG OPTION 100
 SOLDER CUP, #4-40 UNC THREADED THROUGH HOLES

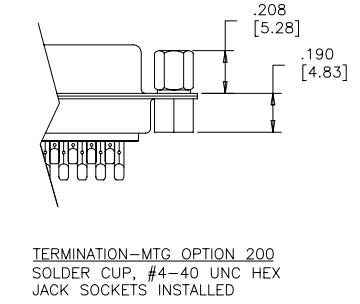

TERMINATION-MTG OPTION 200
 SOLDER CUP, #4-40 UNC HEX JACK SOCKETS INSTALLED

ELECTRICAL DATA:

CURRENT RATING: 3 AMP
CONTACT RESISTANCE: 15 MILLIOHMS MAX.
INSULATION RESISTANCE: 3000 MEGOHMS MIN.
DIELECTRIC WITHSTANDING VOLTAGE: 1000 VAC rms
OPERATING TEMPERATURE: -55°C TO +105°C

THIS DOCUMENT CONTAINS PROPRIETARY INFORMATION AND SUCH INFORMATION MAY NOT BE DISCLOSED TO OTHERS FOR ANY PURPOSE OR USED FOR MANUFACTURING PURPOSES WITHOUT WRITTEN PERMISSION FROM AMPHENOL CANADA CORP.

DRAWN	J.LEE	DATE	OCT03/06
DESIGNED			
CHECKED	K.LAMBIE	DATE	OCT03/06
I. E. APPRD.			
Q. A. APPRD.			
DWG. APPRD.			
ENG. REL. NO.			
REF.	EAR 12956		
DIMENSIONS ARE IN	CODE ID. NO.		
INCHES	03554		

Amphenol Canada Corp.			
TITLE 17EHD SERIES HIGH DENSITY D-SUB CONNECTOR, 44 SIZE, SOLDER CUP, PLATING & MOUNTING OPTIONS, RoHS COMPLIANT			
DWG	DRAWING NO.	REV.	
C	P-17EHD-044XXX-X00	A	
SCALE	2/1	WT.	-----
SURF.	-----	SHEET	1 OF 1