

REVISIONS			
REV	ECN, ERN NO.	DATE	APPRD.
A	PRODUCT DRAWING (EAR 12956)	OCT03/06	K.L.

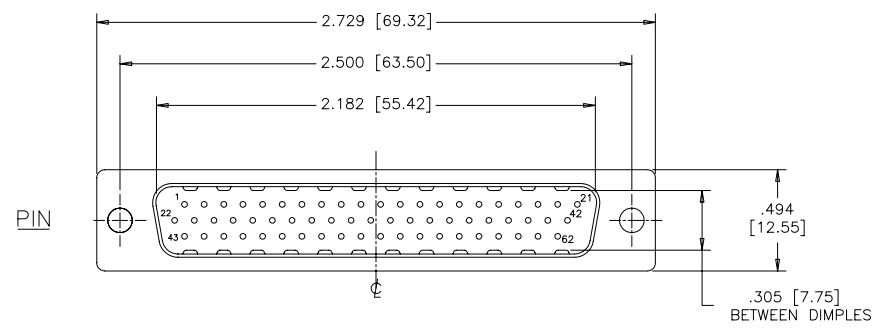

ORDERING CODE:

PART NUMBER: 1 7 E H D - 0 6 2 P A M - 1 0 0

SERIES

NUMBER OF CONTACTS
062

STYLE
P=PIN
S=SOCKET

TERMINATION-MOUNTING OPTIONS
 000= SOLDER CUP, .120 [3.05] DIA. THROUGH HOLE
 100= SOLDER CUP, #4-40 UNC THREADED HOLES
 200= SOLDER CUP, #4-40 UNC HEX JACK SOCKETS INSTALLED

CONTACT PLATING OPTIONS FOR ENGAGEMENT AREA
 AA= 3μ" [0.08 MICRONS] GOLD FLASH
 CH= 15μ" [0.38 MICRONS] GOLD
 AM= 30μ" [0.76 MICRONS] GOLD

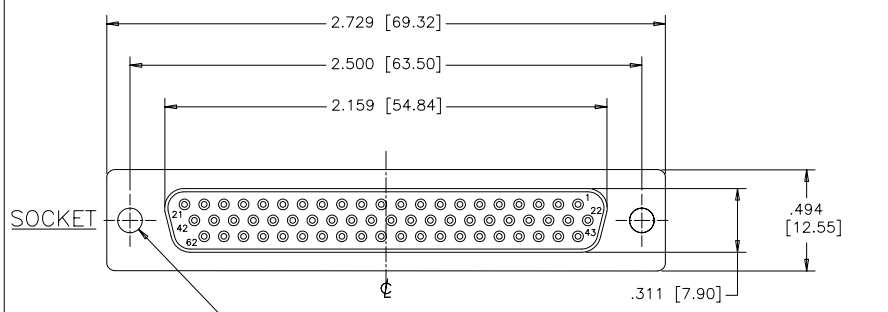

SPECIFICATIONS:

MATERIALS: ALL MATERIALS ARE RoHS COMPLIANT

SHELL: STEEL, TIN PLATED

INSERTS: HIGH TEMPERATURE RESISTANT NYLON, GLASS REINFORCED, UL FLAMMABILITY RATING 94V-0, COLOUR: BLACK

CONTACTS: COPPER ALLOY, GOLD PLATING (SEE ORDERING CODE) OVER 50u" [1.27 MICRONS] NICKEL ON ENGAGEMENT AREA WITH 100u" [2.54 MICRONS] MIN. MATTE TIN ON CONTACT TERMINALS.

TERMINATION-MTG OPTION 000
SOLDER CUP, .120 [3.05] DIA. THROUGH HOLE (2 PLACES)

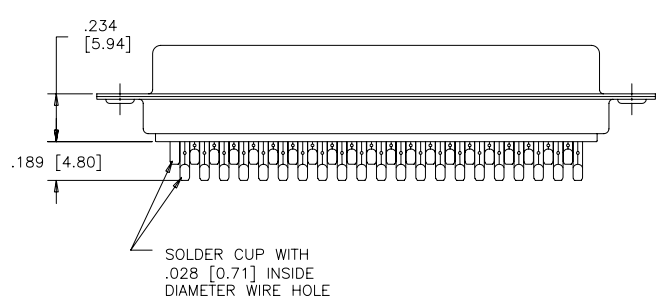

SOLDER CUP WITH .028 [0.71] INSIDE DIAMETER WIRE HOLE

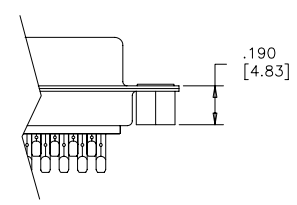

TERMINATION-MTG OPTION 100
SOLDER CUP, #4-40 UNC THREADED THROUGH HOLES

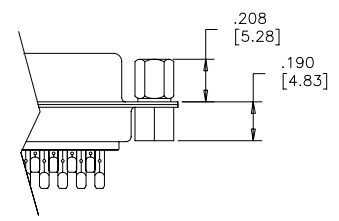

TERMINATION-MTG OPTION 200
SOLDER CUP, #4-40 UNC HEX JACK SOCKETS INSTALLED

ELECTRICAL DATA:

CURRENT RATING: 3 AMP

CONTACT RESISTANCE: 15 MILLIOHMS MAX.

INSULATION RESISTANCE: 3000 MEGOHMS MIN.

DIELECTRIC WITHSTANDING VOLTAGE: 1000 VAC rms

OPERATING TEMPERATURE: -55°C TO +105°C

DRAWN	J.LEE	DATE	OCT03/06
DESIGNED			
CHECKED	K.LAMBIE	DATE	OCT03/06
I. E. APPRD.			
Q. A. APPRD.			
DWG. APPRD.			
ENG. REL. NO.			
REF.	EAR 12956		
DIMENSIONS ARE IN	CODE ID. NO.		
INCHES	03554		

Amphenol Canada Corp.

TITLE 17EHD SERIES HIGH DENSITY D-SUB CONNECTOR, 62 SIZE, SOLDER CUP, PLATING & MOUNTING OPTIONS, RoHS COMPLIANT

DWG	DRAWING NO.	REV.
C	P-17EHD-062XXX-X00	A
DIMENSIONS ARE IN	SCALE	WT.
INCHES	2/1	-----
		SURF. -----
		SHEET 1 OF 1

THIS DOCUMENT CONTAINS PROPRIETARY INFORMATION AND SUCH INFORMATION MAY NOT BE DISCLOSED TO OTHERS FOR ANY PURPOSE OR USED FOR MANUFACTURING PURPOSES WITHOUT WRITTEN PERMISSION FROM AMPHENOL CANADA CORP.