

.318 [8.08] FOOTPRINT
(STANDARD PCB LAYOUT)

REVISIONS			
REV	ECN, ERN NO.	DATE	APPRD.
B	PRODUCT DRAWING (EAR 12937)	APR28/06	K.L.

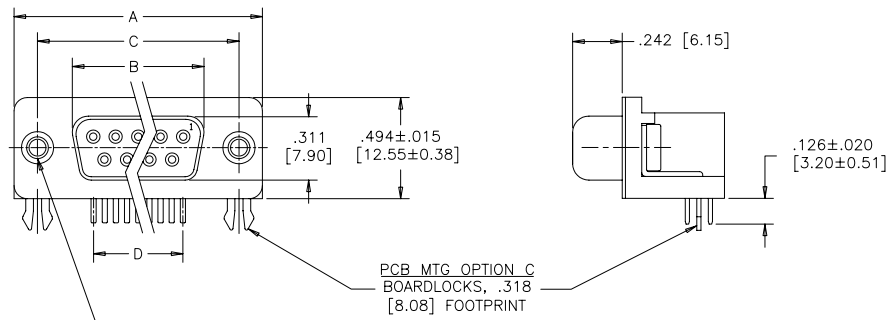

DIMENSIONS

SIZE	A±.015 [0.38]	B±.005 [0.13]	C±.005 [0.13]	D BSC.
009	1.213 [30.81]	.643 [16.33]	.984 [24.99]	.432 [10.97]
015	1.541 [39.14]	.971 [24.66]	1.312 [33.32]	.756 [19.20]
025	2.088 [53.04]	1.511 [38.38]	1.852 [47.04]	1.304 [33.12]
037	2.729 [69.32]	2.159 [54.84]	2.500 [63.50]	1.956 [49.68]

PANEL MTG OPTIONS 0 OR 1
 .120 [3.05] DIA. OR #4-40
 THROUGH HOLES (2 PLACES),
 SEE ORDERING CODE.

PANEL MTG OPTION 2
 #4-40 UNC THREADED HEX
 JACK SOCKET
 (2 INSTALLED)

PCB MTG OPTION A
 ø.120 [3.05] MTG HOLE
 WITH WRAP-AROUND
 GROUND STRAP,
 .318 [8.08] FOOTPRINT

PCB MTG OPTIONS D OR J
 ø.120 [3.05] MTG HOLE OR
 #4-40 THREADED MTG HOLE,
 .318 [8.08] FOOTPRINT

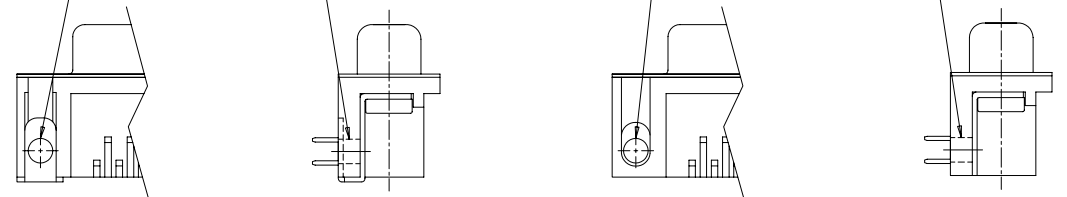
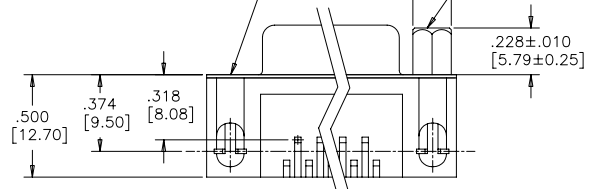

ORDERING CODE:

PART NUMBER: 6 E 1 7 X - X X X S X X - X 2 0 X

SERIES _____

PCB MTG OPTIONS _____

A=ø.120 [3.05] MTG HOLE WITH
 WRAP-AROUND GROUND STRAP,
 .318 [8.08] FOOTPRINT
 C=BOARDLOCK OPTION,
 .318 [8.08] FOOTPRINT
 D=ø.120 [3.05] MTG HOLE,
 .318 [8.08] FOOTPRINT
 J=#4-40 THREADED MTG HOLE,
 .318 [8.08] FOOTPRINT
 U=ø.120 [3.05] MTG HOLE,
 .590 [14.99] FOOTPRINT
 Y=BOARDLOCK OPTION,
 .590 [14.99] FOOTPRINT

NUMBER OF CONTACTS _____

009, 015, 025, 037

STYLE _____

S=SOCKET

PCB LAYOUT CODE
 NO DIGIT=STANDARD
 .374 [9.50] DIM'N FOR .318 [8.08] F/P
 .315 [8.00] DIM'N FOR .590 [14.99] F/P
 E=.646 [16.41] DIM'N FOR .590 [14.99] F/P

SHELL CHARACTERISTICS
 20=TIN PLATED RECEPTACLE SHELL

PANEL MOUNTING OPTIONS
 0=ø.120" [3.05] THROUGH HOLE
 1=#4-40 THREADED HOLE
 2=MOUNTING OPTION 1 WITH #4-40
 UNC HEX JACK SOCKETS INSTALLED

CONTACT PLATING OPTIONS
 BF=ENGAGEMENT AREA 3µ" [0.08 MICRONS] GOLD FLASH
 CF=ENGAGEMENT AREA 15µ" [0.38 MICRONS] GOLD
 AJ=ENGAGEMENT AREA 30µ" [0.76 MICRONS] GOLD

RECOMMENDED P.C.B LAYOUT, STANDARD

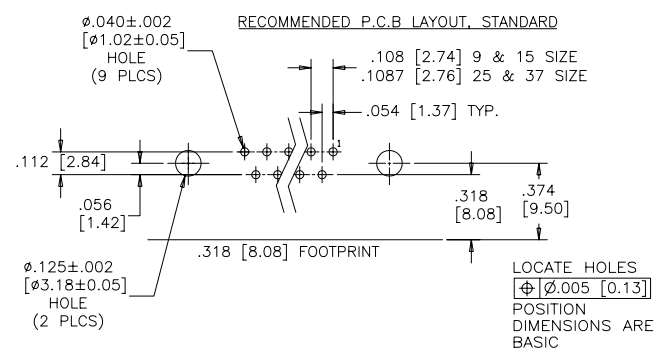

SEE SHEET 2 FOR NOTES & SPECIFICATIONS

DRAWN	A.CHENG	DATE	APR13/06
DESIGNED			
CHECKED	K.LAMBIE	DATE	APR13/06
I. E. APPRD.			
Q. A. APPRD.			
DWG. APPRD.			
ENG. REL. NO.		DWG	DRAWING NO.
REF.	EAR 12937	C	P-6E17X-XXXSXX-X20X
DIMENSIONS ARE IN INCHES		CODE ID. NO.	03554

Amphenol Canada Corp.			
TITLE			
6E17 SERIES D-SUB CONNECTOR, 9 TO 37 SIZE SOCKET, RIGHT ANGLE WITH F/P, MTG AND PLATING OPTIONS, RoHS COMPLIANT			
REV.	B	DWG	DRAWING NO.
		C	P-6E17X-XXXSXX-X20X
SCALE	2/1	WT.	-----
SURF.	-----	SHEET 1 OF 2	

THIS DOCUMENT CONTAINS PROPRIETARY INFORMATION AND SUCH INFORMATION
 MAY NOT BE DISCLOSED TO OTHERS FOR ANY PURPOSE OR USED FOR MANUFACTURING
 PURPOSES WITHOUT WRITTEN PERMISSION FROM AMPHENOL CANADA CORP.

.590 [14.99] FOOTPRINT
(STANDARD PCB LAYOUT)

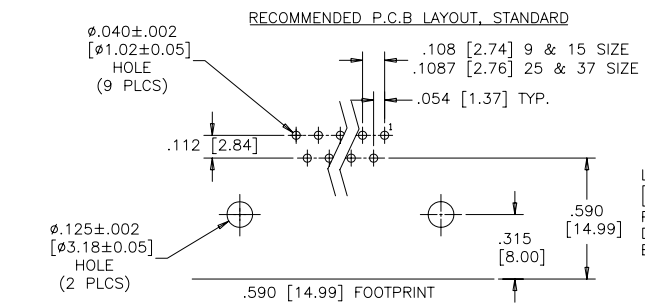
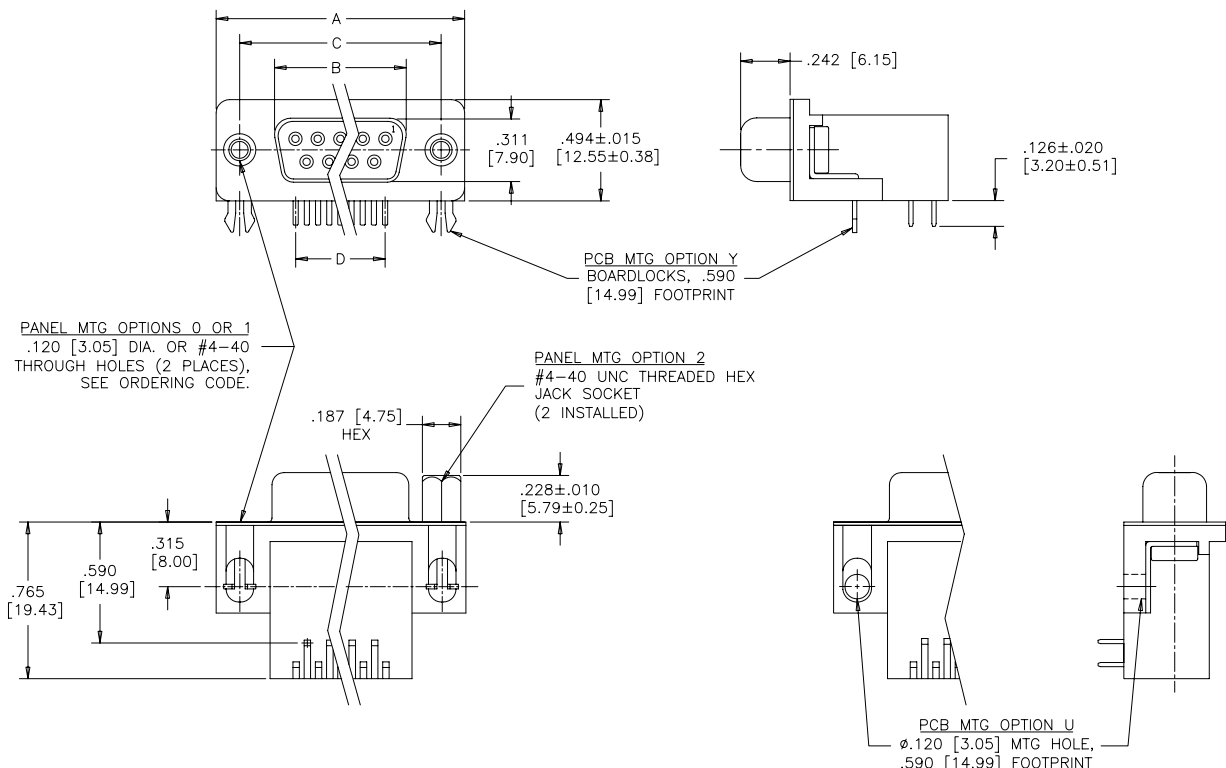

LOCATE HOLES
⊕ Ø.005 [0.13]
POSITION DIMENSIONS ARE BASIC

DIMENSIONS

SIZE	A±.015 [0.38]	B±.005 [0.13]	C±.005 [0.13]	D BSC.
009	1.213 [30.81]	.643 [16.33]	.984 [24.99]	.432 [10.97]
015	1.541 [39.14]	.971 [24.66]	1.312 [33.32]	.756 [19.20]
025	2.088 [53.04]	1.511 [38.38]	1.852 [47.04]	1.304 [33.12]
037	2.729 [69.32]	2.159 [54.84]	2.500 [63.50]	1.956 [49.68]

SPECIFICATIONS:

MATERIALS: ALL MATERIALS ARE RoHS COMPLIANT

SHELL: STEEL, TIN PLATED

INSERTS: HIGH TEMPERATURE RESISTANT NYLON, GLASS REINFORCED, UL FLAMMABILITY RATING 94V-0, COLOUR: BLACK

CONTACTS: COPPER ALLOY, GOLD PLATING (SEE ORDERING CODE) OVER 50u" [1.27 MICRONS] NICKEL ON ENGAGEMENT AREA WITH 100u" [2.54 MICRONS] MIN. MATTE TIN ON CONTACT TERMINALS.

BOARDLOCK: COPPER ALLOY, TIN PLATED

ELECTRICAL DATA:

CURRENT RATING: 5 AMP

CONTACT RESISTANCE: 15 MILLIOHMS MAX.

INSULATION RESISTANCE: 3000 MEGOHMS MIN.

DIELECTRIC WITHSTANDING VOLTAGE: 1000 VAC rms

OPERATING TEMPERATURE: -55°C TO +105°C

.590 [14.99] FOOTPRINT
(PCB LAYOUT CODE E)

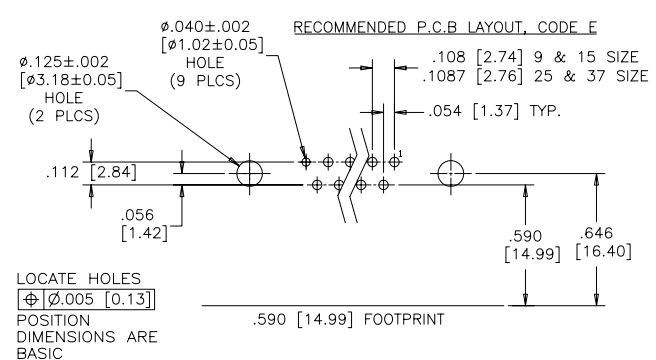
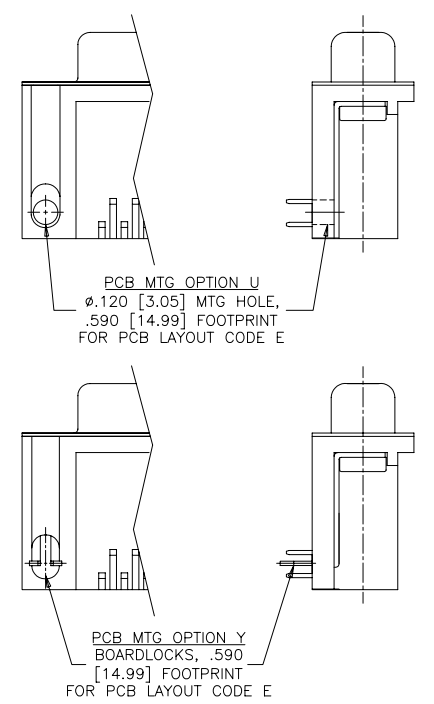

LOCATE HOLES
⊕ Ø.005 [0.13]
POSITION DIMENSIONS ARE BASIC

SEE SHEET 1 FOR ORDERING CODE

Amphenol Canada Corp.

DRAWN	A.CHENG	DATE	APR13/06
DESIGNED			
CHECKED	K.LAMBIE	DATE	APR13/06
I. E. APPRD.			
Q. A. APPRD.			
DWG. APPRD.			
ENG. REL. NO.			
REF.	EAR 12937		
DIMENSIONS ARE IN	INCHES	CODE ID. NO.	03554

6E17 SERIES D-SUB CONNECTOR, 9 TO 37 SIZE SOCKET, RIGHT ANGLE WITH F/P, MTG AND PLATING OPTIONS, RoHS COMPLIANT

DWG	DRAWING NO.	REV.
C	P-6E17X-XXXSXX-X20X	B
SCALE	2/1	WT. -----
SURF.	-----	SHEET 2 OF 2