

REVISIONS			
SYM	ECN, ERN NO.	DATE	APPRD.
P	PRODUCT DWG - EAR 14157	APR25/13	K.L.

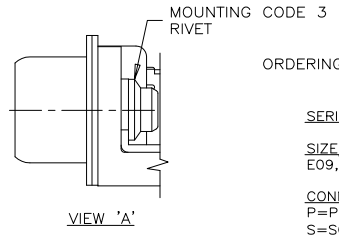
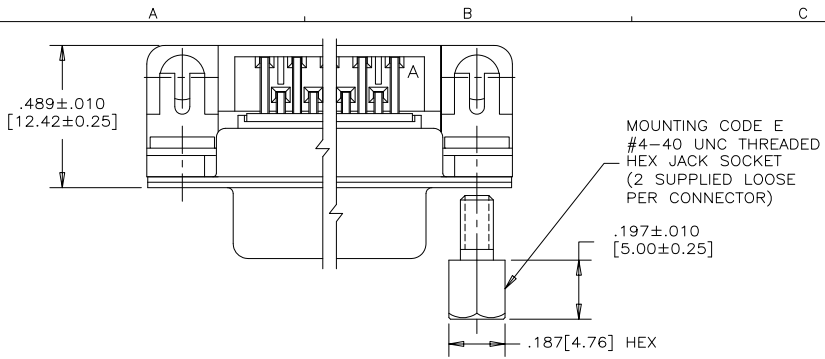

ORDERING CODE: F C C 1 7 - E 0 9 P A - 4 4 0 G

SERIES _____

SIZE/NUMBER OF CONTACTS
E09, A15, B25, OR C37

CONNECTOR STYLE
P=PIN
S=SOCKET

TERMINATION TYPE
A=.318" [8.08] FOOTPRINT

CONTACT FINISH/GOLD THICKNESS
NO DIGIT=STANDARD 15 MICRINCHES
[0.38 MICRONS] GOLD
G=50 MICRINCHES [1.27 MICRONS]
GOLD

MODIFIER
0=STANDARD

FILTER CAPACITANCE
D=50 pF 7=1200 pF
B=100 pF J=1500 pF
O=180 pF E=2200 pF
F=330 pF 9=5600 pF
1=470 pF 8=47000 pF
4=820 pF N=NO FILTERS
5=1000 pF

REFER TO AMPHENOL
CATALOGUE FOR FILTER
PERFORMANCE CHARACTERISTICS

MOUNTING
2=.120 [3.05] DIA THROUGH HOLE
3=#4-40 UNC SELF-LOCKING THREAD
4=#4-40 UNC THREAD
6=M3 x 0.5 THREAD
E=CODE 4 MOUNTING WITH #4-40
UNC HEX JACK SOCKET SUPPLIED.

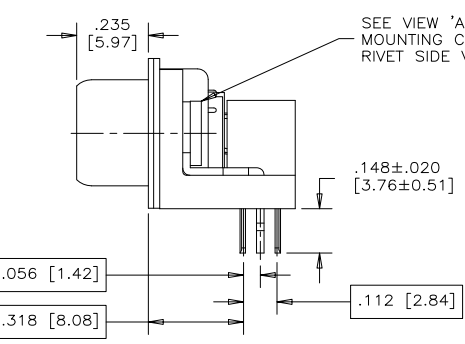
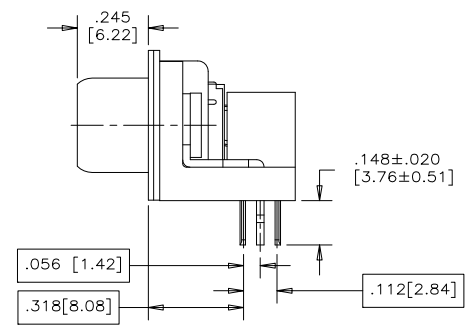
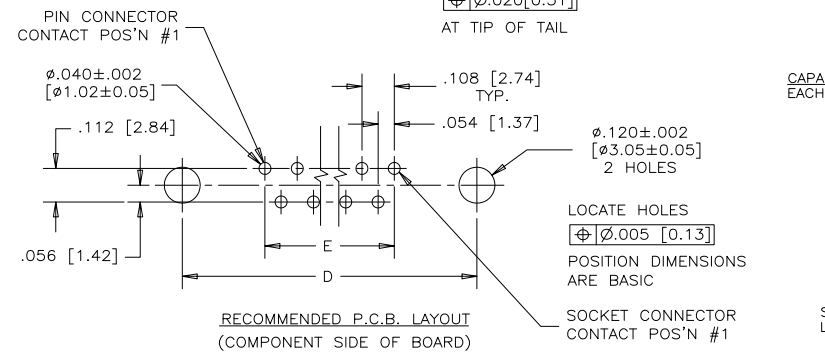
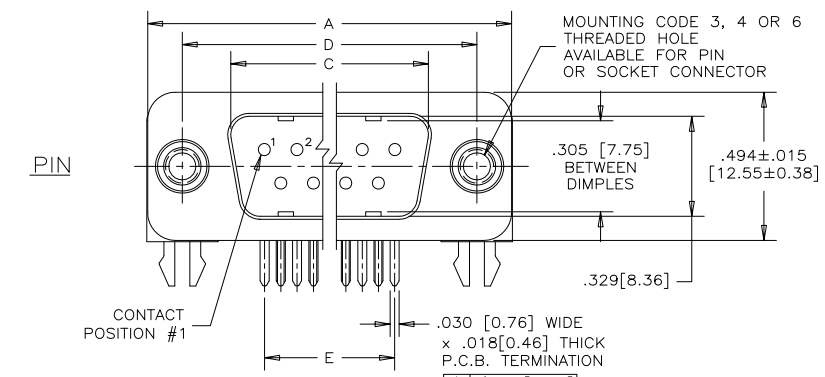
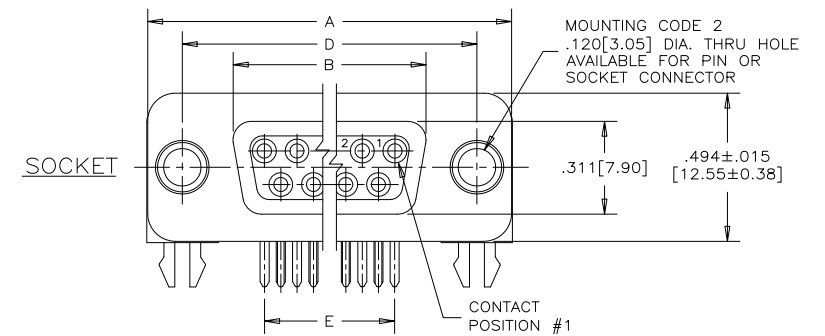

NOTES:

- MATERIALS: - SHELLS - TIN PLATED STEEL
- CONTACTS - PHOSPHOR BRONZE PLATED WITH GOLD OVER NICKEL ON THE MATING AREA AND TIN-LEAD ON THE TERMINALS
- INSULATOR - ENGINEERING THERMOPLASTIC, FLAMMABILITY RATING UL94V-0, BLACK
- CONTACT RESISTANCE: 15 MILLIOHMS MAXIMUM
- INSULATION RESISTANCE: 3000 MEGOHMS MINIMUM
- CURRENT RATING: 5 AMPS MAXIMUM
2 AMPS FILTERING MAXIMUM
- OPERATING TEMPERATURE: -40°C TO 85°C
- TOLERANCE UNLESS INDICATED OTHERWISE: ±.005 [0.13]
- MATERIAL FOR 9, 15 AND 25 SIZE IS HIGH TEMPERATURE RESISTANT AND CAN WITHSTAND 260°C FOR 60 SECONDS.
- CSA ELECTRICAL RATING: 200VDC, 5A MAX.

SIZE	STYLE	A±.015 [0.38]	B±.005 [0.13]	C±.005 [0.13]	D±.005 [0.13]	E BSC.
E09	PIN	1.213 [30.81]	-----	.666 [16.92]	.984 [24.99]	.432 [10.97]
	SOCKET		.643 [16.33]	-----		
A15	PIN	1.541 [39.14]	-----	.994 [25.25]	1.312 [33.32]	.756 [19.20]
	SOCKET		.971 [24.66]	-----		
B25	PIN	2.088 [53.04]	-----	1.534 [38.96]	1.852 [47.04]	1.304 [33.12]
	SOCKET		1.511 [38.38]	-----		
C37	PIN	2.729 [69.32]	-----	2.182 [55.42]	2.500 [63.50]	1.956 [49.68]
	SOCKET		2.159 [54.84]	-----		

CAPACITANCE SCHEMATIC EACH POSITION

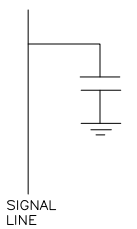

MATERIAL	DRAWN I.ESSAJEE	DATE 96/10/08
	DESIGNED K.LAMBIE	96/10/07
	CHECKED	
	I. E. APPRD.	
	Q. A. APPRD.	
	DWG. APPRD.	
	ENG. REL. NO.	
	REF.	
	DIMENSIONS ARE IN INCHES [mm]	CODE ID. NO. 03554

Amphenol Canada Corp.

TITLE
FCC17 FILTERED D-SUB, RIGHT ANGLE .318 [8.08] F/P, PIN & SOCKET - PLASTIC MTG BRACKET & BOARDLOCK

DWG C DRAWING NO. P-FCC17-XXXXA-XX0X REV. P

SCALE 3/1 WT. ----- SURF. ----- SHEET 1 OF 1

THIS DOCUMENT CONTAINS PROPRIETARY INFORMATION AND SUCH INFORMATION MAY NOT BE DISCLOSED TO OTHERS FOR ANY PURPOSE OR USED FOR MANUFACTURING PURPOSES WITHOUT WRITTEN PERMISSION FROM AMPHENOL CANADA CORP.