

REVISIONS				
SYM	ZONE	ECN, ERN NO.	DATE	APPRD.
A		PROPOSAL	05/10/12	L.CHAN

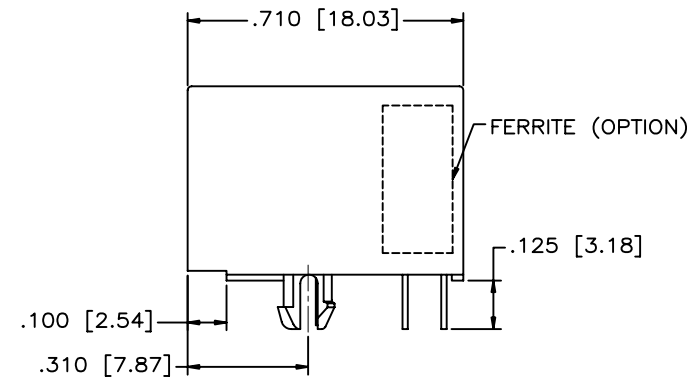

**NON-SHIELDED**  
(8 POSITION, 8 CONTACTS SHOWN)

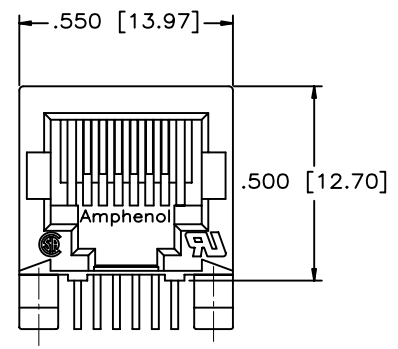
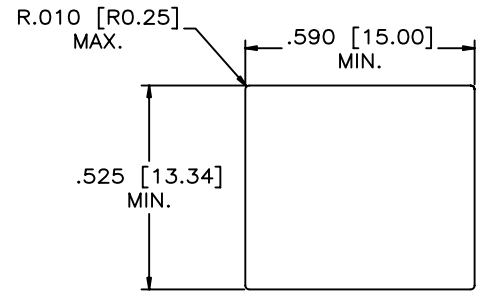

**RECOMMENDED PANEL CUTOUT**  
**SHIELDED**

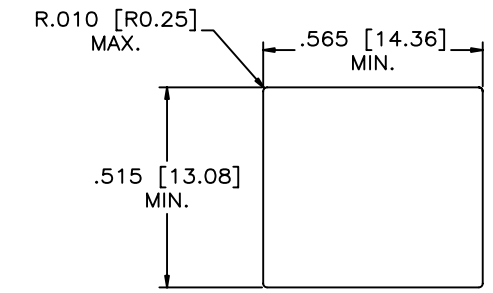

**RECOMMENDED PANEL CUTOUT**  
**NON-SHIELD**

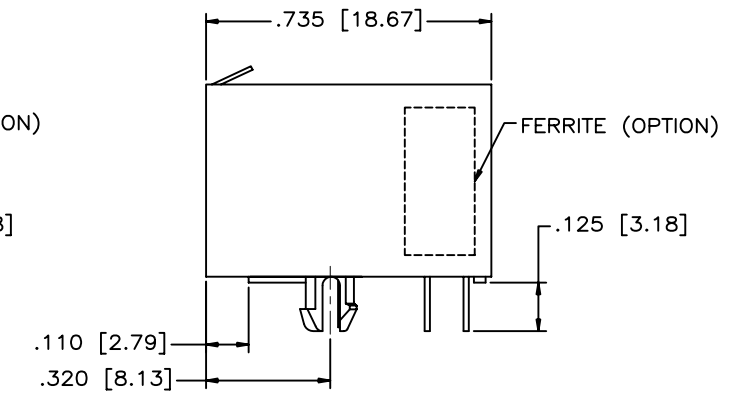
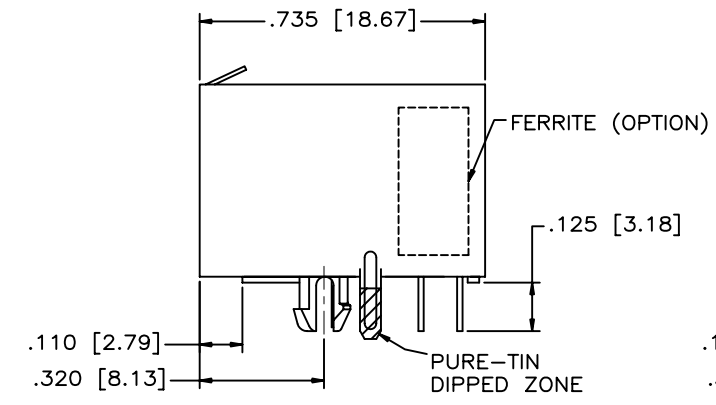
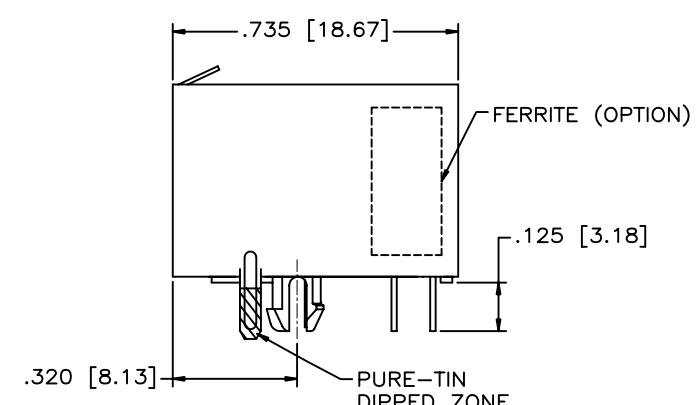
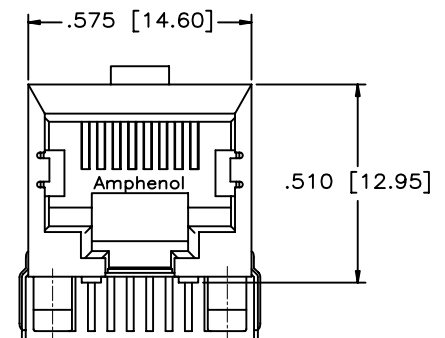

**SHIELDED**  
(8 POSITION, 8 CONTACTS SHOWN)

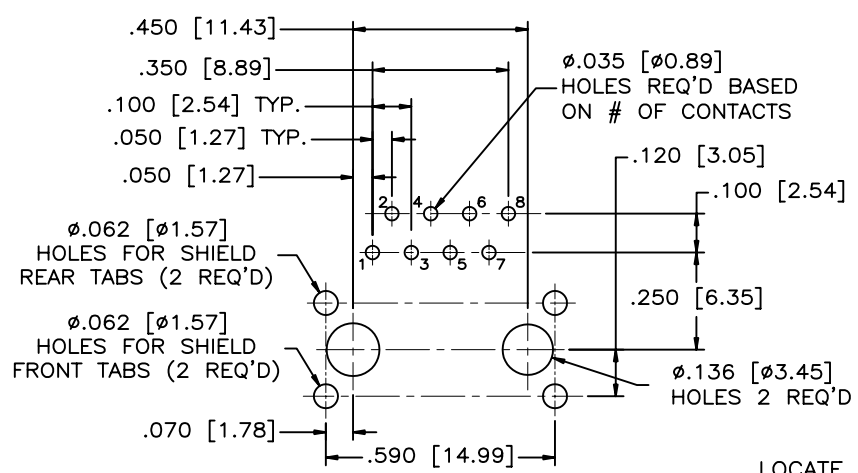

**RECOMMENDED P.C.B. LAYOUT**

LOCATE HOLES  
⊕ ⌀.005 [0.13]  
POSITION DIMENSIONS  
ARE BASIC

**FRJAE CONNECTOR NUMBER SYSTEM**

EXAMPLE: **F R J A E - X X X**  
SERIES \_\_\_\_\_

**CONNECTOR STYLE & POSITIONS**

4=RJ45 OR 8 POSITIONS  
6=RJ11 OR 6 POSITIONS

**OPTIONS**

0=NON FILTERED, NON SHIELDED  
1=FILTERED WITH FRONT TAIL SHIELD  
3=SHIELD (FRONT TAIL)  
4=FILTERED  
6=FILTERED WITH REAR TAIL SHIELD  
7=FILTERED WITH NON-TAIL SHIELD  
8=SHIELD (REAR TAIL)  
9=SHIELD (NON-TAIL)

**NO. OF CONTACTS**

8 - 8 POSITIONS  
6 - 6 POSITIONS  
4 - 4 POSITIONS  
2 - 2 POSITIONS  
C - 2 POSITIONS -(POS. 2 & 5, IN 6 POS.)  
                          -(POS. 3 & 6, IN 8 POS.)

**MATERIALS:**  
PLASTIC HOUSING: HIGH TEMPERATURE THERMOPLASTIC  
FLAMMABILITY RATING UL 94V-0

**CONTACTS:** PHOSPHOR BRONZE  
PLATING: 50 μ" [1.27 MICRONS]  
MIN. GOLD ON MATING SURFACES.  
50 μ" [1.27 MICRONS]  
MIN. NICKEL UNDERPLATE  
GOLD FLASH ON CONTACT TAILS.

**SHIELD:** COPPER ALLOY  
PLATING: NICKEL WITH PURE-TIN DIPPED PCB TAIL.

DRAWN PAULW	DATE 05/12/25
DESIGNED	
CHECKED CHIGOW	05/12/25
I. E. APPRD.	
Q. A. APPRD.	
DWG. APPRD.	
ENG. REL. NO.	
REF.	
DIMENSIONS ARE IN INCHES [mm]	CODE ID. NO. 03554

<b>Amphenol Canada Corp.</b>	
TITLE FRJAE ASSEMBLY, 6 POSITION & 8 POSITION, WITH OR WITHOUT FERRITES, SINGLE PORT, HIGH TEMP. MATERIAL SHIELDED OR UNSHIELDED - RoHS COMPLIANT	
DWG	DRAWING NO. P-FRJAE-XXX
REV.	A
SCALE	WT. ----- SURF. ----- SHEET 1 OF 1

THIS DOCUMENT CONTAINS PROPRIETARY INFORMATION AND SUCH INFORMATION MAY NOT BE DISCLOSED TO OTHERS FOR ANY PURPOSE OR USED FOR MANUFACTURING PURPOSES WITHOUT WRITTEN PERMISSION FROM AMPHENOL CANADA CORP.