

This document is the property of Amphenol Corporation and is delivered on the express condition that it is not to be disclosed, reproduced or used, in whole or in part, for manufacture or sale by anyone other than Amphenol Corporation without its prior consent, and that no right is granted to disclose or to use any information in this document.

** THIS PRODUCT DIDN'T HAVE ENVIRONMENT- RELATED SUBSTANCES PER MATERIALS SPECIFICATION #MS-S001, LEVEL 1. WHEN THE TIME SET SCHEDULE OF LEVEL 2 IS EXPIRY, THE SUBSTANCES SHALL NOT BE CONTAINED WITH THIS PRODUCT.

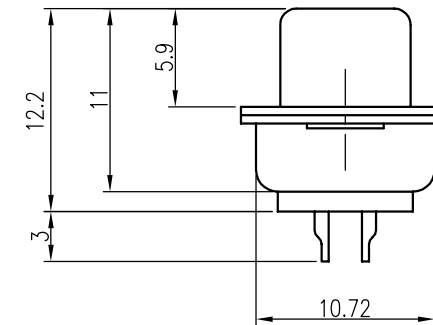
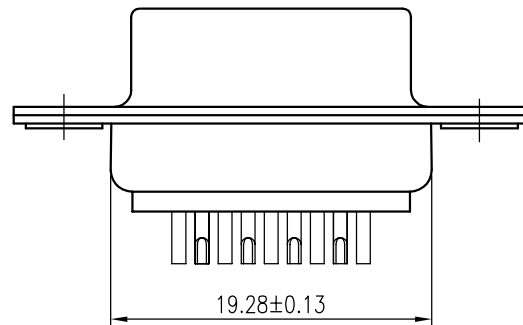
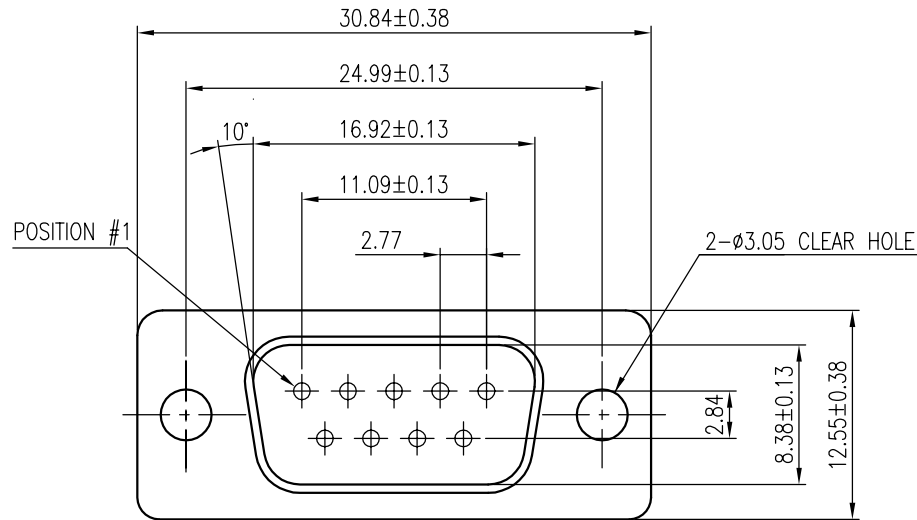

CUSTOMER DRAWING ORIGINAL

REVISIONS				
SYM	ECN No.	DESCRIPTION	DATE	APPROVED
A		RELEASE FOR RoHS	05/04/2005	Raymond Chao



NOTES:

- FRONT & REAR SHELL FINISH: TIN PLATED
- CONTACTS FINISH: FLASH GOLD PLATED
- INSULATOR: PBT, GLASS FIBER FILLED, UL 94V-0, COLOR- BLACK
- THIS PRODUCT DOESN'T CONTAIN ENVIRONMENTAL HAZARDOUS MATERIALS PER MATERIAL SPECIFICATION #MS-S001.

TOLERANCE m/m	APPROVALS	DATE	TITLE		Amphenol®	
x. ±0.30	DRAWN Sondra Sang	05/04/05	G17S SERIES SOLDER-POT TERMINATION PLUG, 9-POSITION		Amphenol Corporation Amphenol Taiwan Corporation	
x.x ±0.25	CHECKED Laura Su	05/04/05				
x.xx ±0.15	APPROVED Ken Lin for	05/04/05				
x.xxx ±0.08			SCALE	N.A.	SHEET	1 OF 1
ANGULAR ±2°			SIZE	PART NO.	DRAWING NO.	REV.
UNLESS OTHERWISE SPECIFIED	 	UNIT MM	A4	G17S 0910 110 EU	DSUB-G17S0910110EU-25	A