

This document is the property of Amphenol Corporation and is delivered on the express condition that is not to be disclosed, reproduced or used, in whole or in part, for manufacture or sale by anyone other than Amphenol Corporation without its prior consent, and that no right is granted to disclose or to use any information in this document.

The marking on this product doesn't contain environmental hazardous material and must follow one or more specifications per Material Specification SS-00259 for Sony GP compliant or per directive 2002/95/EC for RoHS compliant or per IEC 61249-2-21 for Halogen Free compliant.



ORIGINAL



REVISIONS				
SYM	ECN No.	DESCRIPTION	DATE	BY
A		RELEASE TO PRODUCTION	07/02/2010	Sondra Sang
B	NE-10119	MODIFIED THE FRONT SHELL PLATING	07/28/2010	Sondra Sang
C	NE-10123	MODIFIED PNS	08/06/2010	Sondra Sang
D	NE-10161	MODIFIED MATERIAL	10/06/2010	Sondra Sang

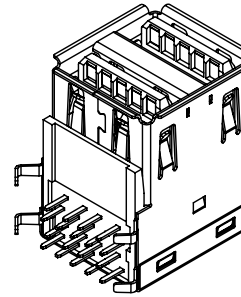
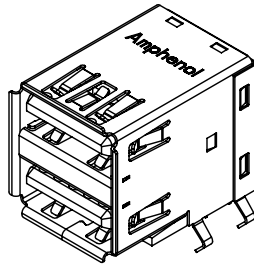
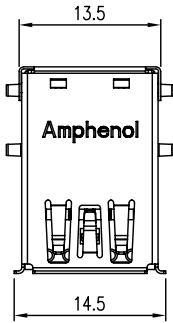

PIN #	PIN #	SIGNAL NAME
1	10	VBUS
2	11	D-
3	12	D+
4	13	GND
5	14	SSRX-
6	15	SSRX+
7	16	GND_DRAIN
8	17	SSTX-
9	18	SSTX+
SHELL		SHIELD

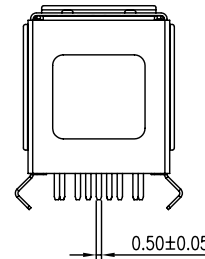
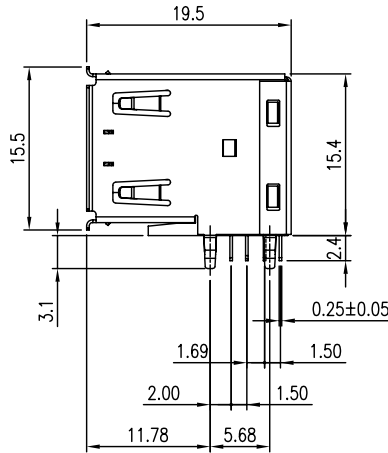
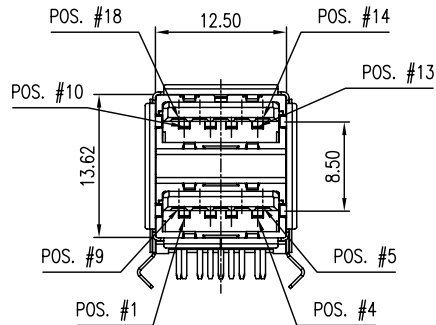

PIN ASSIGNMENT

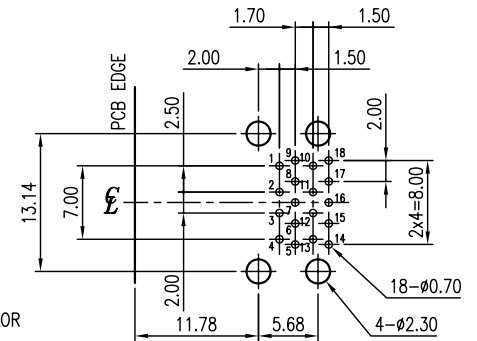

RECOMMENDED PCB LAYOUT- TOP VIEW  
(GENERAL TOLERANCE: ±0.05)

NOTES:

- HOUSING: HIGH TEMPERATURE THERMOPLASTIC, UL 94V-0 OR 94H-B, COLOR- BLUE (PANTONE 300C)
- BOTTOM COVER: HIGH TEMPERATURE THERMOPLASTIC, UL 94V-0, COLOR- BLUE (PANTONE 300C)
- CONTACT: COPPER ALLOY, 0.25mm THICKNESS, 30µ" MIN. GOLD or 2µ" MIN. GOLD +30µ" MIN. Ni-Pd PLATED ON CONTACT AREA, 120µ" MIN. MATTE TIN PLATED ON SOLDERING TAIL, 80µ" MIN. NICKEL UNDER-PLATED OVERALL
- FRONT SHELL: STAINLESS STEEL, 0.25mm THICKNESS, 50µ" MIN. NICKEL PLATED OVER ALL
- MIDDLE SHELL: STAINLESS STEEL, 0.25mm THICKNESS,
- REAR SHELL: STAINLESS STEEL, 0.2mm THICKNESS,
- THIS PRODUCT DOESN'T CONTAIN ENVIRONMENTAL HAZARDOUS MATERIALS PER DIRECTIVE 2002/95/EC FOR RoHS AND PER IEC 61249-2-21 FOR HALOGEN FREE COMPLIANT.

PART NUMBER:  
GSB3 112 X X HR

- CONTACT FINISH — INSULATOR AND COLOR
- 3: 30µ" GOLD 1: LCP, Blue
  - 4: 2µ" GOLD+30µ" Ni-Pd 4: Nylon 9T, Blue

TOLERANCE	APPROVALS	DATE	TITLE	UNIT	SIZE	PART No.
X. ±0.30	DRAWN Sondra Sang	10/06/10	USB 3.0 CONNECTOR STANDARD A, STACKED, R/A DIP TYPE	mm	A3	Amphenol® Amphenol Corporation Amphenol Taiwan Corporation
X.X ±0.20	CHECKED Chenny Yeh	10/06/10				
X.XXX ±0.10	APPROVED Hank Hsu	10/06/10				
ANGULAR ±1°	DWG TYPE CUST DWG	PROJECT CODE T510	UNIT mm	SCALE NA	SHEET 1 OF 1	PART No. GSB3 112 XX HR
UNLESS OTHERWISE SPECIFIED						DWG No. GSB311231HR REV. D