

This document is the property of Amphenol Corporation and is delivered on the express condition that is not to be disclosed, reproduced or used, in whole or in part, for manufacture or sale by anyone other than Amphenol Corporation without its prior consent, and that no right is granted to disclose or to use any information in this document.

The marking on this product doesn't contain environmental hazardous material and must follow one or more specifications per Material Specification SS-00259 for Sony GP compliant or per directive 2002/95/EC for RoHS compliant or per IEC 61249-2-21 for Halogen Free compliant.



ORIGINAL



REVISIONS				
SYM	ECN No.	DESCRIPTION	DATE	BY
A		RELEASE TO PRODUCT	06/28/2010	Sondra Sang
B	NE-10123	MODIFIED PNS	08/06/2010	Sondra Sang

PART NUMBER:
GSB3 171 X X HR

CONTACT FINISH INSULATOR AND COLOR
 3: 30μ" GOLD 1: LCP, Blue
 4: 2μ" GOLD+30μ" Ni-Pd 4: Nylon, Blue

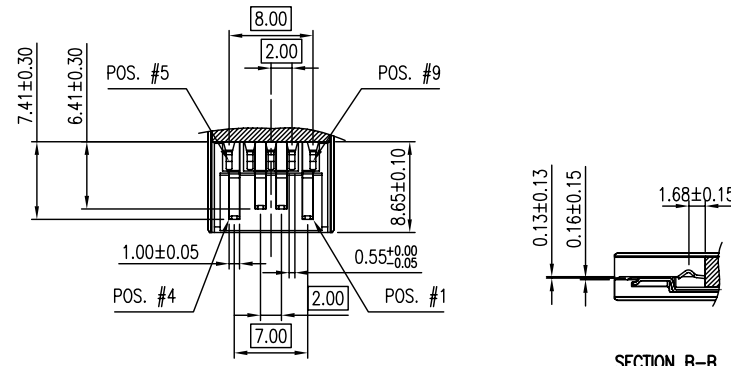
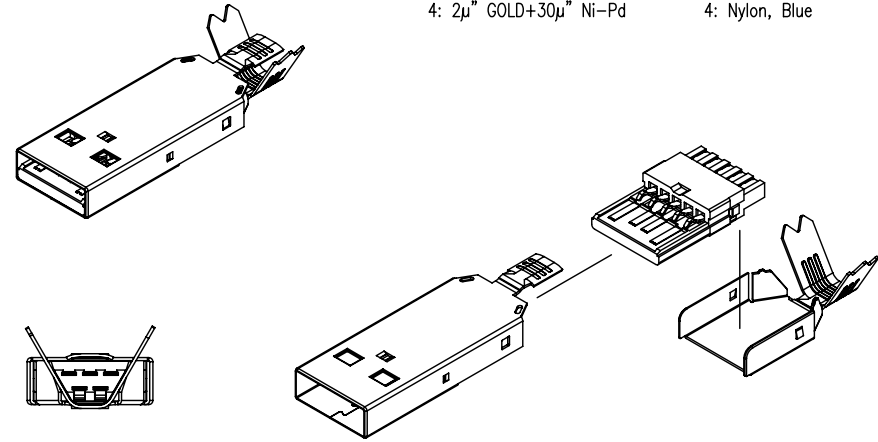
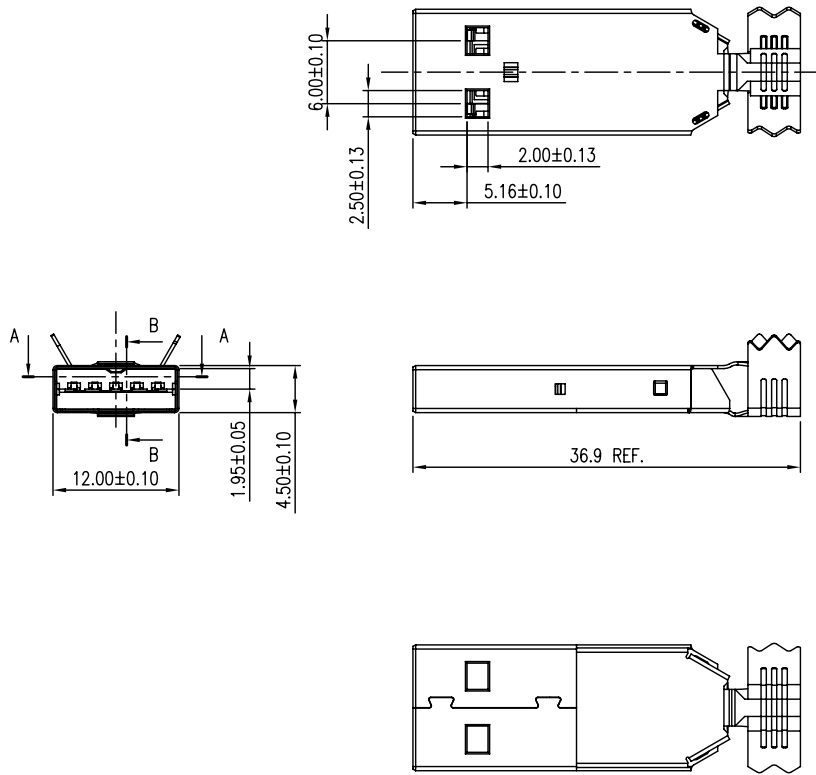

- NOTES:
- HOUSING: HIGH TEMPERATURE THERMOPLASTIC, UL 94V-0, COLOR- BLUE
 - USB TERMINAL: COPPER ALLOY, 0.25mm THICKNESS, 30μ" MIN. GOLD or 2μ" MIN. GOLD +30μ" MIN. Ni-Pd PLATED ON CONTACT AREA, 100μ" MIN. MATTE TIN ON SOLDERING TAIL, 50μ" MIN. NICKEL UNDER-PLATED OVERALL
 - METAL SHELL: STAINLESS STEEL, 0.3mm THICKNESS
 - THIS PRODUCT DOESN'T CONTAIN ENVIRONMENTAL HAZARDOUS MATERIALS PER DIRECTIVE 2002/95/EC FOR RoHS AND PER IEC 61249-2-21 FOR HALOGEN FREE COMPLIANT.

TOLERANCE	APPROVALS	DATE	TITLE	UNIT	SIZE	WARRANTY	REV.
X. ±0.30 X.X ±0.20 X.XX ±0.10 X.XXX ±0.10	DRAWN Sondra Sang	08/06/10	USB 3.0 CONNECTOR STANDARD A, PLUG CABLE TYPE, OVERMOLD	mm	A3	PART No. GSB3 171 XX HR	REV. B
	CHECKED Chenny Yeh	08/06/10					
	APPROVED Hank Hsu	08/06/10					
ANGULAR ±1°	DWG TYPE CUST DWG	PROJECT CODE T506	SCALE NA	SHEET 1 OF 1	DWG No. GSB317131HR		
UNLESS OTHERWISE SPECIFIED							

Amphenol®
 Amphenol Corporation
 Amphenol Taiwan Corporation