

This document is the property of Amphenol Corporation and is delivered on the express condition that it is not to be disclosed, reproduced or used, in whole or in part, for manufacture or sale by anyone other than Amphenol Corporation without its prior consent, & that no right is granted to disclose or to use any information in this document.

# Customer drawing

REVISIONS				
SYM	ECN	DESCRIPTION	DATE	APPROVED
1	HK--	New release	09/05/07	IP
2	HK--	Update the drawing	11/05/08	IP
3	HK--	Define the plating spec	05/28/14	IP

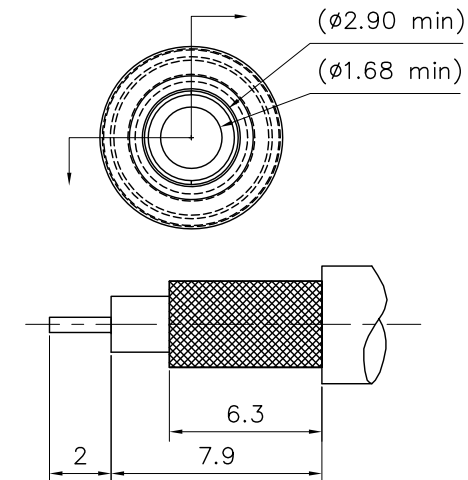
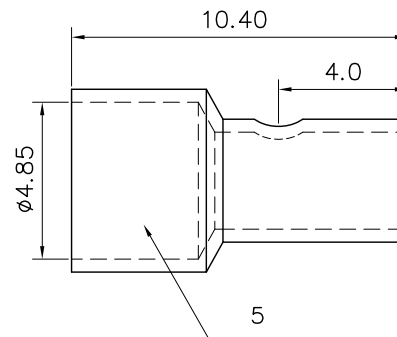
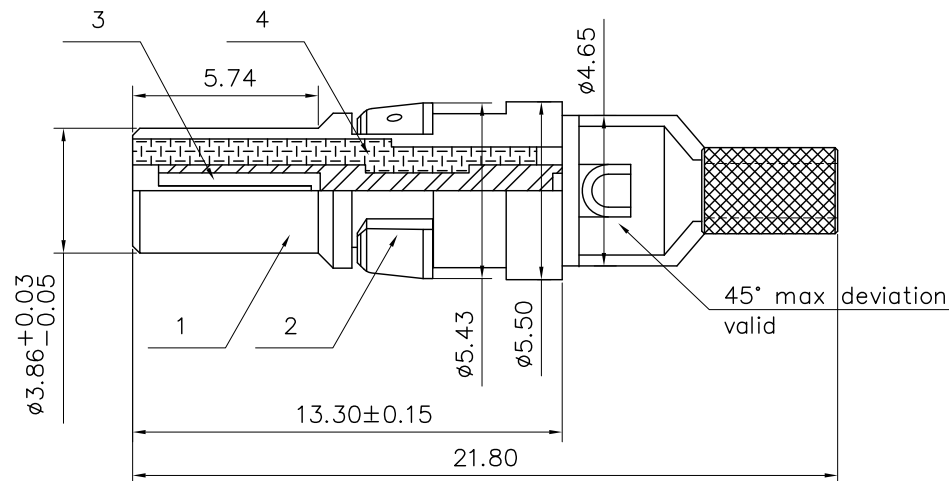

Trim cable



## MECHANICAL

1. Materials: refer to the table
2. Finish: refer to the table

## ELECTRICAL :

Impedance: 50 Ohms Nominal  
 Withstand voltage: 1000V,50HZ,rms.  
 Insulation Resistance: 5000 Megaohms Minimum  
 Contact Resistance: (Milliohms maximum)  
 Center Contact: 5.0  
 Outer Contact: 3.0  
 Working voltage: AC 250V

## ENVIRONMENTAL

Operating Temperature range : -55 °C up to +125°C

5	ferrule	brass,4u" gold over 50u" min. nickel
4	insulator	PTFE, Color white
3	center contact	phosphor bronze, 30u" min. gold over 50u" min. nickel
2	ring	thermoplastic, Color black
1	outer contact	brass,4u" gold over 50u" min. nickel
Sequence	Material	Remark

UNLESS OTHERWISE SPECIFIED TOLERANCES		APPROVAL		DATE	Amphenol Amphenol East Asia Limited TITLE Straight shielded contacts Crimp ferrule
U.S. METRIC		DRAWN	Feliz Liu	05/28/14	
.X +/- 0.25		CHECKED	Tony Tang	05/28/14	
.XX +/- 0.15		CHECKED			
.XXX +/- 0.10		DRAWING FILE :			SIZE DRAWING NO.
FRACTIONS +/- 2'		ANGLE OF PROJECTION			A4 L17DM537405001
ANGLES +/-		REMOVE SHARP EDGES			REV.
DIMENSIONS		U.S. INCHES			3
U.S. INCHES		METRIC MM			SCALE NONE
METRIC MM		SHEET 1 OF 1			