

This document is the property of Amphenol Corporation and is delivered on the express condition that it is not to be disclosed, reproduced or used, in whole or in part, for manufacture or sale by anyone other than Amphenol Corporation without its prior consent, & that no right is granted to disclose or to use any information in this document.

Customer drawing

REVISIONS				
SYM	ECN	DESCRIPTION	DATE	APPROVED
1			09/05/08	

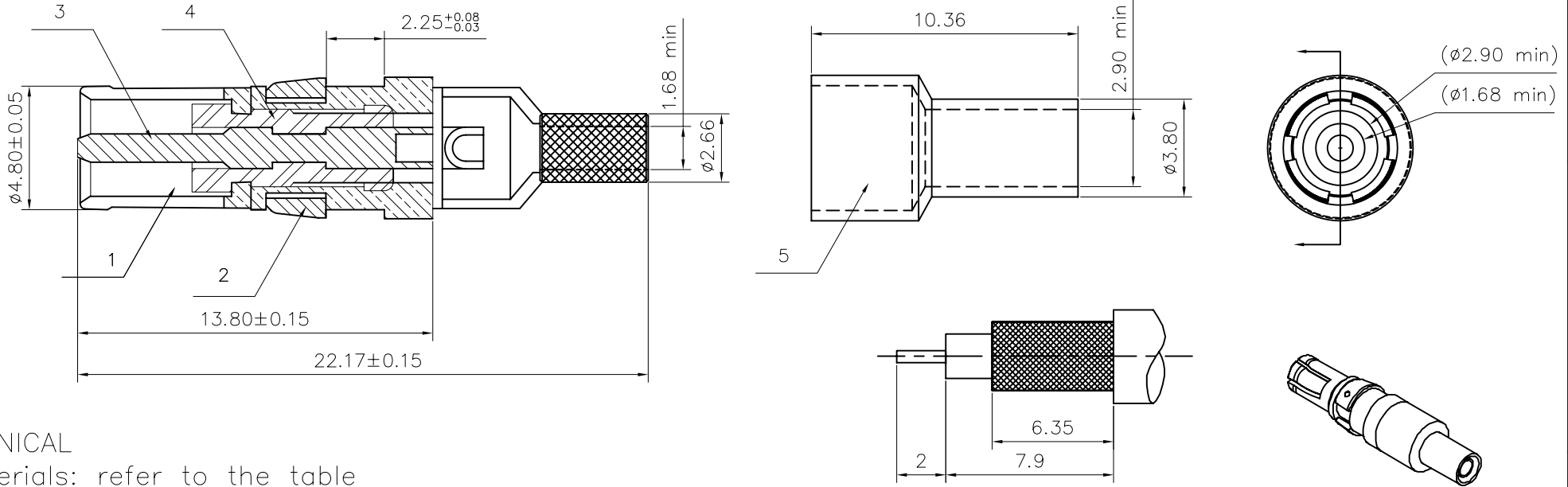

MECHANICAL

1. Materials: refer to the table
2. Finish: refer to the table

ELECTRICAL :

Impedance: 50 Ohms Nominal
 Frequency Range: 0 to 5.0 GHz
 Insulation Resistance: 5000 Megaohms Minimum
 Contact Resistance: (Milliohms maximum)
 Center Contact: 5.0
 Outer Contact: 3.0
 Voltage Standing Wave Ratio: 0 to 5.0 GHz

ENVIRONMENTAL

Operating Temperature range : -55 °C up to +125°C
 Vibration: MIL-STD-202, Method 204, Test Condition D
 Shock: MIL-STD-202, Method 213, Test Condition I
 Corrosion Resistance: MIL-STD-202, Method 101, Test Condition B



Trim cable

5	ferrule	brass, gold over 50u" min. nickel
4	insulator	PTFE, Color white
3	center contact	phosphor bronze, 30u" min. gold over 50u" min. nickel
2	ring	thermoplastic, Color black
1	outer contact	brass, gold over 50u" min. nickel
Sequence	Material	Remark

UNLESS OTHERWISE SPECIFIED TOLERANCES		APPROVAL		DATE
U.S.	METRIC	DRAWN	Checked	
.X +/-	0.20	Mary.ma		09/05/08
.XX +/-	0.10			
.XXX +/-	0.05			
FRACTIONS +/-				
ANGLES +/-	2'			
FOR MATERIALS AND FINISHES SEE NOTES		DRAWING FILE :		
REMOVE SHARP EDGES		ANGLE OF PROJECTION		
DIMENSIONS				
U.S.	INCHES			
METRIC	MM			

Amphenol®		
TITLE Straight shielded contacts ferrule		
SIZE	DRAWING NO.	REV.
A4	C L17DM53742-5001	1
SCALE	NONE	SHEET 1 OF 1