

This document is the property of Amphenol Corporation and is delivered on the express condition that it is not to be disclosed, reproduced or used, in whole or in part, for manufacture or sale by anyone other than Amphenol Corporation without its prior consent, & that no right is granted to disclose or to use any information in this document.

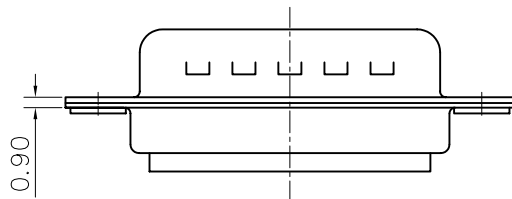
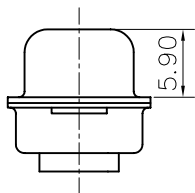
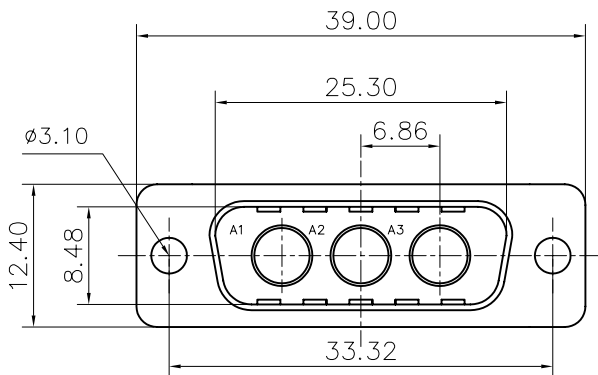

Customer drawing

REVISIONS				
SYM	ECN	DESCRIPTION	DATE	APPROVED
1			01/24/08	IP

D-SUB TECHNICAL DATA

SHELL : Steel 2.5um(100u") min tin over 1.25um(50u") min nickel
 BODY : Glass filled thermoplastic.
 Flame retardant to UL94 V-0 Color Black

ELECTRICAL : Voltage rating 300 V RMS at 50 Hz
 Withstanding Voltage >1000 V RMS at 50 Hz for one minute
 Insulation resistance >5000 M Ohms

CLIMATIC : Temperature range -55 °C up to 155°C
 Damp heat 56 days(40 °C-95% HR)

MARKING : Amphenol-...(Series No.)
 Commercial reference
 Manufacturing date

PRODUCT CODE

L 717TW A 3W3 P

L: RoHS Compliance

717TW: tinned shell with dimples

Shell Size :A

Contact type:
S:Female
P: Male

Configuration: 3W3

UNLESS OTHERWISE SPECIFIED TOLERANCES		APPROVAL	DATE
U.S.	METRIC	DRAWN	DATE
.X +/-	0.50	Helen Jiang	07/03/07
.XX +/-	0.30	CHECKED	Uk.wang 07/03/07
.XXX +/-	0.20	CHECKED	
FRACTIONS +/-			
ANGLES +/-	2'		
FOR MATERIALS AND FINISHES SEE NOTES		DRAWING FILE : drawing\Draw\ML717TWASWSP	
REMOVE SHARP EDGES		ANGLE OF PROJECTION	
DIMENSIONS			
U.S. INCHES	METRIC MM		

Amphenol		
TITLE		
Hybrid connector, TW series		
SIZE	DRAWING NO.	REV.
A4	C L717TWA3W3P	1
SCALE	NONE	SHEET 1 OF 1