

This document is the property of Amphenol Corporation and is delivered on the express condition that it is not to be disclosed, reproduced or used, in whole or in part, for manufacture or sale by anyone other than Amphenol Corporation without its prior consent, & that no right is granted to disclose or to use any information in this document.

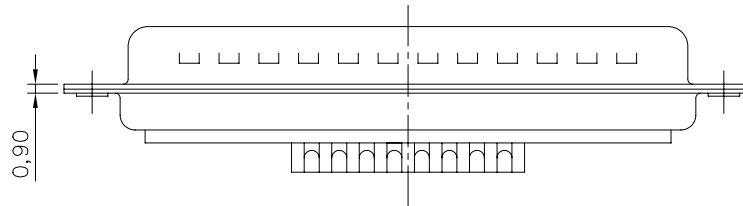
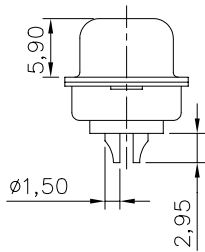
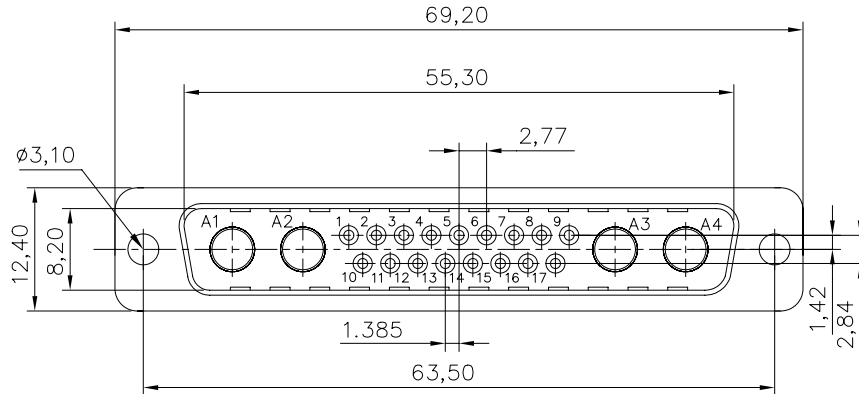

Customer drawing

REVISIONS				
SYM	ECN	DESCRIPTION	DATE	APPROVED
1			12/26/07	

**D-SUB TECHNICAL DATA**

SHELL : Steel 2.5um(100u") min tin over 1.25um(50u") min nickel  
 BODY : Glass filled thermoplastic.  
 Flame retardant to UL94 V-0 Color Black  
 CONTACTS : Brass, 15u" min gold over 50u" min nickel  
 ELECTRICAL : Voltage rating 300 V RMS at 50 Hz  
 Current rating 7.5A  
 Withstanding Voltage >1000 V RMS at 50 Hz for one minute  
 Insulation resistance >5000 M Ohms  
 Contact resistance 20 mOhms max.  
 CLIMATIC : Temperature range -55 °C up to 155°C  
 Damp heat 56 days(40 °C-95% HR)  
 MARKING : Amphenol...(Series No.)  
 Commercial reference  
 Manufacturing date

**PRODUCT CODE**

**L 717TW C 21WA4 P**

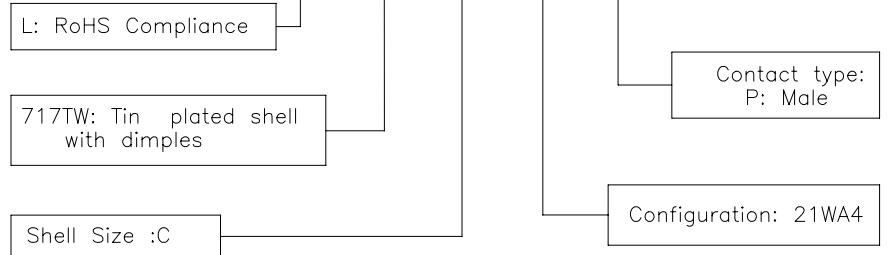

UNLESS OTHERWISE SPECIFIED TOLERANCES		APPROVAL		DATE
U.S.	METRIC	DRAWN	Christine.cui	12/26/07
.X	+/- 0.50	CHECKED	lik.wang	12/26/07
.XX	+/- 0.30	CHECKED		
.XXX	+/- 0.20			
FRACTIONS	+/-			
ANGLES	+/- 2°			
FOR MATERIALS AND FINISHES SEE NOTES		DRAWING FILE :		
REMOVE SHARP EDGES		ANGLE OF PROJECTION		
DIMENSIONS				
U.S.	INCHES			
METRIC	MM			

Amphenol		
TITLE Hybrid connector, TW series		
SIZE	DRAWING NO.	REV.
A4	C L717TWC21WA4P	1
SCALE	NONE	SHEET 1 OF 1