

This document is the property of Amphenol Corporation and is delivered on the express condition that it is not to be disclosed, reproduced or used, in whole or in part, for manufacture or sale by anyone other than Amphenol Corporation without its prior consent, & that no right is granted to disclose or to use any information in this document.

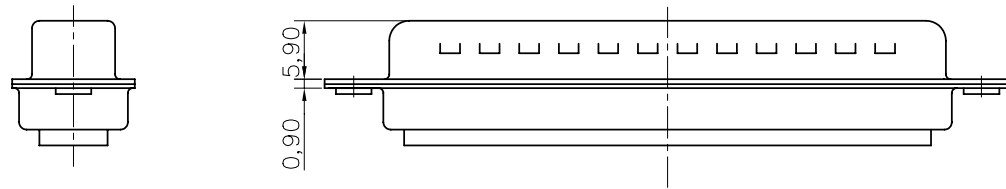
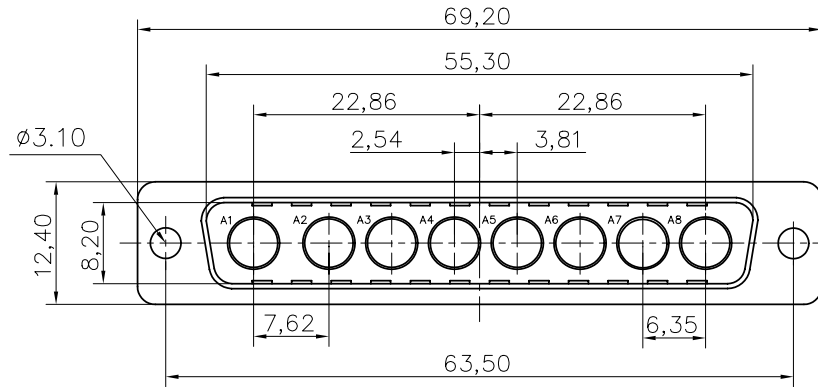

# Customer drawing

REVISIONS				
SYM	ECN	DESCRIPTION	DATE	APPROVED
1			04/08/08	

## D-SUB TECHNICAL DATA

SHELL : Steel 2.5um(100u") min tin over 1.25um(50u") min nickel  
 BODY : Glass filled thermoplastic.  
 Flame retardant to UL94 V-0 color black  
 ELECTRICAL : Withstanding Voltage >1000 V RMS at 50 Hz for one minute  
 Insulation resistance >5000 M Ohms  
 CLIMATIC : Temperature range -55 °C up to 155°C  
 Damp heat 56 days(40 °C-95% HR)  
 MARKING : Amphenol...(Series No.)  
 Manufacturing date  
 Commercial reference

### PRODUCT CODE

## L 717TW C 8W8 P

L: RoHS Compliance

Contact type:  
P: Male

Configuration:8W8

717TW: Tin plated shell  
with dimples

Shell Size :C

UNLESS OTHERWISE SPECIFIED		APPROVAL		DATE	Amphenol	
TOLERANCES		DRAWN	chrstina.cui	04/08/08		
	U.S.	METRIC	CHECKED	tk.wang	04/08/08	TITLE Hybrid connector, TW series
.X	+/-	0.50	CHECKED			
.XX	+/-	0.30				
.XXX	+/-	0.20				
FRACTIONS	+/-					
ANGLES	+/-	2'				
FOR MATERIALS AND FINISHES SEE NOTES		DRAWING FILE :				
REMOVE SHARP EDGES		ANGLE OF PROJECTION				
DIMENSIONS						
U.S.	INCHES					
METRIC	MM	SIZE	DRAWING NO.	REV.		
		A4	C L717TWC8W8P	1	SCALE	NONE
				SHEET 1 OF 1		