

This document is the property of Amphenol Corporation and is delivered on the express condition that it is not to be disclosed, reproduced or used, in whole or in part, for manufacture or sale by anyone other than Amphenol Corporation without its prior consent, & that no right is granted to disclose or to use any information in this document.

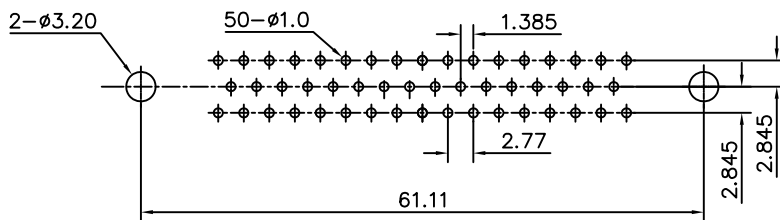

RECOMMENDED P.C.B LAYOUT
(TOLERANCE +/-0.03)

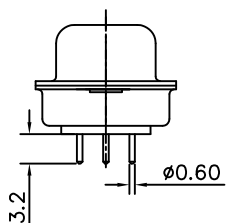
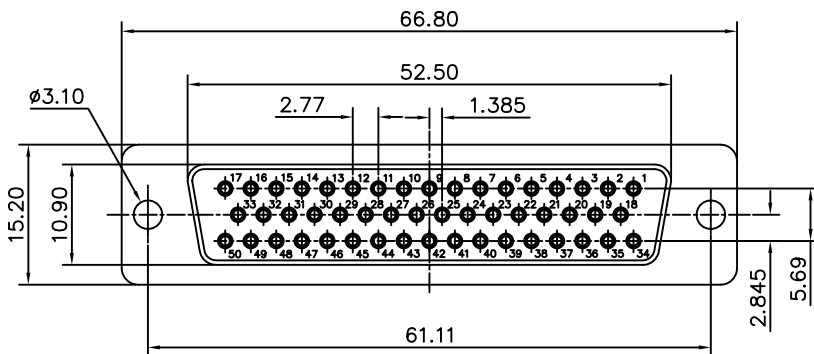

Customer drawing

REVISIONS				
SYM	ECN	DESCRIPTION	DATE	APPROVED
1			09/02/08	

D-SUB TECHNICAL DATA

SHELL: Steel, 100u" min tin over 50u" min nickel
 BODY: Glass filled thermoplastic.
 Flame retardant to UL94 V-0 Color Black
 CONTACTS: Brass, 0.1um (4u") min gold over 1.25um (50u") min nickel
 ELECTRICAL: Voltage rating 300 V Rms to 50 Hz
 Current rating 7.5A
 Withstanding Voltage >1000 V Rms to 50 Hz for one minute
 Insulation resistance >5000 M Ohms
 Contact resistance 20 mOhms max.
 CLIMATIC: Temperature range -55 °C up to 125°C
 MARKING: Amphenol...(Series No.)
 Commercial reference
 Manufacturing date

PRODUCT CODE

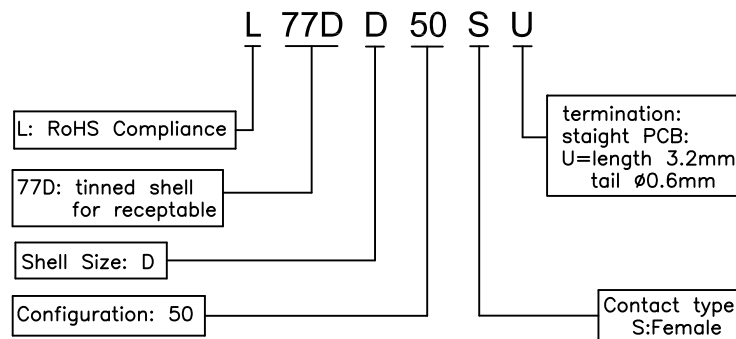

UNLESS OTHERWISE SPECIFIED TOLERANCES U.S. METRIC .X +/- 0.50 .XX +/- 0.30 .XXX +/- 0.20 FRACTIONS +/- ANGLES +/- 2° FOR MATERIALS AND FINISHES SEE NOTES REMOVE SHARP EDGES DIMENSIONS U.S. INCHES METRIC MM	APPROVAL	DATE
	DRAWN Mary.ma	09/02/08
	CHECKED Wk.wang	09/02/08
	CHECKED	
	DRAWING FILE :	
	ANGLE OF PROJECTION	

Amphenol®		
TITLE Machined contacts connector, D series		
SIZE	DRAWING NO.	REV.
A4	C L77DD50SU	1
SCALE	NONE	SHEET 1 OF 1