

REVISIONS				
REV.	EAR	DESCRIPTION	DATE	APPROVED
F	13741	NOTE UPDATES	JUL06/10	KL

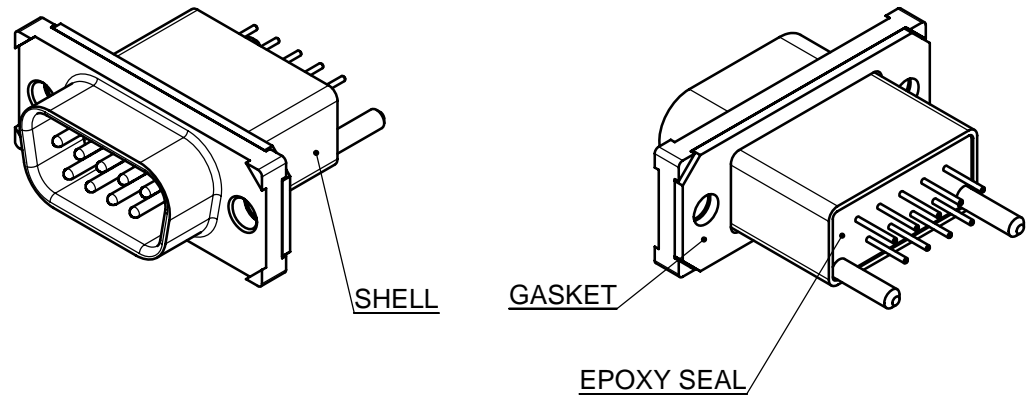

MDB-E09PA-765 IS SHOWN

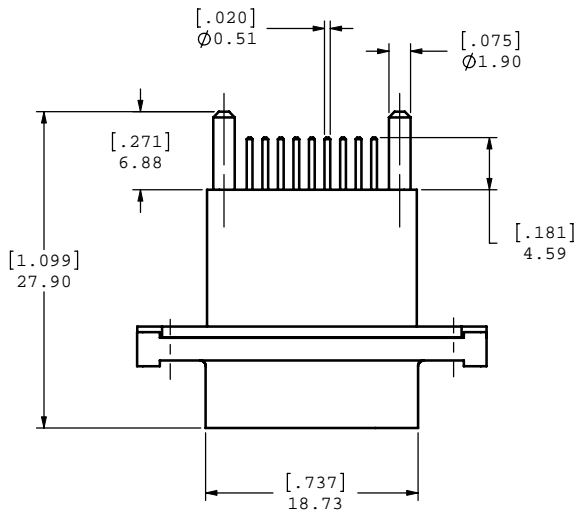
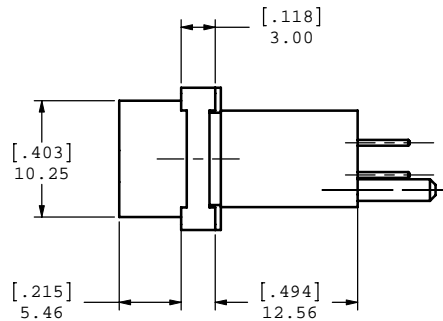
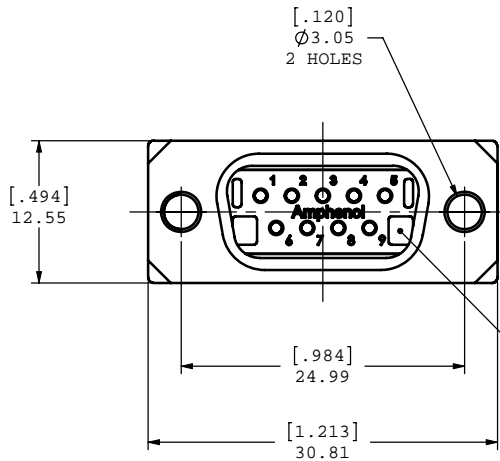

HOUSING

NOTES:

- MATERIAL:**
 - SHELL: ZINC ALLOY WITH 50 MICRO INCH MINIMUM NICKEL PLATING,
 - CONTACTS: COPPER ALLOY 30 MICRO INCH GOLD OVER 50 MICRO INCH NICKEL PLATING,
 - HOUSING: THERMOPLASTIC POLYESTER RESIN,
 - GASKET: SILICONE RUBBER,
 - SCREWS: STAINLESS STEEL,
 - DUST COVER: SILICONE RUBBER.
- FEATURES:** SEALED CONNECTOR IN THE MATED AND UNMATED CONDITIONS.
- OPERATING TEMPERATURE:** -40°C TO +105°C.
- ENVIRONMENT PERFORMANCE:** IP67.
- CONNECTOR IS ROHS COMPLIANT PER EU DIRECTIVE 2002/95/EC AND AMENDMENTS.**
- PART IS UL94V-0 FLAMMABILITY COMPLIANT.**
- PART NUMBER FOR ORDER:**
 - MDB-E09PA-760 - WITH DUST COVER AND SCREWS,
 - MDB-E09PA-765 - NO DUST COVER AND SCREWS.



UNLESS OTHERWISE SPECIFIED DIMENSIONS ARE IN MILLIMETER TOLERANCES ARE:		APPROVALS	DATE	Amphenol Canada Corp.	
DECIMALS	ANGLES	DRAWN	OCT06/06		
.XX ±.10	± 1°	S.SEMENOV	OCT06/06	TITLE RUGGED 9 PIN, D-SUB CONNECTOR, VERTICAL MOUNT	
.X ±.25		DESIGNED	OCT06/06	SIZE C	DWG. NO. P-MDB-E09PA-76X
MATERIAL AND FINISH		S.SEMENOV		SCALE 3:1	PROJECT MDB
REF.		CHECKED		REVISIONS	SHEET 1 OF 2
CODE IDENT. NO.		QA APP'D			
		IE APP'D			
		DWG APP'D	OCT06/06		
		A.GREEN			

DO NOT SCALE DRAWING
THIS DOCUMENT CONTAINS PROPRIETARY INFORMATION AND SUCH INFORMATION MAY NOT BE DISCLOSED TO OTHERS FOR ANY PURPOSE OR USED FOR MANUFACTURING PURPOSES WITHOUT PERMISSION FROM AMPHENOL CANADA CORP.

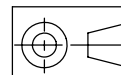

REVISIONS				
REV.	EAR	DESCRIPTION	DATE	APPROVED
F	13741	NOTE UPDATES	JUL06/10	KL

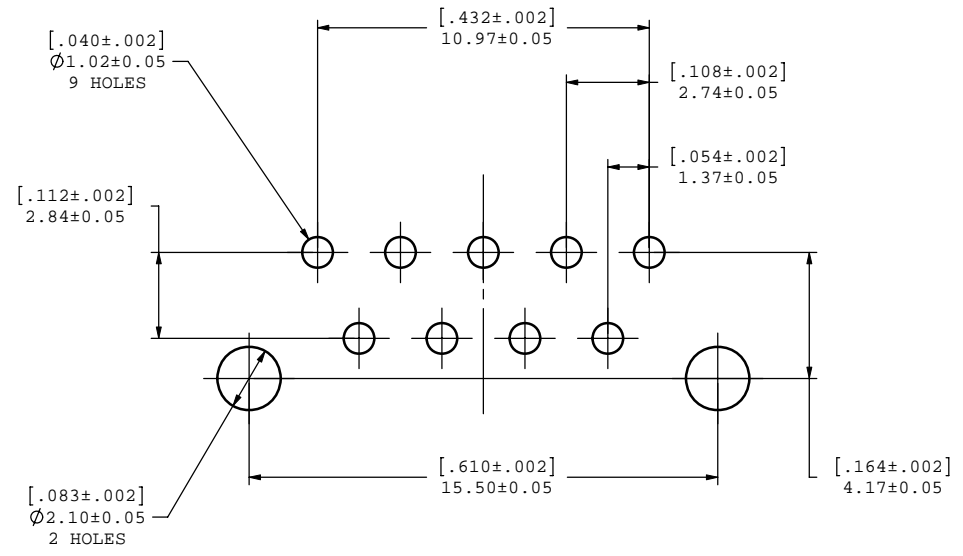

RECOMMENDED P.C.B. LAYOUT

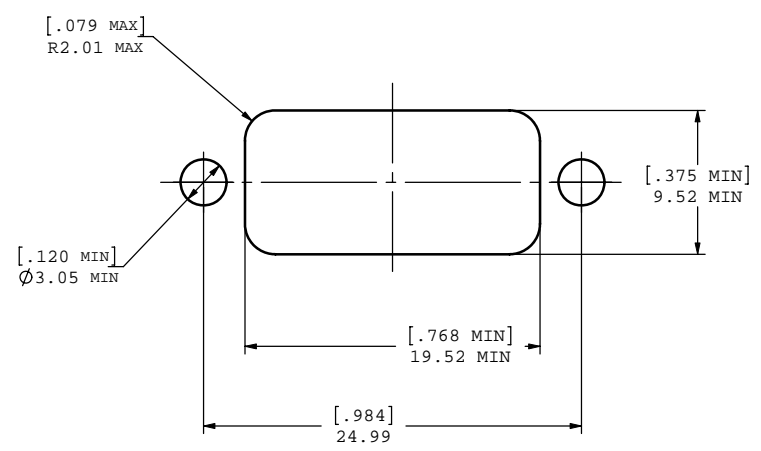

RECOMMENDED PANEL CUTOUT DIMENSIONS FOR REFERENCE ONLY

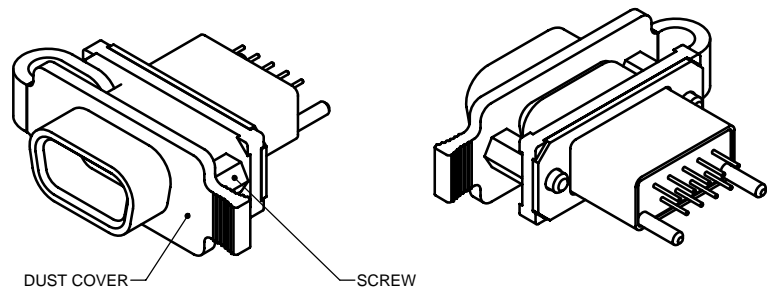

MDB-E09PA-760 IS SHOWN

FOR MORE INFORMATION ABOUT DUST COVER, SEE DRAWING P-MDB-227-093-205BP



UNLESS OTHERWISE SPECIFIED DIMENSIONS ARE IN MILLIMETER TOLERANCES ARE: DECIMALS ANGLES .XX ±.10 ± 1° .X ±.25	APPROVALS	DATE	Amphenol Canada Corp.	
	DRAWN S.SEMENOV	OCT06/06		
	DESIGNED S.SEMENOV	OCT06/06	TITLE	RUGGED 9 PIN, D-SUB CONNECTOR, VERTICAL MOUNT
	CHECKED		SIZE	
MATERIAL AND FINISH	QA APP'D		DWG. NO.	P-MDB-E09PA-76X
REF.	IE APP'D		SCALE	3:1
CODE IDENT. NO.	DWG APP'D A.GREEN	OCT06/06	PROJECT	MDB
			SHEET	2 OF 2

DO NOT SCALE DRAWING
THIS DOCUMENT CONTAINS PROPRIETARY INFORMATION AND SUCH INFORMATION MAY NOT BE DISCLOSED TO OTHERS FOR ANY PURPOSE OR USED FOR MANUFACTURING PURPOSES WITHOUT PERMISSION FROM AMPHENOL CANADA CORP.