

REVISIONS			
REV	DESCRIPTION, ECN, EAR NO.	DATE	APP'D
D	PRODUCT DRAWING (EAR 13700/13725)	JUN04/10	K.L

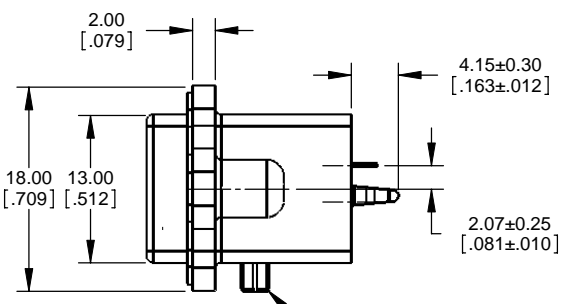
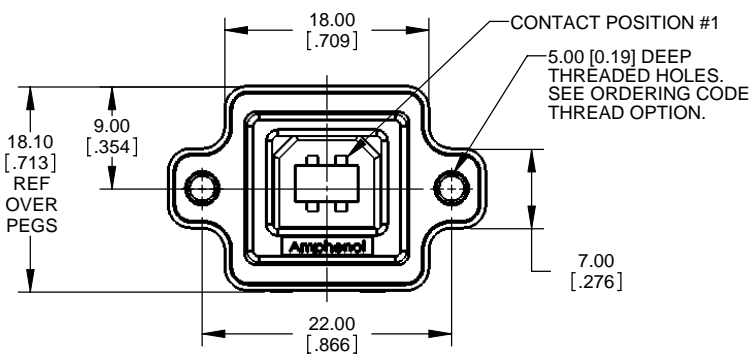

ORDERING CODE: M U S B - D 5 1 1 - X X

SERIES, RUGGED USB

USB SERIES 'B' RECEPTACLE, VERTICAL, PCB TAIL

THREAD OPTION
 0=#4-40 UNC THREAD
 N=M3 x 0.5 THREAD

DUST COVER OPTION
 0=NO DUST COVER SUPPLIED
 1=WITH GREY DUST COVER SUPPLIED
 5=WITH BLACK DUST COVER SUPPLIED

PART MAY BE SUPPLIED WITH OR WITHOUT SIDE PEGS

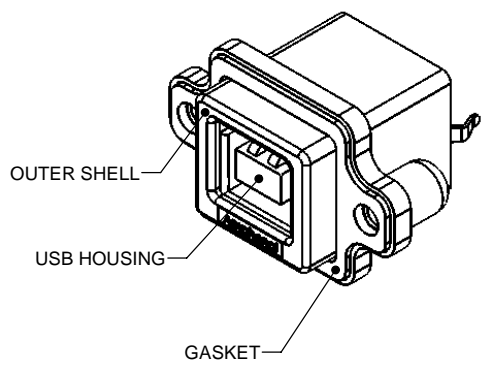
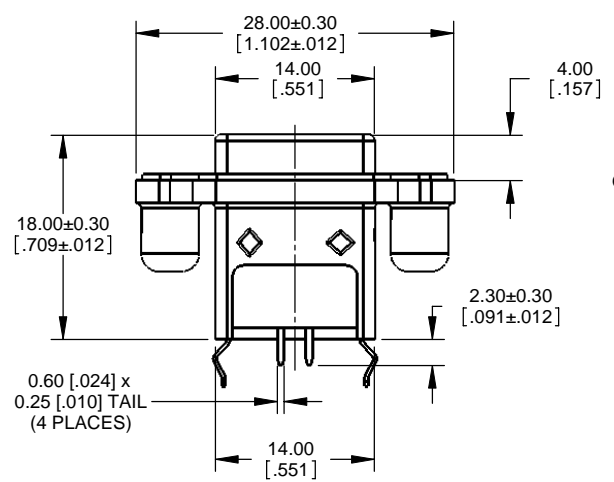

NOTES:

- MATERIAL:
 ALL MATERIALS ARE RoHS COMPLIANT PER EU DIRECTIVE 2002/95/EC AND AMENDMENTS
 - SHELL - DIECAST ZINC, NICKEL PLATED
 - CONTACTS - COPPER ALLOY WITH 30 MICROINCHES (0.76 MICRONS) GOLD OVER 50 MICROINCHES (1.27 MICRONS) MINIMUM NICKEL ON THE MATING AREA AND TIN ON THE CONTACT TAILS.
 - INSERTS - ENGINEERING THERMOPLASTIC, UL FLAMMABILITY RATING 94V-0, COLOUR: WHITE
 - GASKET - SILICONE RUBBER
 - DUST COVER - SILICONE RUBBER WITH NICKEL PLATED, COPPER ALLOY BUSHING
- ENVIRONMENTAL PERFORMANCE PER IEC 60529 CODE IP67 FOR SEAL BETWEEN MATING AREA AND PCB SIDE OF CONNECTOR. GASKET PROVIDES SEAL TO INSIDE FACE OF PANEL.
- CURRENT RATING: 1.5 AMPERES
- CONTACT RESISTANCE: 30 MILLIOHMS MAXIMUM
- OPERATING TEMPERATURE: -40C TO +105C
- DUST COVERS MAY BE ORDERED SEPARATELY. SPECIFY
 - MUSB-2D11-004BP FOR GREY DUST COVER
 - MUSB-2D11-014BP FOR BLACK DUST COVER
 SEE SHEET 2 FOR APPLICATION VIEW

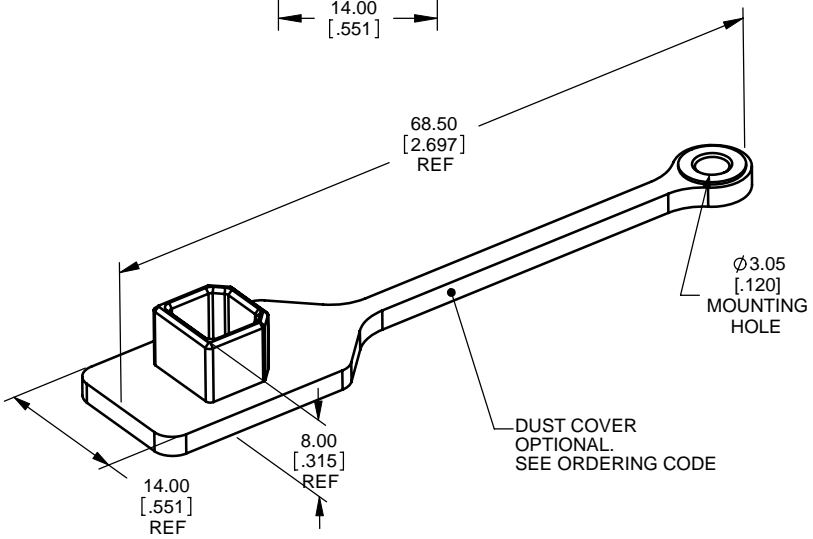

UNLESS SPECIFIED OTHERWISE	DRAWN	A.DODDS	JUL19/07
PRIMARY UNITS MILLIMETERS	CHECKED	K.LAMBIE	JUL20/07
SECONDARY MILLIMETERS	M.E. APP'D		
REFERENCE IN PARENTHESES	Q.A. APP'D		
GENERAL TOLERANCES	DWG APPR.		
1 DECIMAL PLACE	ENG. REL. NO.	EAR 13139	
2 DECIMAL PLACES ±0.20	REF.		
3 DECIMAL PLACES	THIRD ANGLE PROJECTION		
ANGULAR DEGREES	DO NOT SCALE DRAWING		

Amphenol Canada Corp.

MUSB SERIES RUGGED USB RECEPTACLE, SERIES 'B' INTERFACE, VERTICAL PCB MOUNT, RoHS COMPLIANT

DWG. NO. P-MUSB-D511-XX REV D

CODE ID NO. 03554 DWG SIZE: C SCALE: 3:1 SHEET 1 OF 2

REVISIONS			
REV	DESCRIPTION, ECN, EAR NO.	DATE	APP'D
D	PRODUCT DRAWING (EAR 13700/13725)	JUN04/10	KL

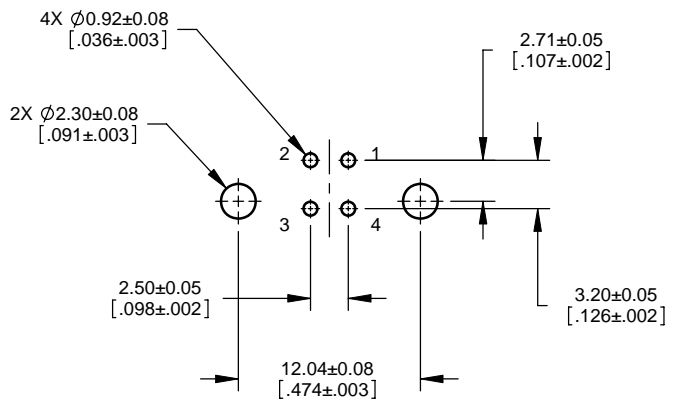

RECOMMENDED P.C.B. LAYOUT
(COMPONENT SIDE OF BOARD)

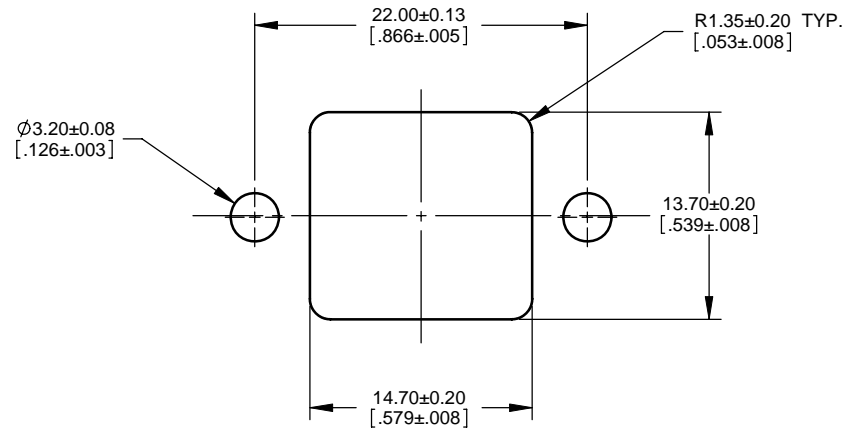

RECOMMENDED PANEL CUTOUT

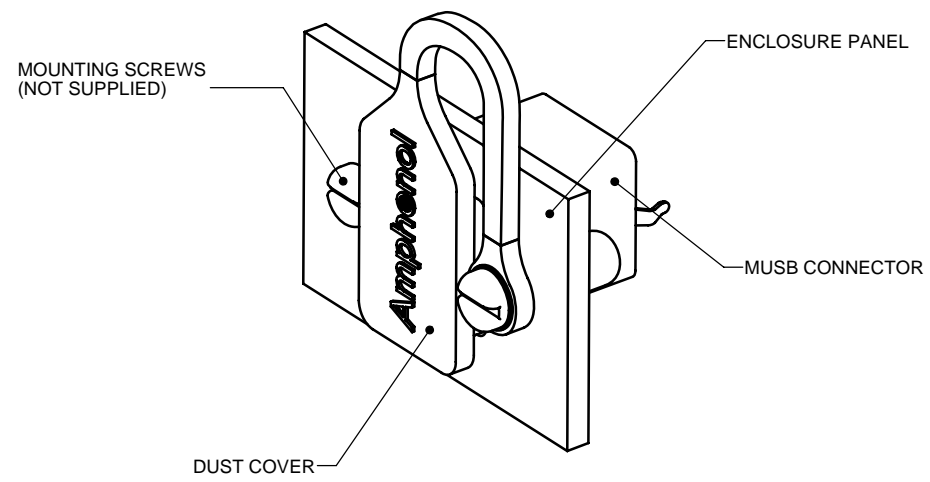

DUST COVER APPLICATION
SCALE 3:1



UNLESS SPECIFIED OTHERWISE	DRAWN	A.DODDS	JUL19/07
PRIMARY UNITS MILLIMETERS	CHECKED	K.LAMBIE	JUL20/07
SECONDARY INCHES	M.E. APP'D		
REFERENCE IN PARENTHESES	Q.A. APP'D		
GENERAL TOLERANCES	DWG APPR.		
1 DECIMAL PLACE	ENG. REL. NO.	EAR 13139	
2 DECIMAL PLACES	REF.		
3 DECIMAL PLACES	THIRD ANGLE PROJECTION		
ANGULAR DEGREES	DO NOT SCALE DRAWING		

Amphenol Canada Corp.

MUSB SERIES RUGGED USB RECEPTACLE, SERIES 'B' INTERFACE, VERTICAL PCB MOUNT, RoHS COMPLIANT

DWG. NO. **P-MUSB-D511-XX** REV **D**

CODE ID NO. 03554 DWG SIZE: C SCALE: 4:1 SHEET 2 OF 2