

REVISIONS				
REV.	ECN, ERN NO.	DATE	REV BY	APPRD.
A	PROPOSAL DRAWING	OCT25/06		L.Chan
B	PROPOSAL DRAWING	JUN08/12		L.Chan
C	PROPOSAL DRAWING	JUN11/12		L.Chan
D	FIX LED SCHEMATIC	JAN07/13		L.Chan

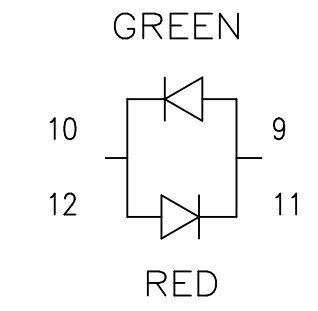

BI-COLOR LED DETAIL
 (YELLOW/GREEN, RED/YELLOW AND GREEN/ORANGE LED'S ARE ALSO AVAILABLE)

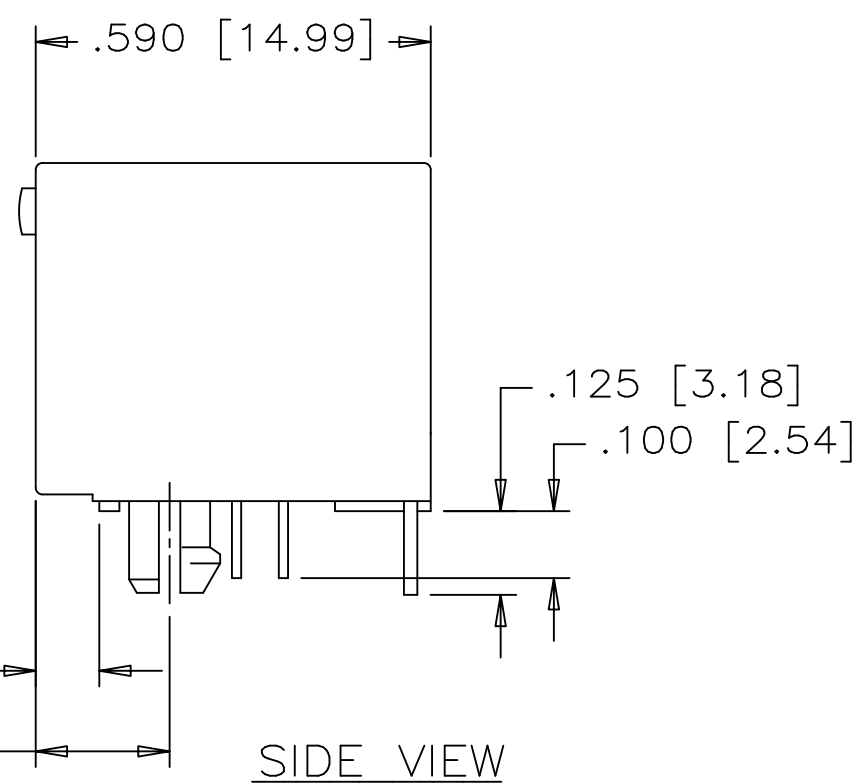
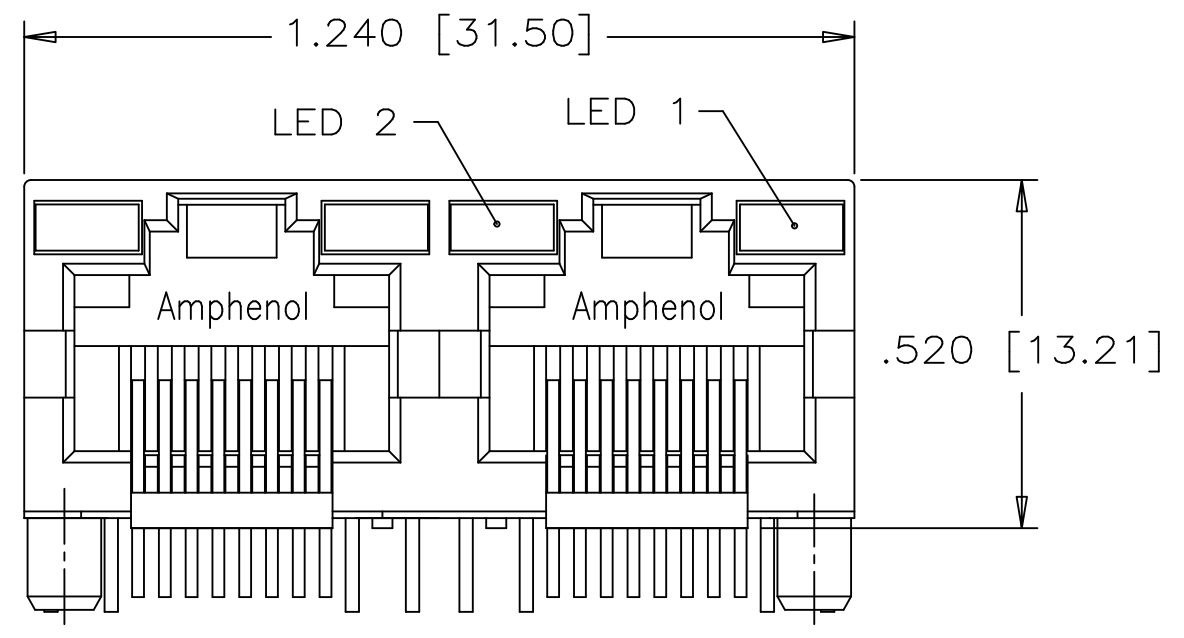
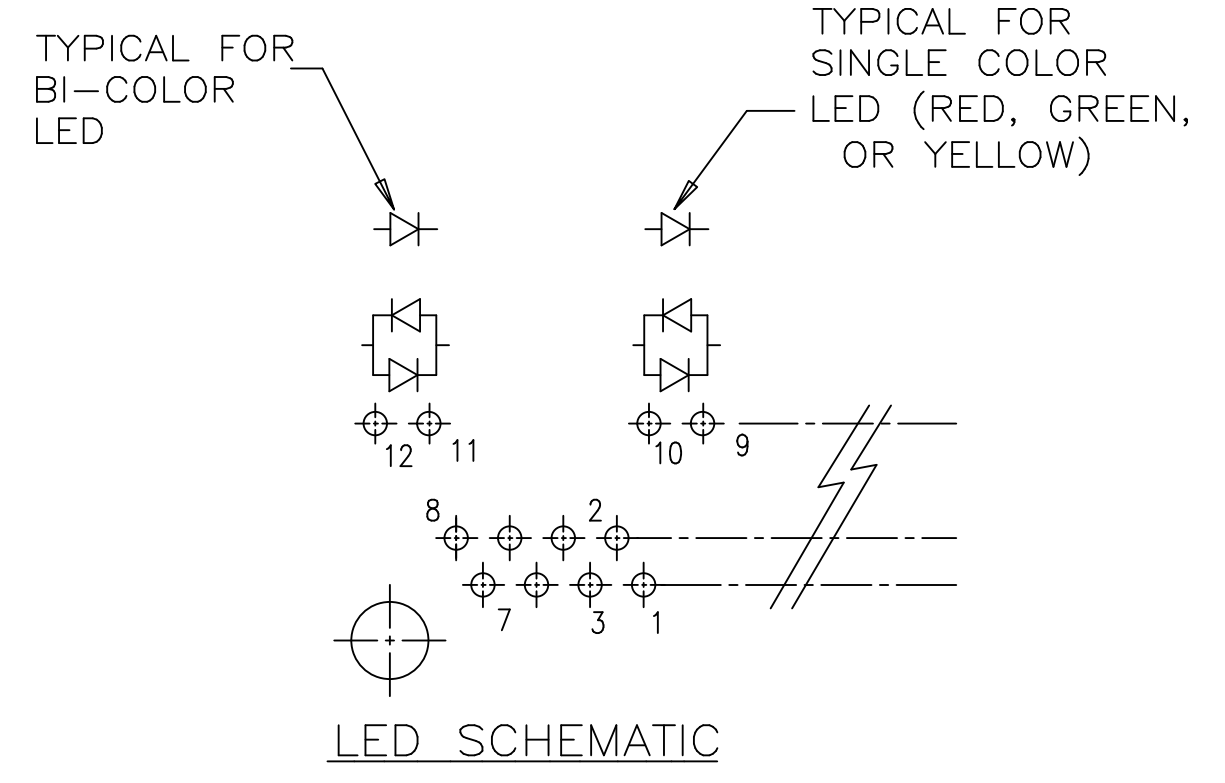
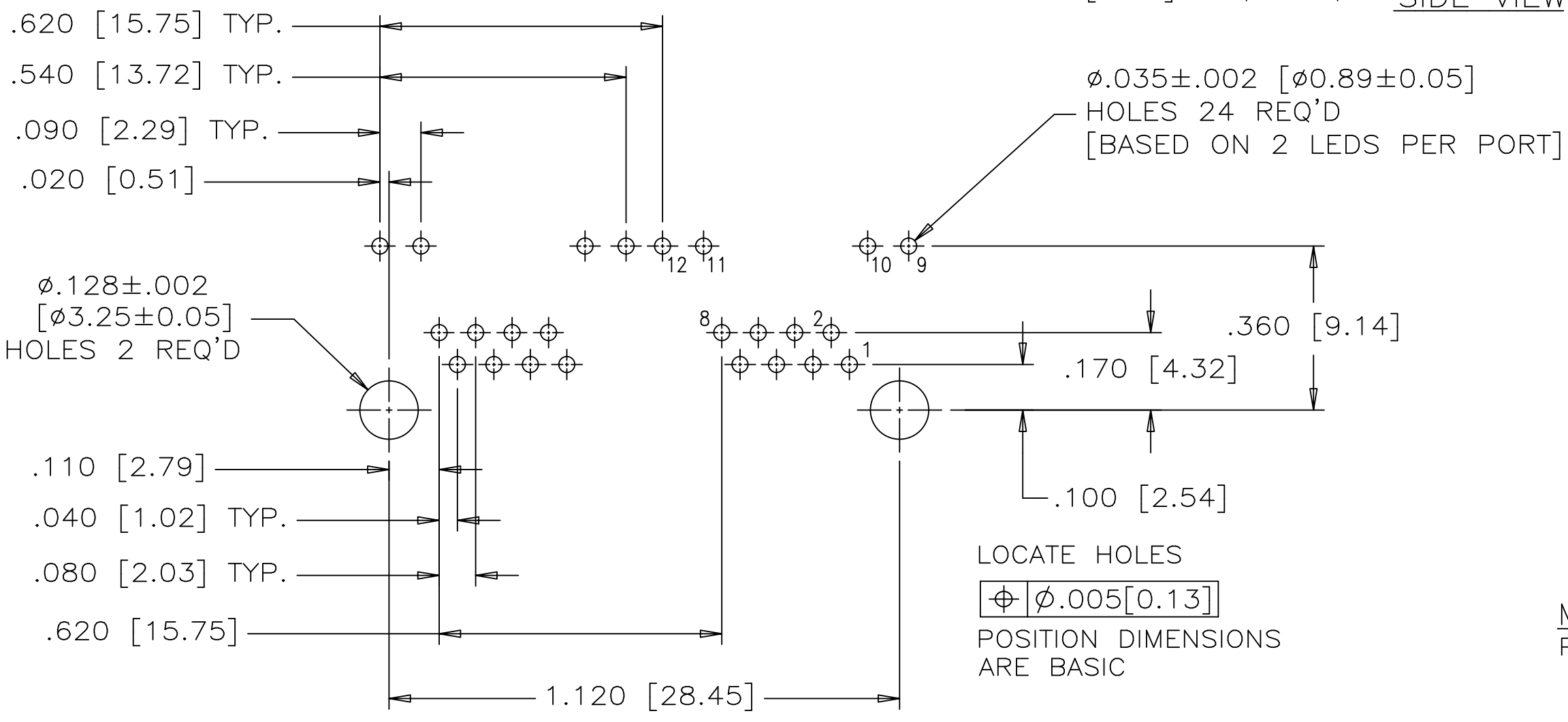

MATERIALS:
 PLASTIC HOUSING: ENGINEERING THERMOPLASTIC
 FLAMMABILITY RATING UL 94V-0

CONTACTS:
 PHOSPHOR BRONZE
 PLATING: 50 μ" [1.27 MICRONS]
 MIN. GOLD ON MATING SURFACES.
 50 μ" [1.27 MICRONS]
 MIN. NICKEL UNDERPLATE
 100 μ" [2.54 MICRONS]
 MIN. MATTE TIN ON CONTACT TAILS.

PART NUMBER: RJHSE-508X-02
 REFER TO AMPHENOL CATALOGUE FOR LED COLOUR OPTIONS

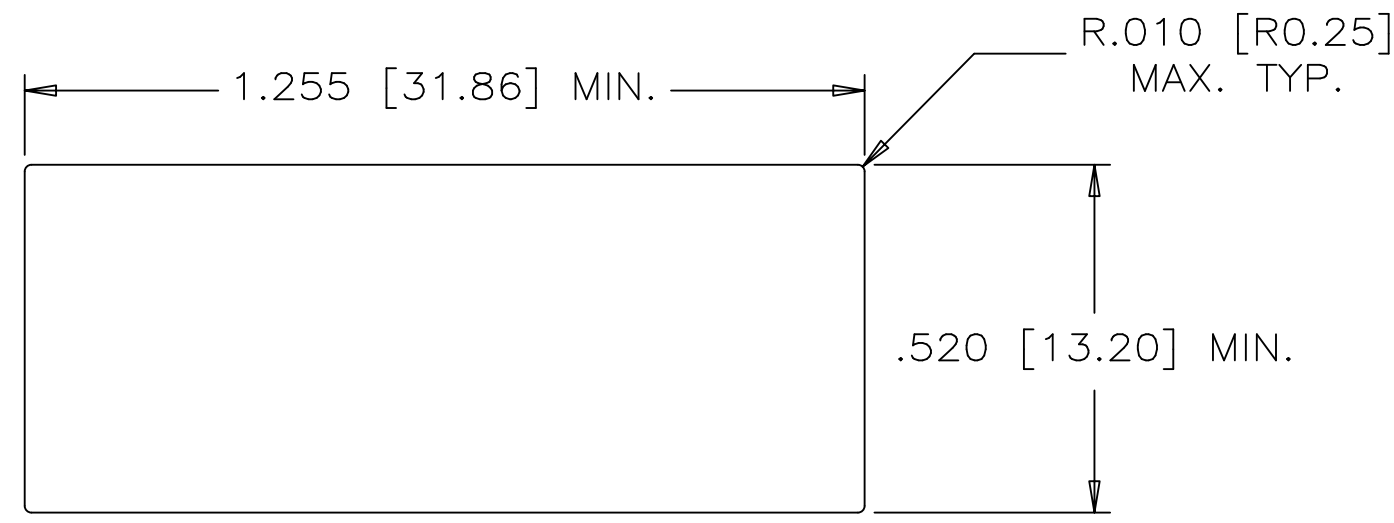

DRAWN	J. Wang	DATE	00/02/14	Amphenol Canada Corp.	
DESIGNED					
CHECKED	Chigow Xu	DATE	00/05/31	TITLE	
I. E. APPRD.				2 PORT HIGH SPEED MODULAR JACK, 8 POSITION, 8 CONTACTS, WITH LEDS, WITHOUT SHIELD	
Q. A. APPRD.				DWG	DRAWING NO.
DWG. APPRD.				P-RJHSE-508X-02	
ENG. REL. NO.				REV.	D
REF.				SCALE	
DIMENSIONS ARE IN	INCHES [mm]	CODE ID. NO.	03554	WT.	SURF.
				SHEET 1 OF 1	

THIS DOCUMENT CONTAINS PROPRIETARY INFORMATION AND SUCH INFORMATION MAY NOT BE DISCLOSED TO OTHERS FOR ANY PURPOSE OR USED FOR MANUFACTURING PURPOSES WITHOUT WRITTEN PERMISSION FROM AMPHENOL CANADA CORP.