

REVISIONS				
SYM	ZONE	ECN, ERN NO.	DATE	APPRD.
F		PROPOSAL	SEP 13/12	A.G.
G		ADD DISTANCE BETWEEN PANEL AND CONNECTOR	MAY 06/13	L.CHAN
H		ADD OPERATING TEMPERATURE.	MAY 10/13	L.CHAN

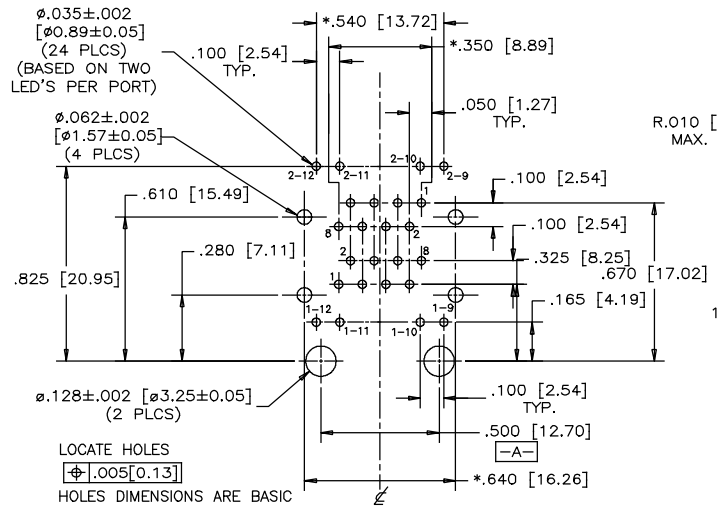

RECOMMENDED P.C.B. LAYOUT
(COMPONENT SIDE OF BOARD)

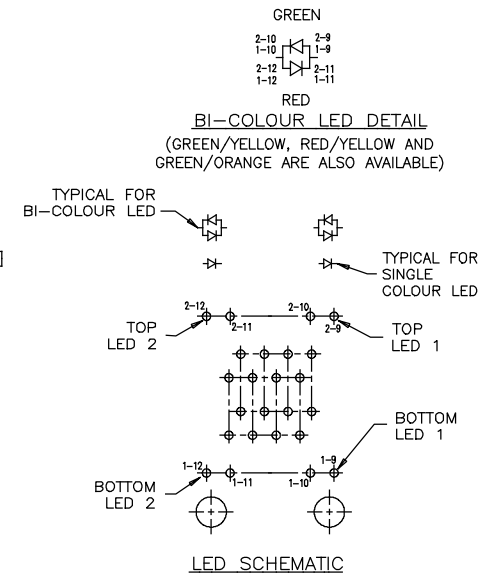
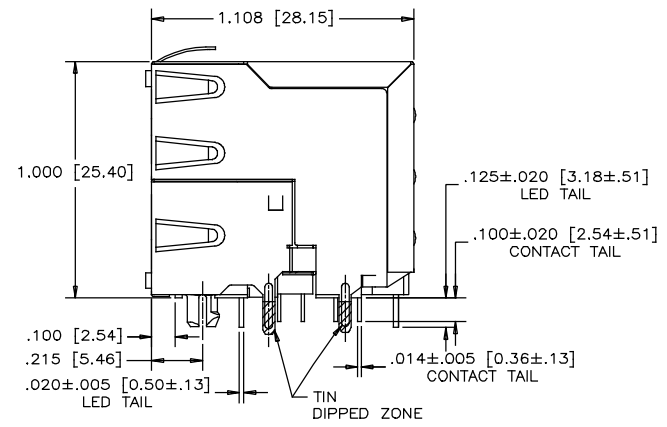
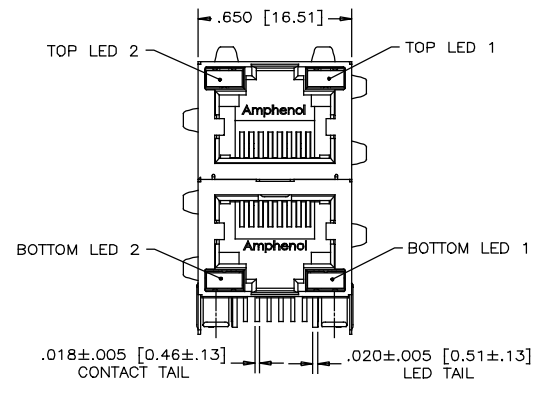
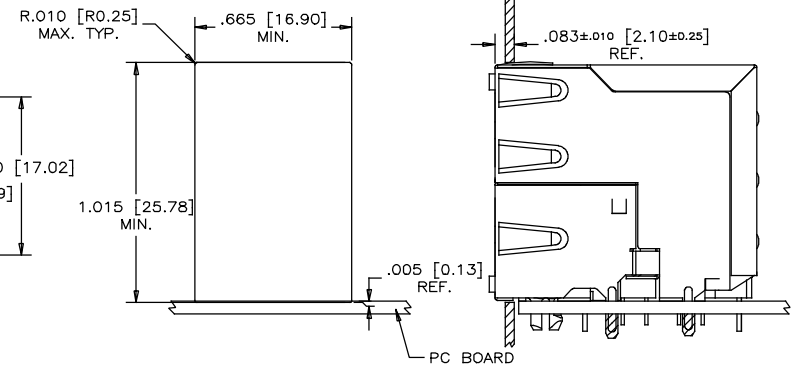

RECOMMENDED PANEL CUTOUT

- MATERIALS:**
- CONTACTS:** PHOSPHOR BRONZE, SELECTIVELY PLATED WITH 50 MICROINCHES MIN. GOLD ON MATING AREAS. 50 MICROINCHES MIN. NICKEL OVERALL. 100 MICROINCHES MIN. MATTE TIN OR GOLD FLASH ON TAILS.
- HOUSING:** HIGH TEMPERATURE THERMOPLASTIC FLAMMABILITY RATING UL 94V-0, BLACK
- SHIELD:** COPPER ALLOY. PLATING: NICKEL WITH TIN DIPPED PCB TAILS.
- RECOMMENDED SOLDERING TEMPERATURE:** WAVE SOLDERING AT 260°C MAXIMUM FOR 5 SEC MAXIMUM
- DIELECTRIC WITHSTANDING VOLTAGE:** 1000 VAC PEAK, CONTACT TO CONTACT 1500 VAC PEAK, CONTACT TO SHIELD
- OPERATING TEMPERATURE:** -55 °C to +85 °C

AMPHENOL PART NO.: RJSAE-538X-02X
REFER TO LED OPTIONS DRAWING FOR ORDERING CODES

DIMENSIONS MARKED WITH * ARE SYMMETRICAL ABOUT CENTER LINE AS DEFINED BY DATUM -A-

THIS DOCUMENT CONTAINS PROPRIETARY INFORMATION AND SUCH INFORMATION MAY NOT BE DISCLOSED TO OTHERS FOR ANY PURPOSE OR USED FOR MANUFACTURING PURPOSES WITHOUT WRITTEN PERMISSION FROM AMPHENOL CANADA CORP.

DRAWN PAULW	DATE APR19/06
DESIGNED	
CHECKED CHIGOW	APR19/06
I. E. APPRD.	
Q. A. APPRD.	
DWG. APPRD.	
ENG. REL NO.	
REF. EAR RJ12064	
DIMENSIONS ARE IN INCHES [mm]	CODE ID. NO. 03554

Amphenol Canada Corp.

TITLE
RJSAE SERIES 2x1 STACKABLE MODULAR JACK, 8 CONTACTS & 2 LED PER PORT, SHIELDED WITH SIDE GROUND TABS (2 PIECE CONSTRUCTION) - RoHS COMPLIANT

DWG. DRAWING NO. P-RJSAE-538X-02X REV. H

SCALE WT. _____ SURF. _____ SHEET 1 OF 1

REVISIONS				
SYM	ZONE	ECN, ERN NO.	DATE	APPRD.
H		PROPOSAL	JUL04/12	L.CHAN
J		UPDATE ROHS STAMP	JAN21/13	L.CHAN

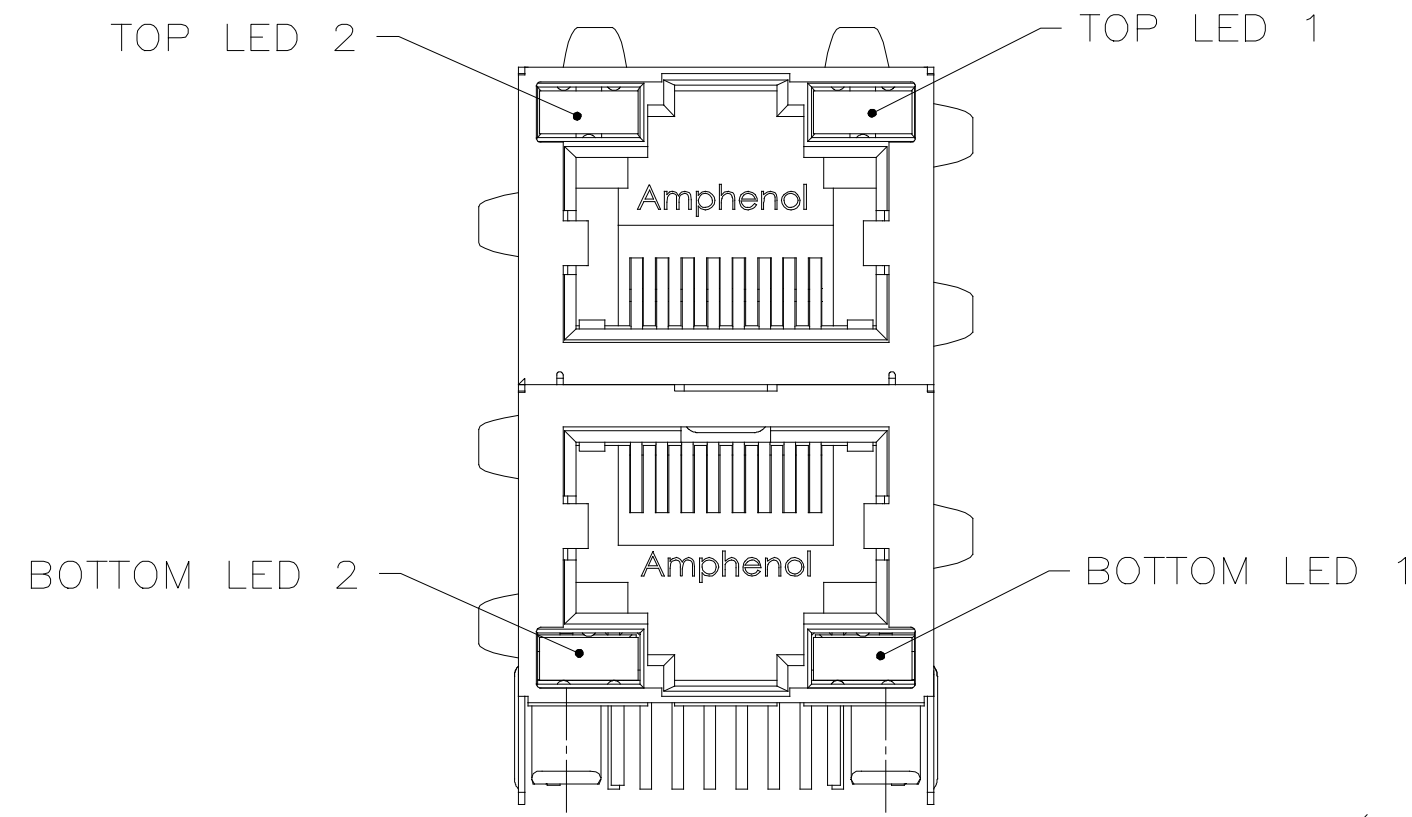

LED SPECIFICATIONS:
 FORWARD VOLTAGE: 2.1 VOLTS TYP.
 REVERSE VOLTAGE: 5.0 VOLTS MIN.
 LUMINOUS INTENSITY: 0.5 mCd MIN.
 (AT If=2mA)
 STORAGE TEMPERATURE: -40° TO 85° C
 PLATING ON TAILS: TIN OR TIN/COPPER ALLOY OVER SILVER



EXAMPLE:1

PART NUMBER RJS AE-***X-**
 SEE NOTE 2 (pointing to first three asterisks)
 SEE NOTE 2 (pointing to last two asterisks)
 LED COLOR CODE

EXAMPLE:2

PART NUMBER RJS AE-***U-**-XX
 SEE NOTE 2 (pointing to first three asterisks)
 SEE NOTE 2 (pointing to last two asterisks)
 SPECIAL CODE FOR TOP & BOTTOM LEDS CONFIGURATION
 BOTTOM ASSY LED (SAME AS STD CODE)
 TOP ASSY LED (SAME AS STD CODE)

PRIMARY COLOR FOR BI-COLOR LEDS IN STANDARD ANODE/CATHODE CONFIGURATION IS:
 RED-GREEN= RED
 RED-YELLOW= RED
 GREEN-YELLOW= GREEN
 GREEN-ORANGE= GREEN

CODE	LED 2 (LEFT)	LED 1 (RIGHT)	CODE	LED 2 (LEFT)	LED 1 (RIGHT)	CODE	LED 2 (LEFT)	LED 1 (RIGHT)
0	BLOCKED	BLOCKED	9	GREEN	BLOCKED	J	BiC RD/GR	YELLOW
1	YELLOW	GREEN	A	BiC GR/YE	BiC GR/YE	K	YELLOW	BiC GR/OR
2	BLOCKED	GREEN	B	BiC RD/GR	BiC RD/GR	L	BiC GR/YE	RED
3	YELLOW	BLOCKED	C	BiC RD/GR	BiC GR/YE	M	RED	YELLOW
4	GREEN	YELLOW	D	GREEN	BiC GR/YE	N	BiC GR/RD	BiC GR/YE
5	GREEN	GREEN	E	YELLOW	BiC GR/YE	P	GREEN	BiC RD/GR
6	YELLOW	YELLOW	F	BiC GR/YE	YELLOW	R	BiC GR/OR	GREEN
7	RED	GREEN	G	BiC GR/OR	BiC GR/OR	T	RED	RED
8	GREEN	RED	H	BiC GR/YE	GREEN	V	BiC RD/GR	GREEN
			W			W	ADDITIONAL OPTIONS	
			U			U	SPECIAL CODE FOR TOP & BOTTOM LEDS CONFIGURATION	

LEGEND

BiC=BI-COLOR LED
 LOWC=LOW CURRENT LED
 YE=YELLOW
 GR=GREEN
 RD=RED
 OR=ORANGE

EXAMPLE:3

PART NUMBER RJS AE-***W-**X
 SEE NOTE 2 (pointing to first three asterisks)
 SEE NOTE 2 (pointing to last two asterisks)
 ADDITIONAL LED COLOR CODE
 DENOTES ADDITIONAL LED OPTIONS TO BE USED

CODE	LED 2 (LEFT)	LED 1 (RIGHT)	CODE	LED 2 (LEFT)	LED 1 (RIGHT)	CODE	LED 2 (LEFT)	LED 1 (RIGHT)
0	DO NOT USE		5	BLOCKED	YELLOW	A	LOWC YE	LOWC YE
1	RED	BLOCKED	6	RED	BiC RD/GR	B	LOWC YE	LOWC GR
2	BiC GR/OR	YELLOW	7			C	LOWC GR	LOWC YE
3	YELLOW	RED	8	BiC RD/GR	BLOCKED	D	LOWC GR	LOWC GR
4	BLOCKED	RED	9	BiC GR/YE	BLOCKED	M	LOWC RD	LOWC YE
						N	GREEN	BiC GR/OR
						E	GREEN	ORANGE
						F	ORANGE	GREEN
						P	BiC RD/YE	GREEN
						R	BiC RD/YE	BiC RD/YE
						T	BiC GR/YE	BiC RD/GR

EXAMPLE:4

PART NUMBER RJS AE-***X-**XX*
 SEE NOTE 2 (pointing to first three asterisks)
 SEE NOTE 2 (pointing to last two asterisks)
 SEE NOTE 2 (pointing to final asterisk)
 LED COLOR CODE THE SAME AS EXAMPLE 1, 2, 3
 LED COLOR CODE THE SAME AS EXAMPLE 1, 2, 3
 SEE NOTE 2

NOTES:

- THE TWO DIGITS PRECEDING THE ADDITIONAL LED CODE MUST BE USED IN THE PART NUMBER, WHEN ORDERING ANY OF THE ADDITIONAL LED OPTIONS.
- '*' REPRESENT DIFFERENT OPTION OF CONNECTOR, DETAIL OPTION PLEASE SEE RELEVANT CONNECTOR DRAWING.

DRAWN PAUL WANG	DATE 05/07/22
DESIGNED	
CHECKED TERRY	05/07/22
I. E. APPRD.	
Q. A. APPRD.	
DWG. APPRD.	
ENG. REL. NO.	
REF.	
DIMENSIONS ARE IN INCHES [mm]	CODE ID. NO. 03554

Amphenol Canada Corp.	
TITLE LED OPTIONS FOR RJS AE, MULTI-PORT CONNECTORS - RoHS COMPLIANT	
DWG	DRAWING NO. P-RJS AE-LEDS
REV.	J
SCALE	WT. ----- SURF. ----- SHEET 1 OF 1

THIS DOCUMENT CONTAINS PROPRIETARY INFORMATION AND SUCH INFORMATION MAY NOT BE DISCLOSED TO OTHERS FOR ANY PURPOSE OR USED FOR MANUFACTURING PURPOSES WITHOUT WRITTEN PERMISSION FROM AMPHENOL CANADA CORP.